

TECHNICAL INFORMATION FOR NSM-PHONOGRAPH THE WIZARD OLD FASHION WIZARD

ES V-CD TECHNOLOGY

TO TECHNICAL INFORMATION, ASSY 176 352

NSM

Aktiengesellschaft
Saarlandstraße 240
6530 Bingen am Rhein

0

(TITLE PAGE)
Page 001 / 004

	1	2	3	4	
1	TECHNICAL INSTRUCTIONS	OPERATING INSTRUCTIONS	PROGRAMMING	CONTROL UNIT ES V	
6	CENTRAL UNIT ES V	7 OUTPUT STAGE	8 CD-CHANGER with PLAYER CDM-4	9 TITLE INDICATION II	5 DISPLAY/ KEY BOARD
11	REMOTE CONTROL	12	13 OUTPUT TRANSFORMER	14 TROUBLE SHOOTING	10 COIN and BILL ACCEPTOR
					15 ACCESSORIES

GENERAL

The modern technology of this new NSM phonograph ***THE WIZARD/OLD FASHION WIZARD*** with CD changer assures the highest functional reliability. A practical diagnostic system is available for maintenance and service.

In order to assure satisfactory operation at all times we recommend reading the technical descriptions carefully so that you are familiar with all service operations.

The following technical documents include:

- 1 The **"TECHNICAL INSTRUCTIONS"** with important information regarding set-up of the phonograph, technical data, location of the components, the "cabinet" parts list as well as the electrical plan and various wiring diagrams.
- 2 The **"OPERATING INSTRUCTIONS"** with explanations regarding play and settings as well as short instructions for statistics and service programs.
- 3 The **"STATISTICS AND SERVICE PROGRAMS"** as well as test programs and error displays. The convenient service programs help the user in maintenance and control and permit the transfer of bookkeeping and technical data into the new NSM recording device and the printer **"DATAPRINT"**.
- 4-13 The **"UNIT DESCRIPTIONS"** for control unit, display/keyboard, central unit, output stage, CD changer, title display, electronic coin mechanism and bill validator, remote control and output transformer with their functions and, where applicable, wiring diagram and parts list.
- 14 **"TROUBLE-SHOOTING CHART"**, a description of errors, error displays as well as flow chart to determine errors.
- 15 **"ACCESSORIES"**, information on genuine NSM accessories with instructions for installation and exercising options.

The information and illustrations contained in these technical documents are up to date at the time of publication.

SUBJECT TO TECHNICAL MODIFICATION WITHOUT OBLIGATION TO MODIFY EQUIPMENT ALREADY DELIVERED!

Copyright by
NSM Aktiengesellschaft, 6530 Bingen am Rheln 1, Germany

No reprint in full or part unless approved.

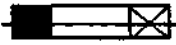
	"Caution: Replace With Same Typ Fuses" "Attention: Utiliser Un Fusible De Rechange de Meme Typ"
---	--

The CD-player with a laser scanning system used in this phonograph is a class I product (no risk, harmless laser system). The respective label is on the front of the changer behind the viewglass.



176 351, 176 352, 176 353
07/92

KONFORMITÄTSERKLÄRUNG

DECLARATION OF CONFORMITY

DECLARATION DE CONFORMITE

Wir NSM Aktiengesellschaft

We NSM Aktiengesellschaft

Nous NSM Aktiengesellschaft

Saarlandstr. 240
6530 BINGEN am RHEIN 1

Saarlandstr. 240
6530 BINGEN am RHEIN 1

Saarlandstr. 240
6530 BINGEN am RHEIN 1

erklären in alleiniger Verantwortung, daß das
Produkt

declare under our sole responsibility that the product

déclarons sous notre seule responsabilité que le
produit

NSM-Musikautomat

NSM-PHONOGRAPH

JUKE BOX-NSM

THE WIZARD / OLD FASHION WIZARD

THE WIZARD / OLD FASHION WIZARD

THE WIZARD / OLD FASHION WIZARD

auf das sich diese Erklärung bezieht, mit der/den
folgenden Norm(en) oder normativen Dokument(en)
übereinstimmt.

to which this declaration relates is in conformity with
the following standard(s) or other normative
document(s).

auquel se réfère cette déclaration est conforme à la
(aux) norme(s) ou autre(s) document(s) normatif(s).

EN 55 022; EN 60 555-2; EN 60 555-3

EN 55 022; EN 60 555-2; EN 60 555-3

EN 55 022; EN 60 555-2; 60 555-3

Gemäß den Bestimmungen der Richtlinie _____

following the provisions of Directive _____

conformément aux dispositions de Directive _____

89/336/EWG

89/336/EWG

89/336/EWG

Bingen am Rhein
15.06.92

Dr. Thomas Kühl

Bingen am Rhein
06-15-92

Dr. Thomas Kühl

Bingen am Rhein
15.06.92

Dr. Thomas Kühl

003

Note: This equipment has been tested and found to comply with the limits for a Class B digital device, pursuant to Part 15 of the FCC Rules. These limits are designed to provide reasonable protection against harmful interference in a residential installation. This equipment generates, uses and can radiate radio frequency energy and, if not installed and used in accordance with the instructions, may cause harmful interference to radio communications. However, there is no guarantee that interference will not occur in a particular installation. If this equipment does cause harmful interference to radio or television reception, which can be determined by turning the equipment off and on, the user is encouraged to try to correct the interference by one or more of the following measures:

- Reorient or relocate the receiving antenna.
- Increase the separation between the equipment and receiver.
- Connect the equipment into an outlet on a circuit different from that to which the receiver is connected.
- Consult the dealer or an experienced radio/TV technician for help.

CAUTION: These servicing instructions are for use by qualified personnel only. To avoid electric shock do not perform any servicing other than that contained in the Operating Instructions section 2 unless you are qualified to do so. Refer all servicing to qualified service personnel.

TECHNICAL INSTRUCTIONS
FOR NSM-PHONOGRAPHS
THE WIZARD
OLD FASHION WIZARD

ES V-CD TECHNOLOGY

TO TECHNICAL INFORMATION, ASSY -176 352-

NSM

Aktiengesellschaft
Saarlandstraße 240
6530 Bingen am Rhein

1

Page 101-140 / 141

INDEX

- 1 PLEASE READ INSTRUCTIONS**
 - 1.1 Transport damages**
 - 1.2 Keys**
 - 1.3 Use NSM mounting bracket**
 - 1.4 Observe when using an upright stand**
 - 1.5 Transport devices**
 - 1.6 Power connection**
 - 1.7 Title strips and CD's**

- 2 LAYOUT OF UNITS**
 - 2.1 Display / Keyboard**

- 3 SPECIFICATIONS**
 - 3.1 Electrical data**
 - 3.2 Musik power**
 - 3.3 Fuses**
 - 3.4 Lighting**
 - 3.5 Credit / Cash input**
 - 3.6 Keyboard**
 - 3.7 Displays**
 - 3.8 CD changer**
 - 3.9 Loudspeakers**
 - 3.10 Special features**
 - 3.11 Dimensions**

- 4 LOUDSPEAKER CONNECTION**
 - 4.1 Output transformer**

- 5 SPARE PARTS LIST "CABINET"**

- 6 OPERATING SCHEME**

1 PLEASE READ INSTRUCTIONS

Storage and operation of this device is allowed in dry rooms only.

1.1 Transport Damages

If external damage due to transport is noticed, this should at once be recorded on the delivery slip and endorsed by the person making the delivery.

The manufacturer is not liable for damages during transport!

1.2 Keys

One cabinet key is taped to the front glass. The other keys are in the cashbox. To open the cabinet unlock on the right side and open the door.

1.3 Use NSM Mounting Bracket (Part-No. 040 739)

So that the coin mechanism can function correctly, mount the phonograph horizontally and vertically correct. Therefore, we recommend the practical NSM mounting bracket.

Take care to mount the bracket untwisted since the rear of the cabinet can otherwise be twisted.

To secure the phonograph to the bracket, hexagonal screw M 10x12 -from the accessory bag- is to be used.

Plug in connection cable before mounting (see 1.6 "Power Connection").

TECHNICAL INSTRUCTIONS!

for Mounting of the machine on the wall

Secure mounting of the machine is very important since besides the danger of severely damaging the machine, the operator is responsible for all damages caused by an incorrectly mounted wallbox; when choosing the fastening material, take into account the machine's weight of 83 kg.

We recommend dowel pins in sufficient quantities.

The screws should be at least 6 mm in diameter!

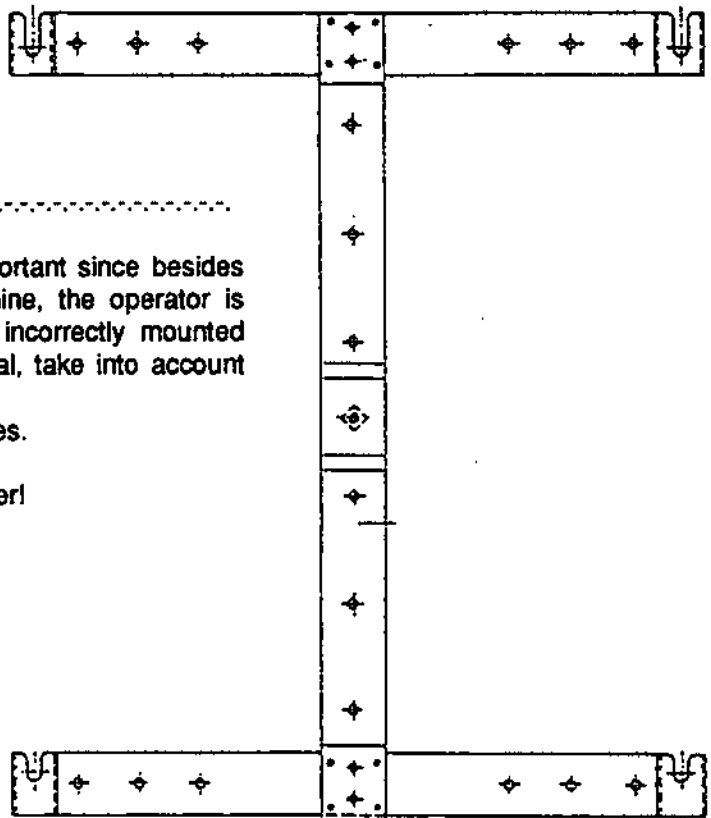

Instance: **Plastic - Wallplug**

First a few tips:

- The maximum bearing capacity of nylon expansion plugs may only be achieved with the greatest possible screw diameters and with screws exceeding the plug point by the screw diameter again.
- Please ensure that with fixings in hollow brick and hollow blocks that the expansion zone of the plug is completely anchored in at least one stone web.
- Determination of minimum screw length

- 1xd (d=nominal diameter of screw)
- + Plug length
- + Thickness of plaster and/or insulating material
- + Thickness of mounting bracket 3 mm

= Min. screw length

If you observe these tips you will have created the prerequisite for secure fixings.

Pull-out values in kN*. Determined in each case with the largest screw diameter (steel screw) and with flush fixing of the plug in the load-bearing anchorage base.

Allowance must be made for an appropriate safety factor.

Type-Wallplug	Pull-out values (kN)			
	S5	S6	S8	S10
Wood screws dia in mm			6	
Concrete B25			4,5	
Aerated concrete GB 3,3			1,2	
Aerated concrete G 4			1,3	
Solid brick Mz20			4,1	
Perforated brick Hlz20			3,0	

*KN = Kilonewton (1KN = 100 kp)

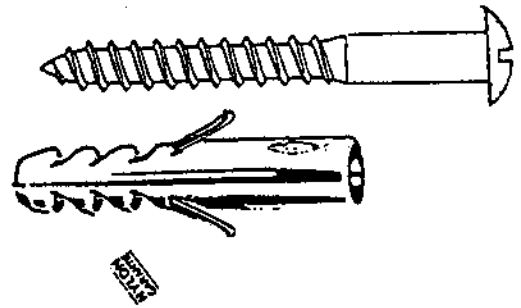

Wichtig:
mind. 1 x Schrauben-Ø

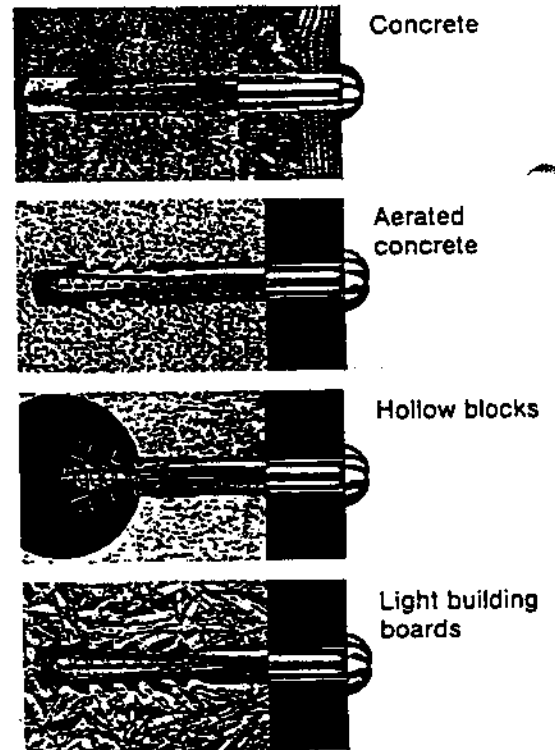
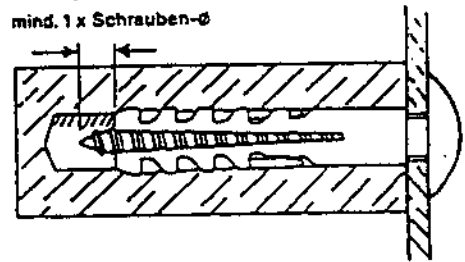

The following points must be observed when drilling, irrespective of the material:

1. Drill hole geometry

The exact drill hole geometry dictates the load-bearing capacity of a plug. Therefore always drill at right-angles and do not change direction during drilling. This is especially to be observed in the case of soft materials.

2. Drill process

The following drilling methods are possible depending on the type of drilling machine:

- Rotary - without impact
- Impact drill-many impacts with a low amount of impact energy. Fast rotation
- Hammer drill - few impacts with a high amount of impact energy. Slow rotation.

The material determines the drill process:

- Solid materials of dense structure: Impact and hammer drilling.
- Hollow brick, materials of low strength and aerated concrete: Only rotary so that the hole does not become too big and in hollow brick the webs do not break out.

Never forget to remove the dust from the drill hole after drilling. Only then is the plug secure.

Pull - Out Values - Safety Factors:

The pull-out values (breaking loads) given in this catalog are mean failure loads determined in at least 5 tests in uncracked building material. Failure criteria may be: failure of building material, breaking of bolt, loosening of anchor, breaking of anchor.

The maximum working load is calculated by dividing the pull-out value (breaking load) by the safety factor.

As a safety factor we recommend: for nylon wallplugs $\sqrt{\geq 7}$.

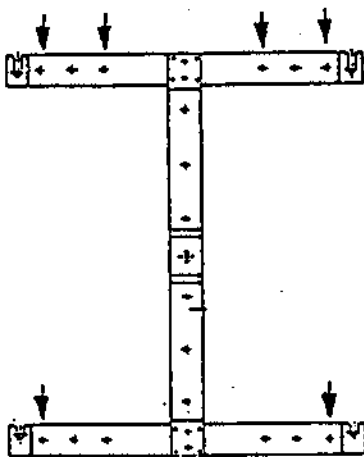

Example: In aerated concrete GB 3,3 the pull-out value for 8 plugs with 6 diameter screws is 1,2 KN. Divided by safety factor 7 equals 0,17 KN = 17 Kp for 1 screw. The weight of the machine is 83 kg; therefore, at least 83 kg / 17 Kp = 5 screws are necessary. For safety and symmetry reasons 6 screws are to be used (see sketch).

When fixing the machine to the wall, make sure the vent is not hindered in its function. When using the mounting bracket, there is normally enough distance between cabinet and wall for air circulation. Plush wall hangings decrease this distance; in that case the bracket has to be fastened to a flat board. Do not mount machine above heaters!

1.4 Observe When Using an Upright Stand

If the machine is mounted on a stand, it must be made sure that it cannot fall over. Therefore, it is recommended to use sandbags to weigh down the stand. With approx. 15° angle the open machine should not tip over!

1.5 Transport Devices

Before operating the phonograph all devices for safety and protection during transport have to be removed.

Prior to any further transit the safety and protection devices have to be replaced.

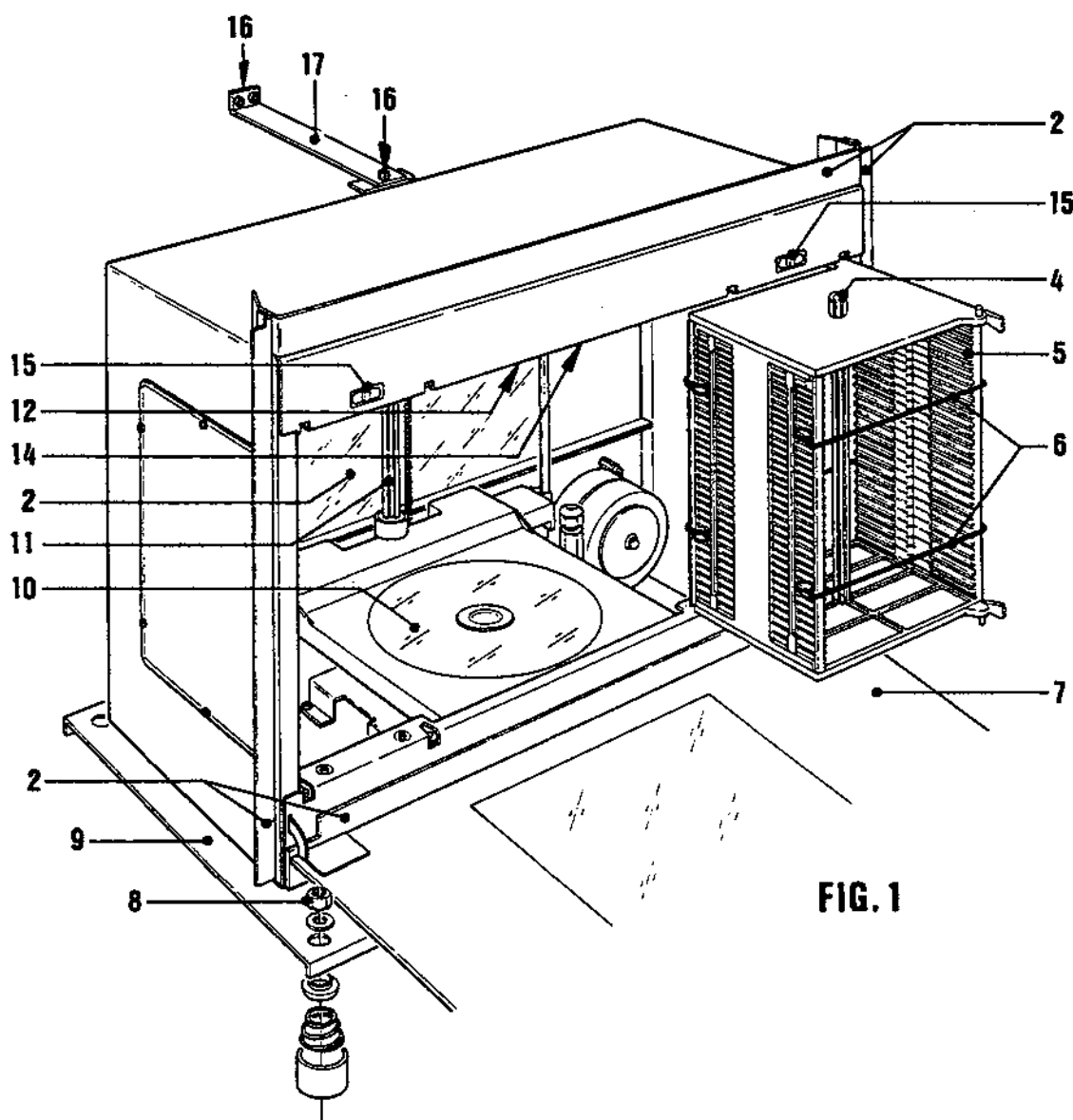

FIG. 1

- If the PCB holding plate (FIG. 1-12) is to be flipped down, the fastening screw is to be removed.
- Push the bar locker (FIG. 1-15) to the center and swing out left and right magazine (FIG. 1-5).
- Remove slotted plastic pipe from the lift axle (FIG. 1-11).

Keep transport devices in a suitable location in cabinet for later transport!

Information for transport of CD changer:

When exchanging the changer, it may only be transported in the original packaging!

- Remove magazine, push the proper button (FIG. 1-15) outwards and remove the unit. Inserted CD's can be kept from falling out when the plastic pipe from the lift axle as well as a second one from the enclosed package is put through the opening (FIG. 1-4) and all CD's of the magazines.
- Remove design parts: Take out front glass (FIG. 1-7).
- Put in safety and protection devices in proper sequence.

1.6 Power Connection

The label on the power cord shows the voltage setting by the factory.

For other voltages set voltage required on transformers.

Put in power line into 3-pole socket on rear of cabinet.

Green-yellow of the three-wire power cord must be connected to the ground according to the international safety code.

Check main voltage before connecting!

After plugging in the phonograph turn on the switch -located under right side of cabinet- fluorescent lights should now light up.

1.7 Insert title strips and CD's

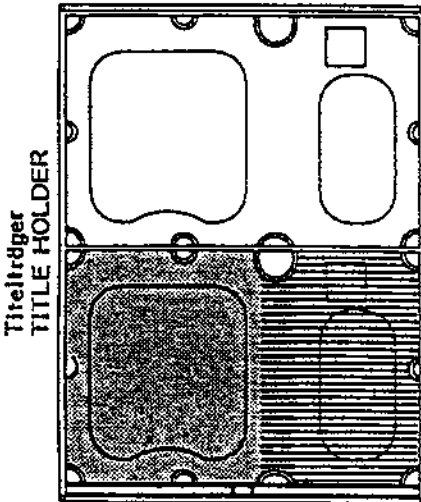
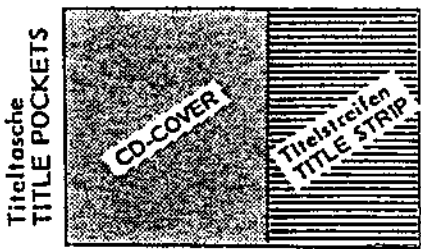

PLEASE OBSERVE!

Equipping of black title holders should be done as follows:

Remove title pockets from accessory pack, insert CD covers on the left side and written title strips on the right side in the title pocket - thicker foil side of title pocket to the outside - and insert then in black title holder.

If the covers are bigger than 120x120 mm, they need to cut to size - please use only title cover.

The title program displays are moved by pressing the <-- key or the --> key on the outside of the machine or the "TL" or "TR" key on the title display PCB.

- TITLE STRIP Part-No. 219 185
- TITLE COVER Part-No. 212 509

In case of dislocation of title holders due to rough Transportation, please refer to section 9, paragraph 1.4 "Jammed or dislocated title holders".

CD-Changer: In order to avoid movement of the lift (Attract mode) the cabinet switch has to be pulled out. Now the device is in service mode. In addition, the CD will be returned when it remains on the player after the last track (see also: CD-Changer "Return Holder").

Push button (FIG 1-15) to the center, swing out the magazine, pull out tray and load with CD's. Observe the sequence of the magazine and title strip numbers.

Take care to push in the CD trays until they rest in center and do not hinder the lift.

Note: To take out the magazines push the button (FIG. 1-15) to the outside; take out magazines one after the other!

The CD's can be protected against falling out, when transporting loaded magazines, by putting the plastic pipes (FIG. 1-4) through the magazines and all loaded CD's.

Use the enclosed 4 clamps as transportation fixture for the CD-magazines.

2 LAYOUT OF UNITS

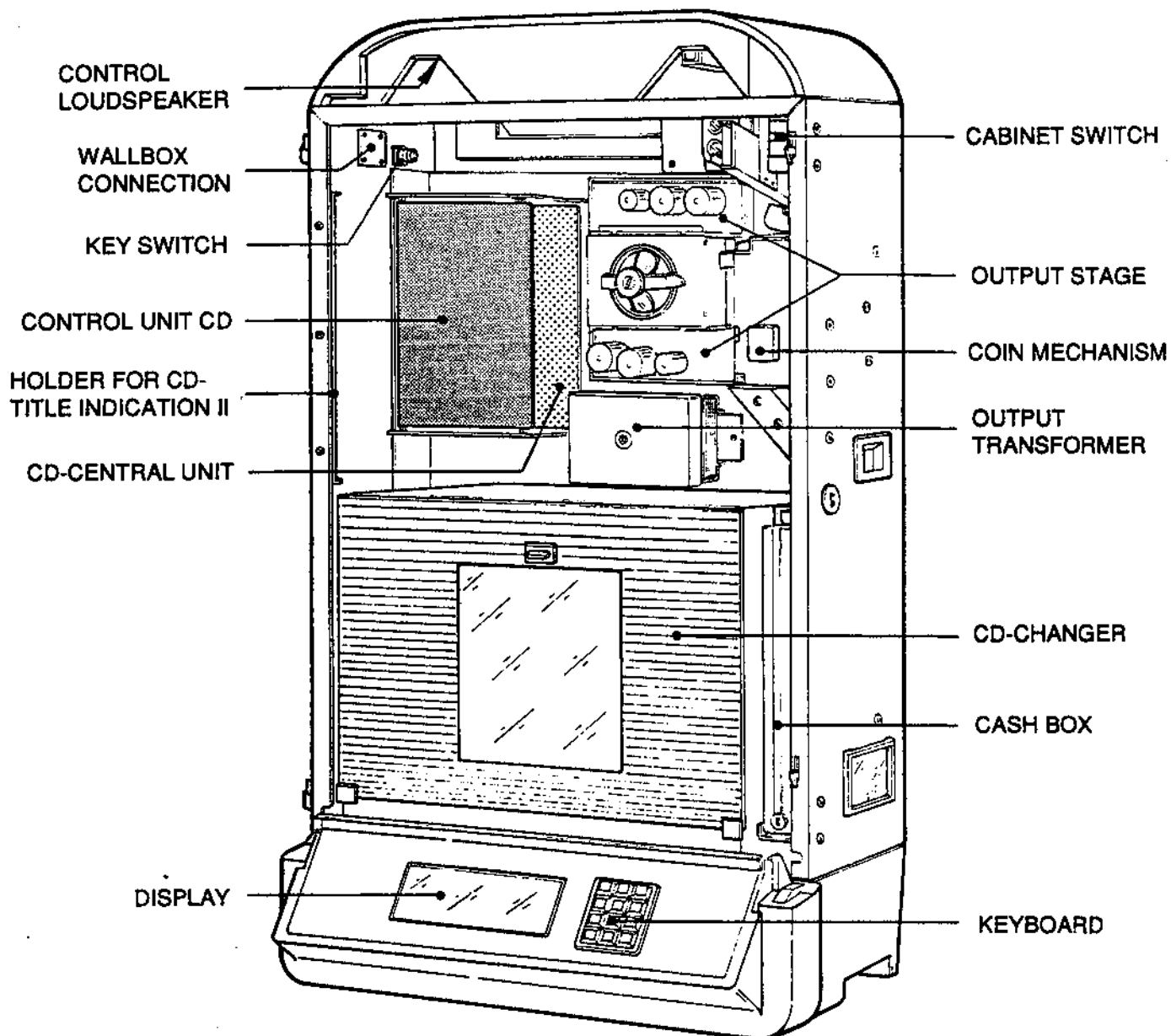

2.1 SELECTOR and DISPLAY PANEL

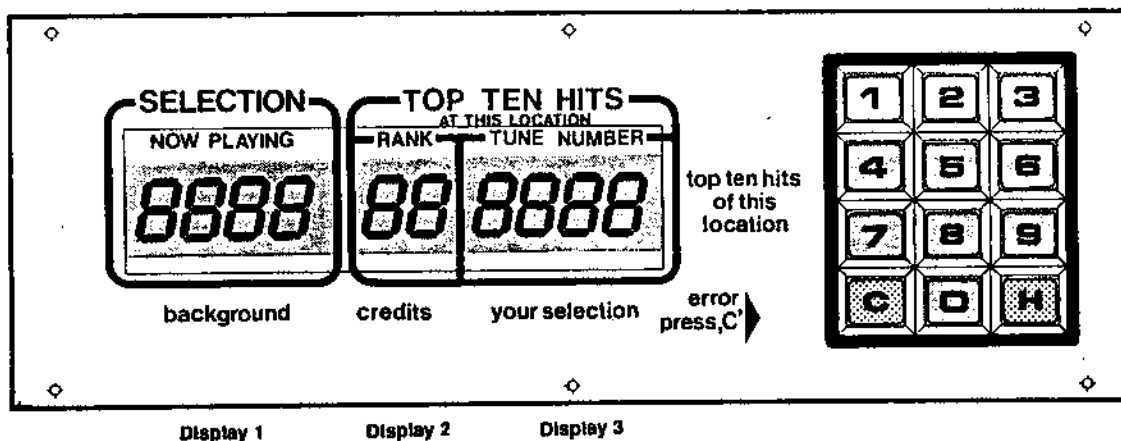

3 SPECIFICATIONS

3.1 Electrical Data

Main voltage: 100-260 V (variable), 50/60 Hz

Power consumption

at stand by 170 W
at play 450 W

3.2 Musik Power

2 x 200 watts music power at 2 ohms

3.3 Fuses

Replace fuses only with those of same value!

3.4 Lighting

Fluorescent lamps = 4 W
Fluorescent lamps = 8 W
Fluorescent lamps = 13 W

	THE WIZARD	OLD FASHION WIZARD
	4	2
	2	2
	2	1

Lamps = 12 V / 2 W

3.5 Credit / Cash Input

Maximum credit display is 99.

Price list adjustable individually or as per table.

Free credit adjustment / permanent credit key-operated switch for free credits and background, elect.-mech. cash counter (optional).

3.6 Keyboard

10 number keys 0-9
1 correction key "C"
1 hit-step key "H"

3.7 Displays

Display 1 with 4 seven-segment LED's
Display 2 with 2 seven-segment LED's
Display 3 with 4 seven-segment LED's
1 lamp display "10 top hits"
1 lamp display "background"
1 lamp display "credit"
1 lamp display "your selection"
1 lamp display "error, press key "C"

3.8 CD changer

NSM CD changer for maximum 100 CD's, 5 inch. Disc-player: Philips CD-player unit.

3.9 Loudspeakers

1 loudspeaker SP-3 R 8 ohms (control loudspeaker)

3.10 Special Features

Integrated microphone preamplifier and connection socket for microphone with paging switch.
Computer-controlled amplifier protection for overload (mismatch).

3.11 Dimensions

Height	39,6 inch
Width	23,8 inch
Depth	14,2 inch

4 LOUDSPEAKER CONNECTION

The wallbox is equipped with a control loudspeaker. For service or repair it can be connected to the terminals of one of the outputs (left or right channel) of the output stage.

The connection wires of the external loudspeakers are led through an opening in the lower cabinet part (left rear) to the inside, through the bottom in the cabinet corner upwards, and then to the connection terminals of the output stage.

The polarity ▼ must be maintained because otherwise bass reproduction would nullify itself!

The ES-V amplifier serves an output of 2 x 200 watts music power at 2 ohms per channel.

If the loudspeaker impedance is 4 ohms, the loudspeaker will use 2 x 100 watts musik power (Fig. 1) from the amplifier.

In that case, the additional loudspeakers connected cannot have an impedance of less than 4 ohms since the amplifier otherwise would be "mismatched" and the overload protection would operate.

If loudspeakers with a higher impedance are connected (Fig. 2), a number of speakers can be connected parallel. In that case, a loudspeaker with a higher impedance would naturally be lower in volume.

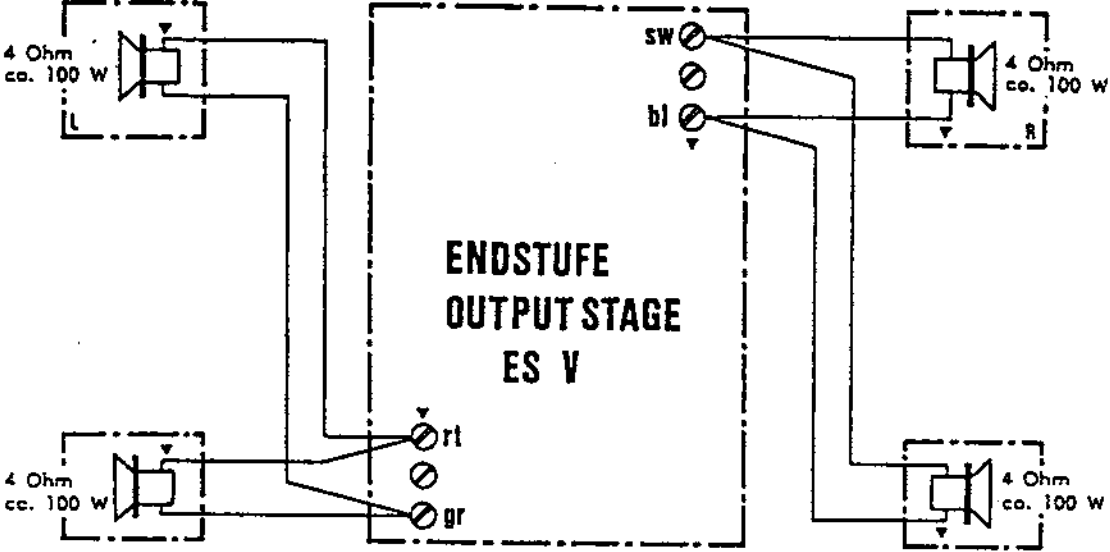

Fig. 1

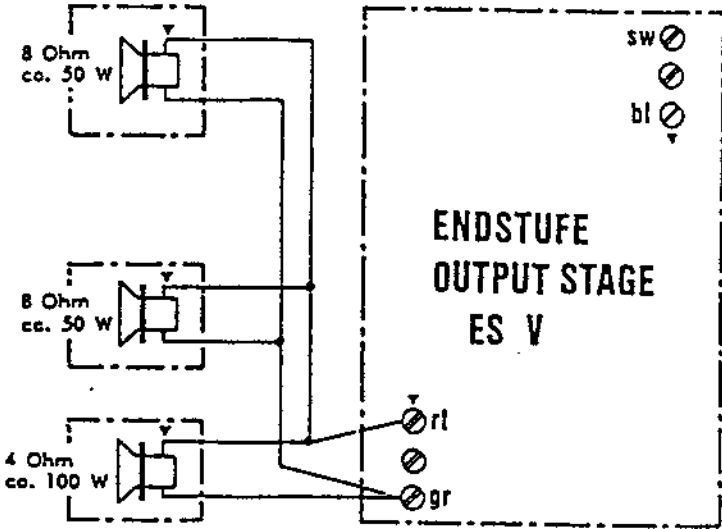

Fig. 2

Mono mode; sound system for separate rooms; see Fig. 3.

If the volume is to be controlled independently from 2 rooms, both cabinet speakers can be connected to one channel. The loudspeaker for the other room can then be connected to the free channel. There for the switch S 1 in the Central Unit has to be put on "MONO". For this independent procedure a volume control with separate controls is necessary (see remote control).

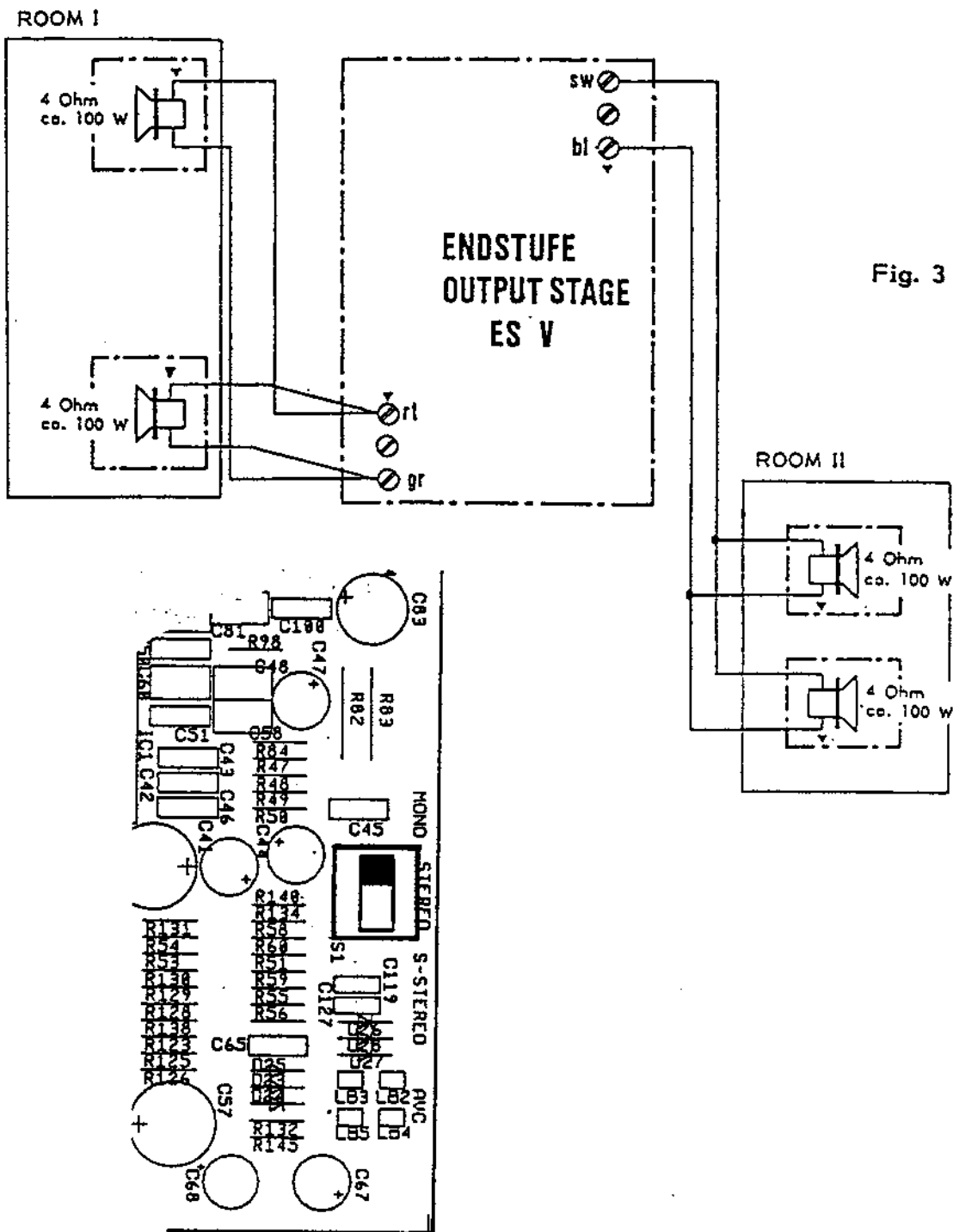

Fig. 3

Additional Loudspeakers and Separate Control

If even more speakers are to be connected whereby the total impedance drops below 2 ohms, an output transformer has to be used (see schematics "loudspeaker connection" and unit description "OUTPUT TRANSFORMER").

Cabinet speakers (Fig. 4) in serial connection result in lower volume!

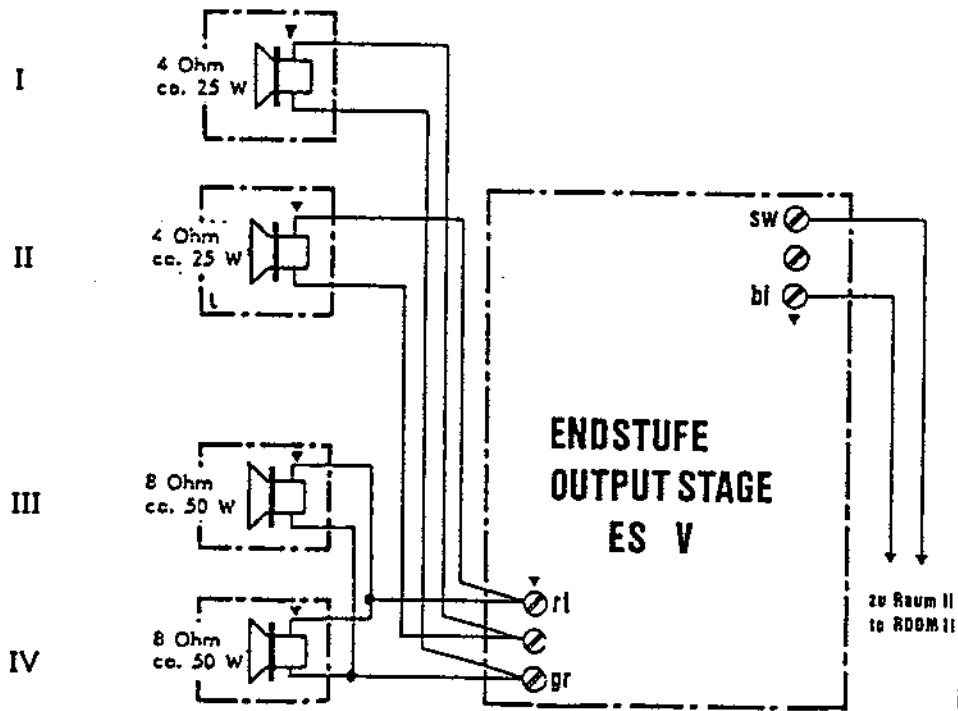

Fig. 4

An auxiliary amplifier can be connected for independent stereo control of other rooms as well as for increased power requirements.

See also unit description "Central Unit", connection of auxiliary amplifier, and "Accessories", tape recorder connection cable or CD-audio connection.

4.1 OUTPUT TRANSFORMER

Extension Speaker Operation

To avoid a poor sounding phonograph, care must be taken when adding extension speakers. Three requirements must be met:

- 1.) Speakers must be wired so that the power consumed by the phonograph speakers and the extension speakers, including walleets, does not exceed the amplifier power rating.
- 2.) Extension speakers should produce the desired sound level relative to the sound level of the speakers on the phonograph.
- 3.) All speakers must be connected with the correct polarity.

Several charts have been included to assist you with connecting the extension speakers. Figure 2-10 at the end of this section shows the entire sound system.

70-VOLT-SPEAKER

To avoid prohibitive cable losses on long speaker lines, 70-volt speakers should be used as much as possible.

The power level in the 70-volt speakers is set at each speaker.

Low Impedance 8-Ohm Speakers

Low impedance speakers (8 ohms) can be used when the connecting cable is less than 100 feet (AWG 18) / 0,75 mm².

The loss 100 feet (AWG 18)/0,75 mm² of zipcord feeding one 8-ohm speaker is 15 %. The loss for two 8-ohm speakers is 30 %.

4-OHM SPEAKERS

No more than one 4-ohm speaker should be connected to a speaker line. If several 4-ohm speakers are to be used, each speaker should have its own line.

Do not connect a low impedance speaker to a speaker tap that exceeds the speaker's power rating.

CAUTION:

In any speaker installation, the total speaker load (the sum of all power ratings of all speakers) must not exceed 400 watts Musik Power (2x200 W je Kanal).

SELECTING SPEAKER POWER

General Instructions

This section will lead you through the power and speaker selection process. This process consists of three major steps and several smaller steps. The major steps are:

- 1.) Identifying the extension speakers and computing the extension speaker power.
- 2.) Making the external speaker connections.
- 3.) Determining and selecting the phonograph power.

Step-By-Step Instructions

- 1.) Use a pencil (you may want to revise your figures) to fill in the work sheet on the following pages.

Use this work sheet to help you calculate the amount of power consumed by the extension speakers. Use table as a guide to help you select which power tap to use for each type of external speaker that you are using.

Place the quantity of stereo speaker in the blank under QTY and multiply the quantity times the power consumption (show stereo speakers as 2 speakers). Place your results in the TOTAL blank.

Table 1

4-OHM Stereo Speakers

	QTY	Total	Connections
Speakers for the 1,8 watt taps:	_____ at 1,8 watts each =	_____ watts	(0 to 1)
Speakers for the 7,5 watt taps:	_____ at 7,5 watts each =	_____ watts	(0 to 2)
Speakers for the 15 watt taps:	_____ at 15 watts each =	_____ watts	(0 to 3)
Speakers for the 30 watt taps:	_____ at 30 watts each =	_____ watts	(0 to 4)
Speakers for the 65 watt taps:	_____ at 65 watts each =	_____ watts	(0 to 5)
Speakers for the 100 watt taps:	_____ at 100 watts each =	_____ watts	(direkt to Amplifiere)
	Total blank 4-Ohm =	_____	

8-Ohm Stereo Speakers

	QTY	Total	Connections
Speakers for the 1 watt taps:	_____ at 1 watts each =	_____ watts	(0 to 1)
Speakers for the 4 watt taps:	_____ at 4 watts each =	_____ watts	(0 to 2)
Speakers for the 8 watt taps:	_____ at 8 watts each =	_____ watts	(0 to 3)
Speakers for the 16 watt taps:	_____ at 16 watts each =	_____ watts	(0 to 4)
Speakers for the 35 watt taps:	_____ at 35 watts each =	_____ watts	(0 to 5)
Speakers for the 50 watt taps:	_____ at 50 watts each =	_____ watts	(direkt to Amplifiere)
	Total blank 8-Ohm =	_____	

70-VOLT SPEAKERS

70-Volt speakers have a power tap on them or on their associated transformer. Add together all of the 70-volt speaker tap settings and enter that value:

_____ watts (A1 to A2)
(B1 to B2)

Combine all speaker's consumptions:

Stereo

4 Ohm _____

8 Ohm _____

70 Volt _____

Subtract the Grand Total from 400 and write the result in the blank at the end of this line:
 Power Available For The Phonograph _____

The Grand Total is the amount of power that the phonograph will need to supply to the extension speakers. This amount must be less than 400 watts. If this amount is not less than 400 watts, you must reduce the power used by the extension speakers to reduce the total power consumed; then recalculate the total power consumed. (andere Klemme anschließen).

When you subtract the Grand Total from 400, you will get the "Power Available For The Phonograph" figure. Be sure to write this value down in the blank because you will not be using it until you have wired all of the extension speakers.

NOTE:
 The amplifier may be connected to a load of 400 watts before distortion will begin to increase beyond specification.

The phonograph wires to change are the red (left channel) and the blue (right channel) on the output transformer assembly (see table 2).
 Use table 2 as a guide to select the power used by the phonograph. This power should roughly match the amount indicated in "Power Available For The Phonograph" on the previous page.

Table 2

Phonograph Speaker Power

Select the speaker taps that will use up most of the "available Speaker Power".
 You may select more power or less phonograph power to suit you phonograph volume preference.

Phono Power *) [W]	Phono Speaker Connections
2,4	Red connects to Left E1, blue connects to Right E1
11,0	Red connects to Left E2, blue connects to Right E2
22,0	Red connects to Left E3, blue connects to Right E3
44,0	Red connects to Left E4, blue connects to Right E4
100	Red connects to Left E5, blue connects to Right E5
140	Red connects to Left direkt Amplifier, blue connects to Right direkt Amplifiere

Do not move the Black wire; it should stay on either the Left or Right E1 terminal.

*) This value is the total for both channels. The power consumption for each channel is one-half of this value.

Check that the phonograph is not overloaded by performing the following four steps:

- A. Make sure that the phonograph and extension speakers are connected to the proper speaker taps.
- B. Set the volume control fully clockwise (maximum volume) and make a selection.
- C. While the music is playing, an acceptable load will allow the OVERLOAD INDICATOR(S) to be off or occasionally flicker in a random manner. If the OVERLOAD INDICATOR(S) are always lit or flicker continuously, the amplifier is overloaded and you must perform step D.
- D. Do this step only if the OVERLOAD INDICATOR(S) came on as described in the previous step. Find the source of the overload (shorted speaker wires or too many speakers on line) and repeat step C.

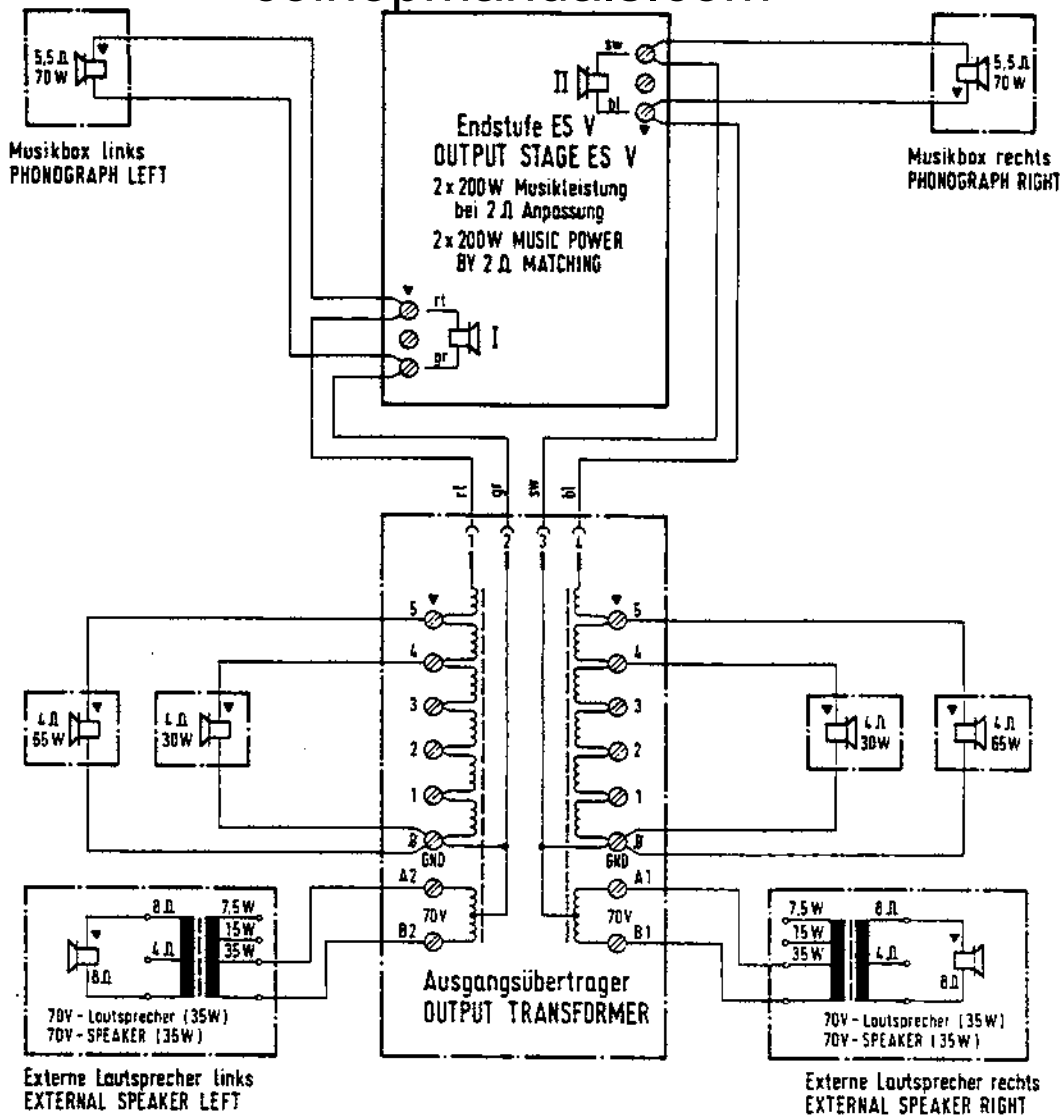

Anschlussschema für Ausgangsübertrager
 CONNECTION DIAGRAM FOR OUTPUT TRANSFORMER

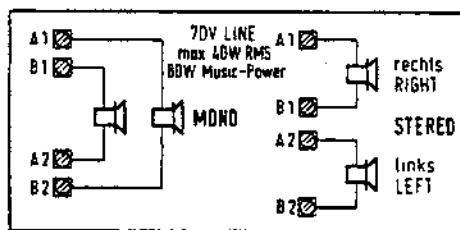

Klemme TERMINAL POSITION	Lautsprecher SPEAKER				
	2 Ω	2.5 Ω	4 Ω	8 Ω	16 Ω
0 - 5	130 W	100 W	65 W	35 W	18 W
0 - 4	60 W	48 W	30 W	15 W	8 W
0 - 3	30 W	24 W	15 W	8 W	4 W
0 - 2	15 W	12 W	7.5 W	4 W	2 W
0 - 1	3.7 W	3 W	1.8 W	1 W	0.5 W

ÄNDERUNGEN IM SINNE DES TECHN. FORTSCHRITTES VORBEHALTEN,
 JEDOCH KEINE WACHSTPFLICHT!
 SUBJECT TO TECHNICAL MODIFICATION WITHOUT OBLIGATION
 TO MODIFY EQUIPMENT ALREADY DELIVERED!

NSM MUSIKAUTOMATEN PHONOGRAPHS **ES V-CD** TECHNOLOGY

Lautsprecheranschluss
 SPEAKER CONNECTION

Anschluß für max. Ausgangsleistung
 CONNECTION FOR MAX. POWER OUTPUT

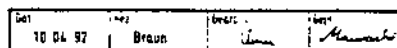

**SPARE PARTS LIST
FOR NSM-PHONOGRAPH
THE WIZARD
OLD FASHION WIZARD**

This spare parts list is applicable for NSM-Phonograph: **THE WIZARD
OLD FASHION WIZARD**

Every spare part order should contain the following:

1. Model
2. Serial number
3. Quantity
4. Part number
5. Description

Example

Model	Serial-Number	QTY	Part-No.	Description	Data
THE WIZARD OLD FASHION WIZARD	02 904	1	223 423	MAINS TRANSFO	VG 13/2 KY S2
		2	224 188	BALLAST	
		1	225 343	STARTER	

ATTENTION!

Precise orders save unnecessary questions and bring the best results.

ORDER SPARE PARTS THRU YOUR NSM-DISTRIBUTOR!

Information and illustrations contained in this spare parts list, are correct at the time of going to press.

NSM-AKTIENGESELLSCHAFT, Saarlandstraße 240 - 6530 BINGEN am Rhein

INDEX

Page 123	UNITS and ACCESSORIES
Page 124-127	CABINET
Page 128-131	FRONT FRAME -THE WIZARD-
Page 131	BUTTON
Page 132-135	FRONT FRAME -OLD FASHION WIZARD-
Page 136	CABLE HARNESSSES

SPARE PARTS LIST

POS.	PART-No.	DESCRIPTION	DATA	QTY
------	----------	-------------	------	-----

PHONOGRAPH "THE WIZARD"
"OLD FASHION WIZARD"

UNITS

176 328	CB-CONTROL UNIT ES V, ASSY		see page 400 ...	1
173 664	CB-DISPLAY CD, ASSY		see page 500 ...	1
176 326	CENTRALE ES V, ASSY	50 Hz	see page 600 ...	>
176 327	CENTRALE ES V, ASSY	60 Hz	see page 600 ...	1
171 701	OUTPUT STAGE, ASSY	50 Hz	see page 700 ...	>
171 702	OUTPUT STAGE, ASSY	60 Hz	see page 700 ...	1
176 360	CD-CHANGER, ASSY (without Design Pieces)		see page 800 ...	1
176 362	VIEW GLASS, MOUNT.			1
175 316	TRIMPLATE, ASSY			1
176 832	CD-TITLE INDICATION III, ASSY		see page 900 ...	1
040 739	MOUNTING BRACKET, ASSY			1

ACCESSORIES

171 799	OUTPUT TRANSFORMER			1
172 504	CABLE HARNESS			1
174 258	IR-REMOTE CONTROL, ASSY		with 5 m Cable	1
206 783	SENDER			1
173 178	RECEIVER			1
171 743	REMOTE CONTROL		with 5 m Cable	1
172 077	REMOTE CONTROL		with 25 m Cable	1
173 996	WALLBOX-CONNECTION, ASSY			1
173 464	WALLBOX-ADAPTER, ASSY			1
223 422	TRANSFORMER			1
173 997	CABLE HARNESS: TRANSF. -- ADAPTER			1
173 998	CABLE HARNESS: WALLBOX-ADAPTER			1
209 944	INSTALLATION INSTRUCTIONS			1

SPARE PARTS LIST

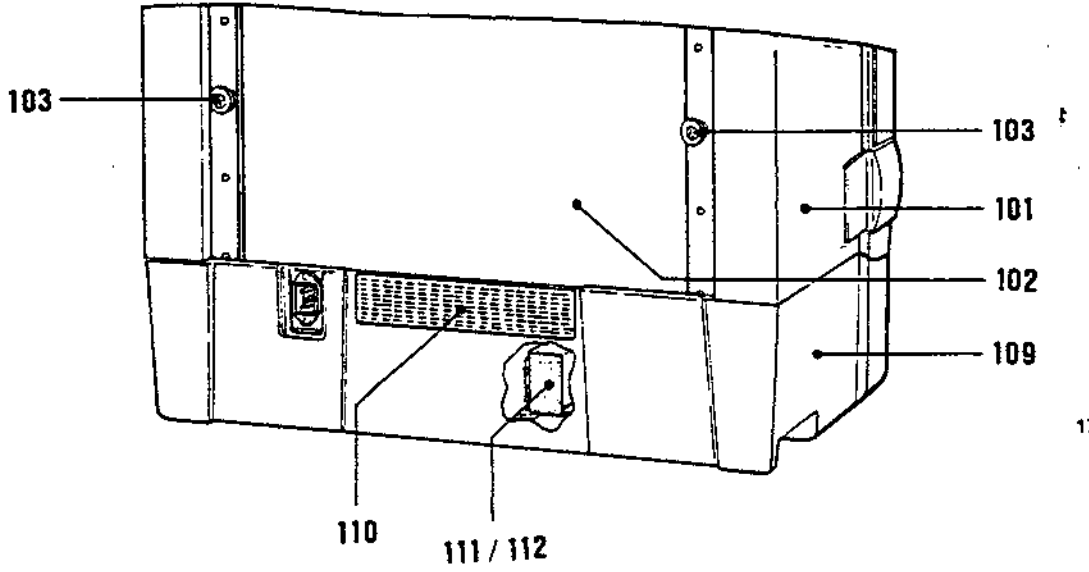
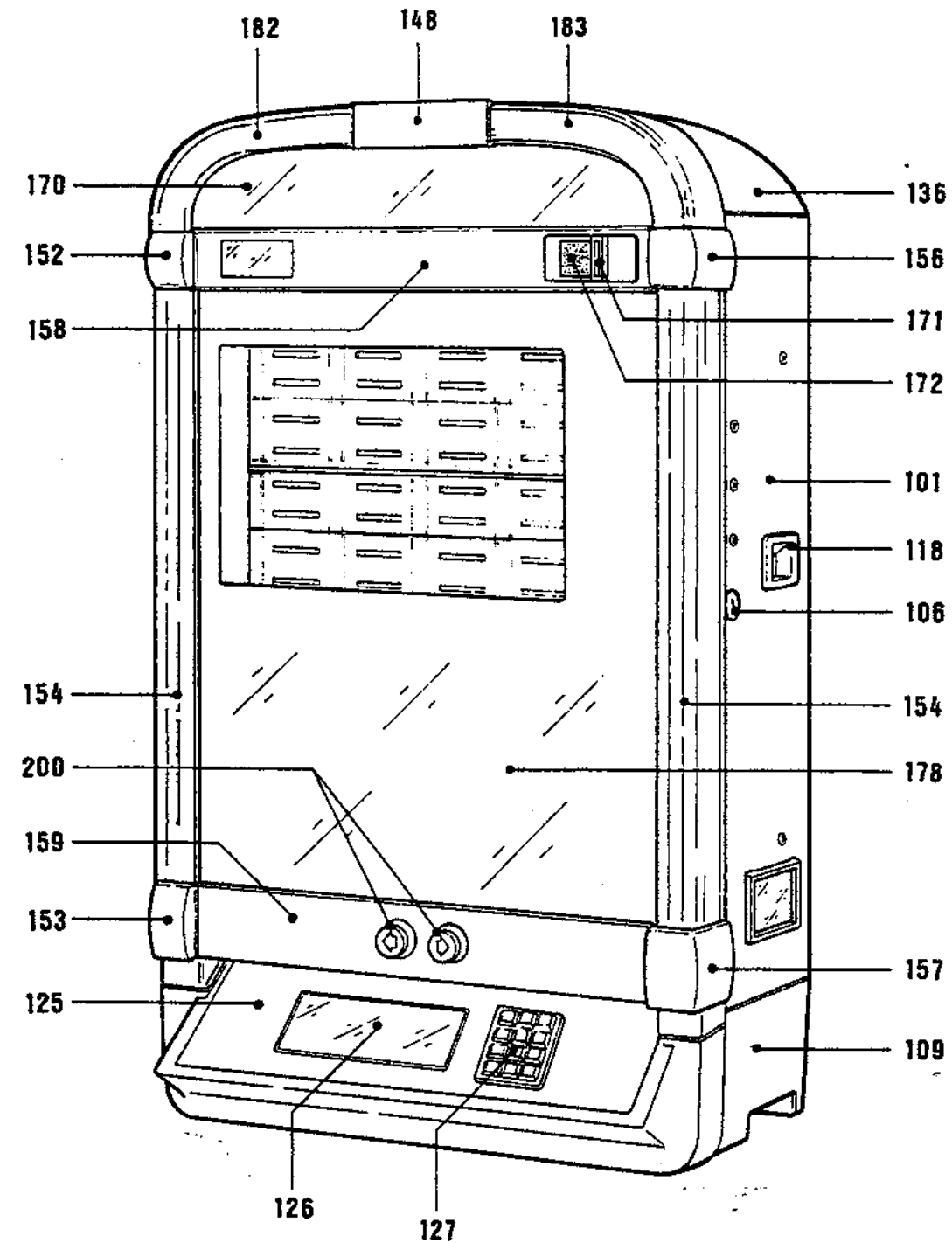

SPARE PARTS LIST

POS.	PART-No.	DESCRIPTION	DATA	QTY
<u>PHONOGRAPH "THE WIZARD"</u>				
<u>"OLD FASHION WIZARD"</u>				
101	175 711	CABINET, PRE-MOUNTED	not for USA	>
	175 866	CABINET, PRE-MOUNTED	for USA only	1
102	211 675	BACK COVER		1
103	112 462	GUIDE PARTS		4
104	114 674	CLOSING RAIL, ASSY		1
105	211 474	CLOSING BRACKET		2
106	206 676	LOCK		1
	206 718	SPARE KEY		1
107	112 959	CLOSED, STAMPED		1
	205 722	TENSION SPRING		1
108	113 326	HINGE-BOTTOM PART, ASSY		2
109	173 501	BOTTOM PART		1
110	175 750	VENTILATION PLATE I		1
111	173 697	TRANSFO PLATE		1
112	223 423	MAINS TRANSFORMER		1
114	222 505	KEY SWITCH		1
115	175 860	COIN TUBE (CASH BOX)		1
	174 377	COVER PLATE		1
116	173 725	COIN RETURN LEVER, STAMPED		1
	173 726	BAFFLE LEVER, STAMPED		1
117	173 655	COIN RETURN PLUNGER		1
	205 265	PRESSURE SPRING	(COIN MECHANISM)	1
	173 727	HOLDING BRACKET, STAMPED		1
	175 708	FLAT SPRING		1
118	029 335	COIN RETURN CUP		1
	102 495	COIN LID		1
119	172 139	CB-MARS-COIN ACCEPTOR, ASSY		1
120	222 509	PUSH BUTTON SWITCH	CABINET SWITCH	1
121	176 303	BRACKET, ASSY RIGHT	for CENTRALE and	1
122	176 304	BRACKET, ASSY LEFT	CONTROL UNIT	1
123	174 383	CASH-BOX		1
124	206 656	Cyl.-LOCK		1
	173 908	CLOSING LEVER		1
125	173 708	CONSOLE		1
126	174 014	GLASS, PRINTED	GERMAN	>
	173 794	GLASS, PRINTED	ENGLISH	1
127	171 676	KEY BOARD, ASSY		1

SPARE PARTS LIST

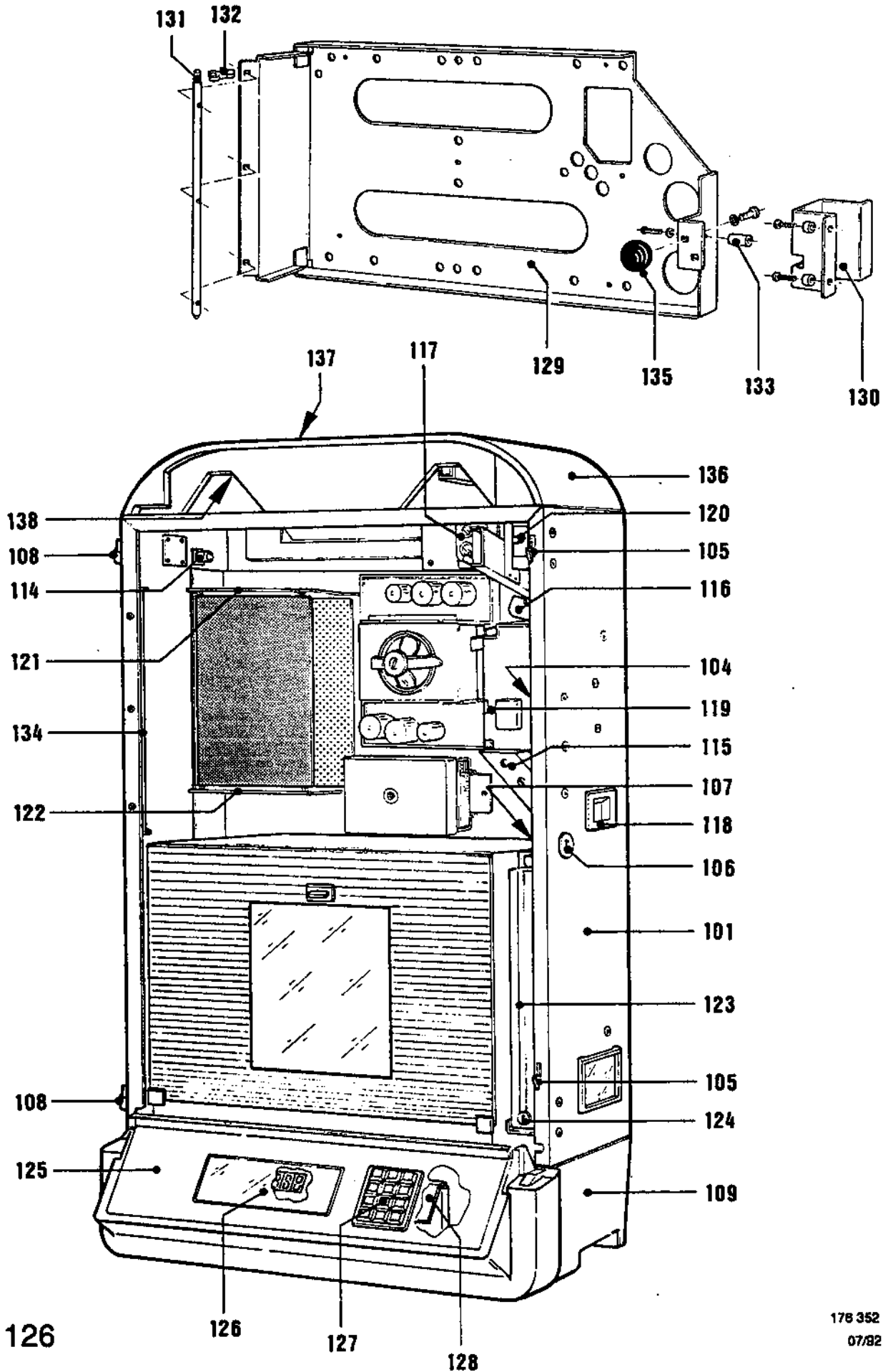

SPARE PARTS LIST

POS.	PART-No.	DESCRIPTION	DATA	QTY	
128	173 670	LAMP MASK		1	
	225 587	LAMP SOCKET		1	
	226 056	LAMP	12 V 2 W	1	
129	176 020	BACK PLATE II	}	1	
130	176 022	LOCKING PLATE II		1	
131	176 023	AXLE		f. TITLE	1
132	175 204	CLIP		INDICATION II	1
133	176 024	BUSHING			1
134	176 048	BEARING PLATE II			1
135	217 391	BALL HANDLE			1

GUARD

	136	114 654	GUARD		1
	137	175 751	VENTILATION PLATE II		1
	138	174 004	CONTROL-LOUDSPEAKER, ASSY		1
BY WIZARD ONLY		173 777	HOLDING PLATE		1
		224 215	BALLAST	KX 4/6/8 D 8 W	2
		224 188	BALLAST	KX 13 D	3
		223 421	PRE-TRANSFORMER	for 117 V only	1

SPARE PARTS LIST

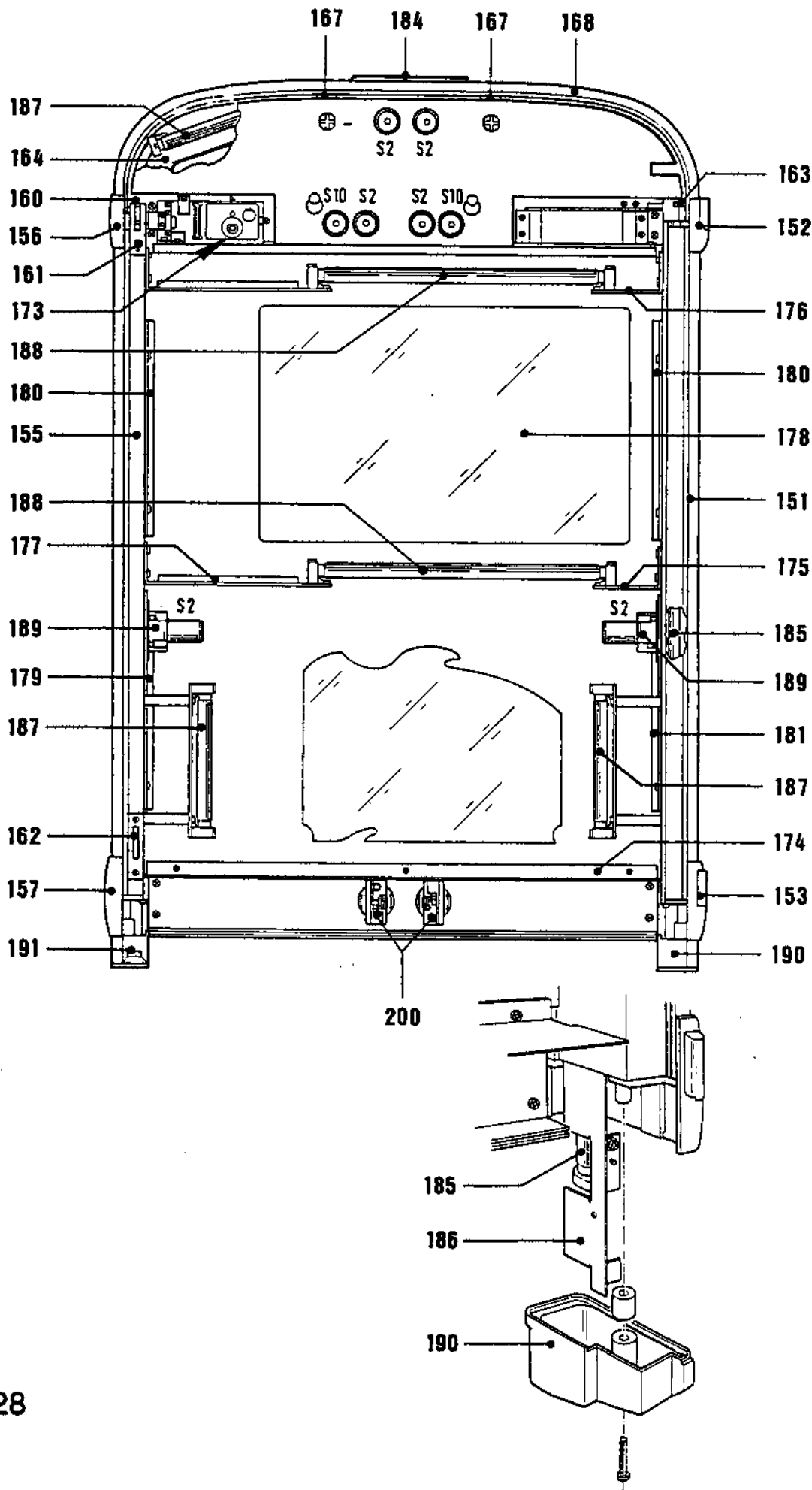

SPARE PARTS LIST

POS.	PART-No.	DESCRIPTION	DATA	QTY
150	176 572	<u>FRONT FRAME "THE WIZARD"</u>		
151	250 336	LONGITUDINAL PROFILE, LEFT		1
152	250 273	EDGE CONNECTOR, UPPER LEFT		1
153	250 275	EDGE CONNECTOR, LOWER LEFT		1
154	212 422	LAMP MASK		1
155	250 337	LONGITUDINAL PROFILE, RIGHT		1
156	250 274	EDGE CONNECTOR, UPPER RIGHT		1
157	250 276	EDGE CONNECTOR, LOWER RIGHT		1
154	212 422	LAMP MASK		1
158	176 475	CROSS PROFILE, UPPER ASSY		1
159	176 474	CROSS PROFILE, LOWER ASSY		1
160	115 082	HOLDING BRACKET, RIGHT		1
161	114 679	CLOSING PLATE, UPPER		1
162	114 680	CLOSING PLATE, LOWER		1
163	115 083	HOLDING BRACKET, LEFT		1
164	175 494	CARRIER PLATE, STAMPED		1
167	114 682	HOLDING BRACKET		2
168	250 340	TERMINAL PROFILE, UPPER CURVED		1
170	212 601	FRONT PLATE		1
	206 581	DUPLEX PROFILE		1
171	173 710	COIN INSERT		1
172	175 023	BUTTON I, PRE-MOUNTED		1
173	205 720	PRESSURE SPRING		1
	209 963	MASK, LEFT		1
	209 964	MASK, RIGHT		1
174	173 905	COVER, LOWER		1
175	175 033	LAMP HOLDER, LEFT LOWER		1
176	175 227	LAMP HOLDER, LEFT UPPER		1
177	175 032	LAMP HOLDER, RIGHT		2
178	214 005	FRONT GLASS		1
	206 519	RUBBER PROFILE		2
	206 520	RUBBER PROFILE		2
179	175 037	GLASS HOLDER, RIGHT LOWER		1
180	175 034	GLASS HOLDER, UPPER		2
181	175 035	GLASS HOLDER, LEFT LOWER		1
182	175 469	LAMP MASK, UPPER LEFT		1
183	175 468	LAMP MASK, UPPER RIGHT		1
184	176 141	SOCKET for MASK		1

SPARE PARTS LIST

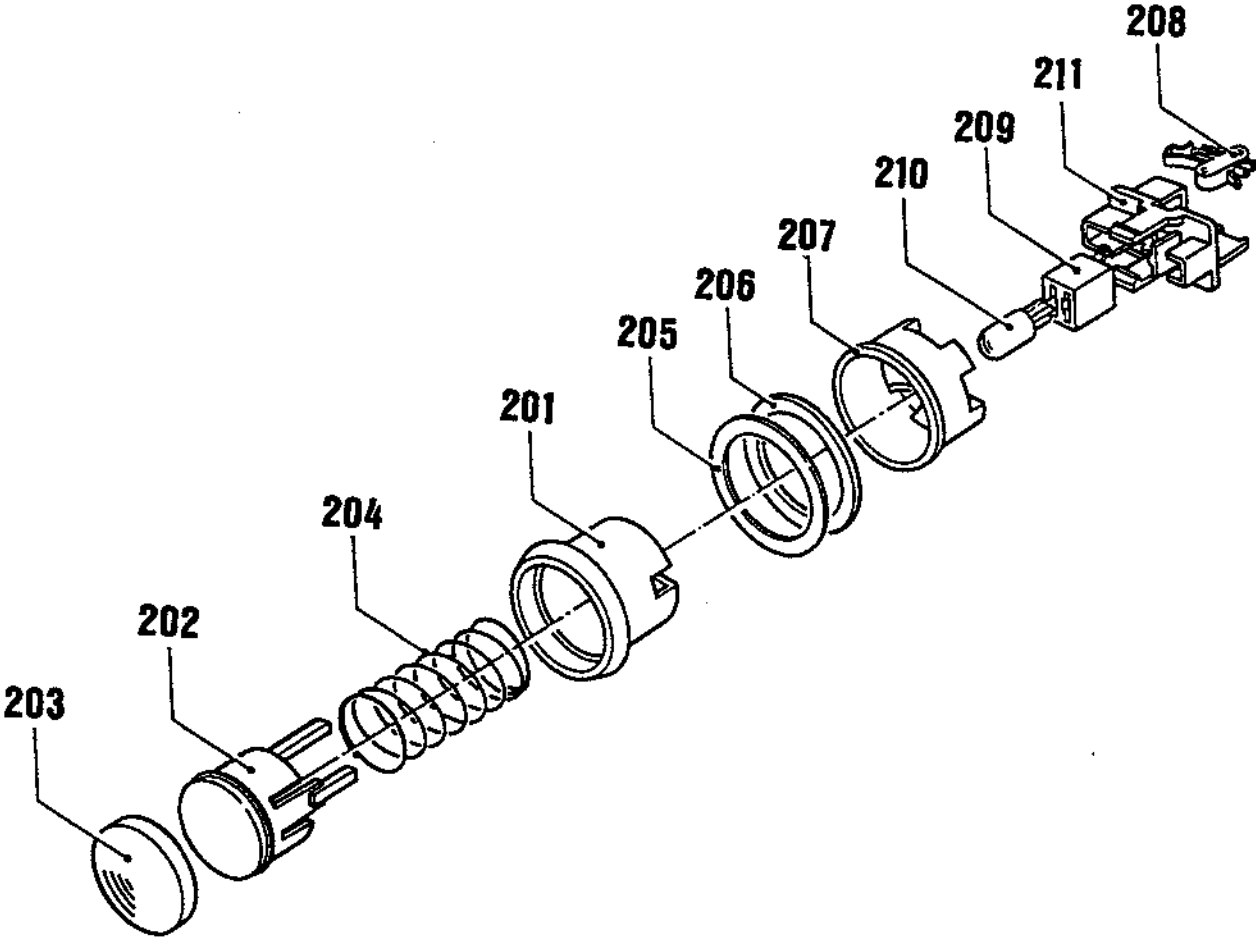

SPARE PARTS LIST

POS.	PART-No.	DESCRIPTION	DATA	QTY
185	226 075	FLUORESCENT LAMP	13 W	2
186	175 065	LAMP HOLDER, LEFT PRE-MOUNTED		1
	175 066	LAMP HOLDER, RIGHT PRE-MOUNTED		1
187	226 072	FLUORESCENT LAMP	4 W	4
	209 845	FOIL, SHORT		4
	219 576	FOIL, LONG		2
188	226 079	FLUORESCENT LAMP	8 W	2
189	225 364	STARTER HOLDER		6
	225 343	STARTER	S 2	4
	225 040	STARTER	S10	2
190	173 712	ADAPTER, LEFT		1
191	173 711	ADAPTER, RIGHT		1
200	174 448	<u>BUTTON, ASSY</u>		2
201	115 608	HOUSING	small round	2
202	174 741	BUTTON, PRINTED		2
203	115 627	BUTTON, COVER	small round	2
204	205 798	PRESSURE SPRING		2
205	206 615	RING (0,5 mm thickness)		2
206	175 048	RING (2,5 mm thickness)		2
207	115 612	COVER		2
208	222 515	MICRO SWITCH		2
209	225 587	LAMP SOCKET		2
210	226 049	LAMP	12 V 2 W	2
211	115 611	ADAPTER		2

SPARE PARTS LIST

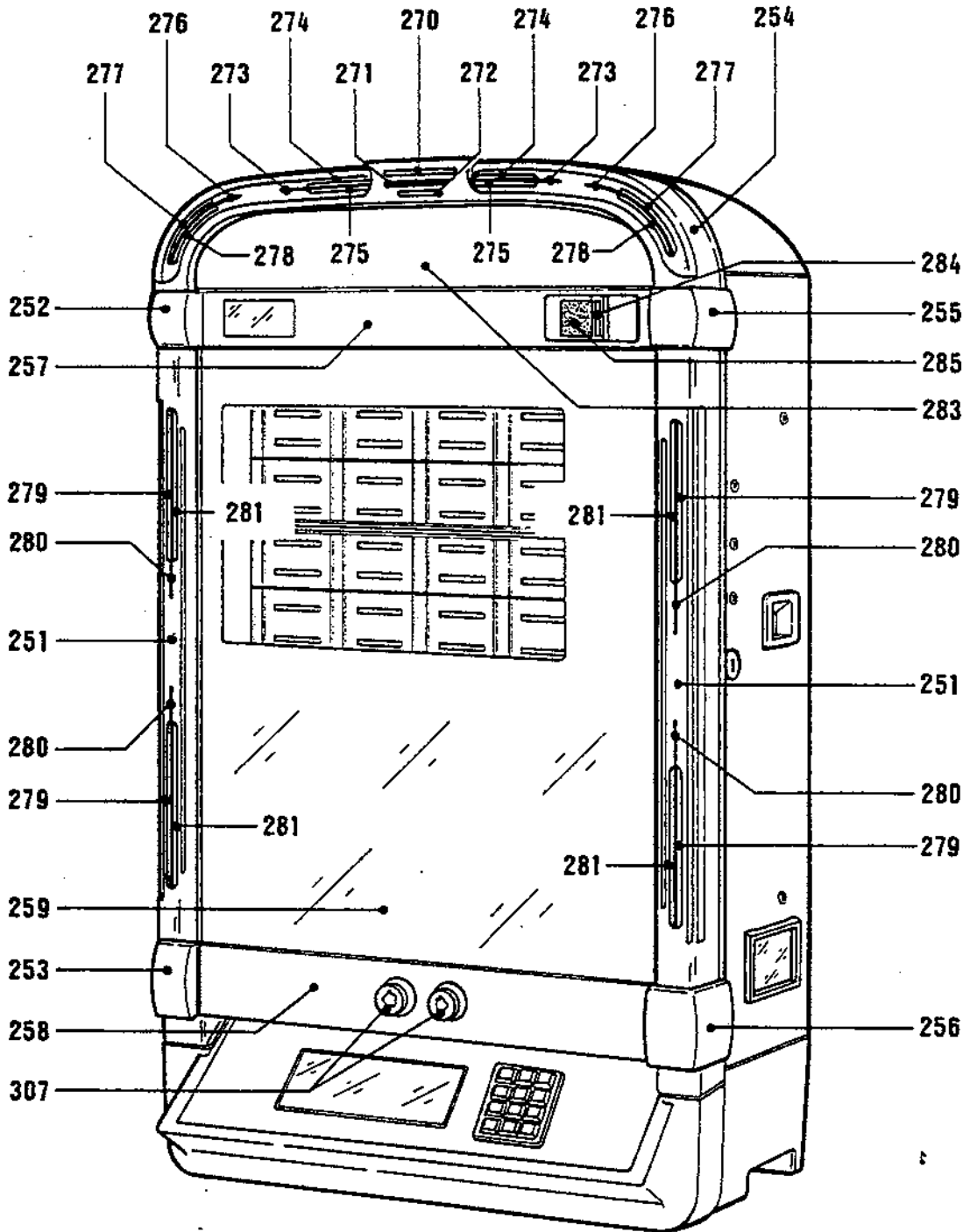

SPARE PARTS LIST

POS.	PART-No.	DESCRIPTION	DATA	QTY
250	176 573	FRONT FRAME "OLD FASHION WIZARD"		
251	176 228	FRAME PIECES, LEFT and RIGHT	DESIGN WOOD	2
252	250 320	EDGE CONNECTOR, UPPER LEFT		1
253	250 321	EDGE CONNECTOR, LOWER LEFT		1
254	176 230	FRAME PIECES, UPPER	DESIGN WOOD	1
255	250 322	EDGE CONNECTOR, UPPER RIGHT		1
256	250 323	EDGE CONNECTOR, LOWER RIGHT		1
257	176 924	CROSS PROFILE, UPPER ASSY		1
258	175 041	CROSS PROFILE, LOWER ASSY		1
260	115 082	HOLDING BRACKET, RIGHT		1
261	114 679	CLOSING PLATE, UPPER		1
262	114 680	CLOSING PLATE, LOWER		1
263	115 083	HOLDING BRACKET, LEFT		1
264	176 210	CARRIER PLATE, STAMPED		1
265	250 314	PROFIL for LAMP MASK, LEFT		1
266	250 315	PROFIL for LAMP MASK, RIGHT		1
267	176 211	HOLDING BRACKET		2
268	250 316	TERMINAL PROFILE, UPPER, CURVED		1
270	176 213	LIGHT SPOT, UPPER MIDDLE I	yellow	1
271	176 214	LIGHT SPOT, UPPER MIDDLE II	darkred	1
272	176 215	LIGHT SPOT, UPPER MIDDLE III	yellow	1
273	176 216	LIGHT SPOT, UPPER RIGHT and LEFT I	darkred	2
274	176 217	LIGHT SPOT, UPPER RIGHT and LEFT II	yellow	2
275	176 218	LIGHT SPOT, UPPER RIGHT and LEFT III	yellow	2
276	176 219	LIGHT SPOT, CURVED I	darkred	2
277	176 220	LIGHT SPOT, CURVED II	yellow	2
278	176 221	LIGHT SPOT, CURVED III	yellow	2
279	176 222	LIGHT SPOT, SIDE PART I	yellow	4
280	176 223	LIGHT SPOT, SIDE PART II	darkred	4
281	176 224	LIGHT SPOT, SIDE PART III	yellow	4
283	212 664	TRIMPLATE, UPPER		1
	206 581	DUPLEX-PROFILE		1
284	173 710	COIN INSERT		1
285	175 023	BUTTON I, PRE-MOUNTED		1
286	205 720	PRESSURE SPRING		1
	209 963	MASK, LEFT		1
	209 964	MASK, RIGHT		1
287	173 905	COVER		1

SPARE PARTS LIST

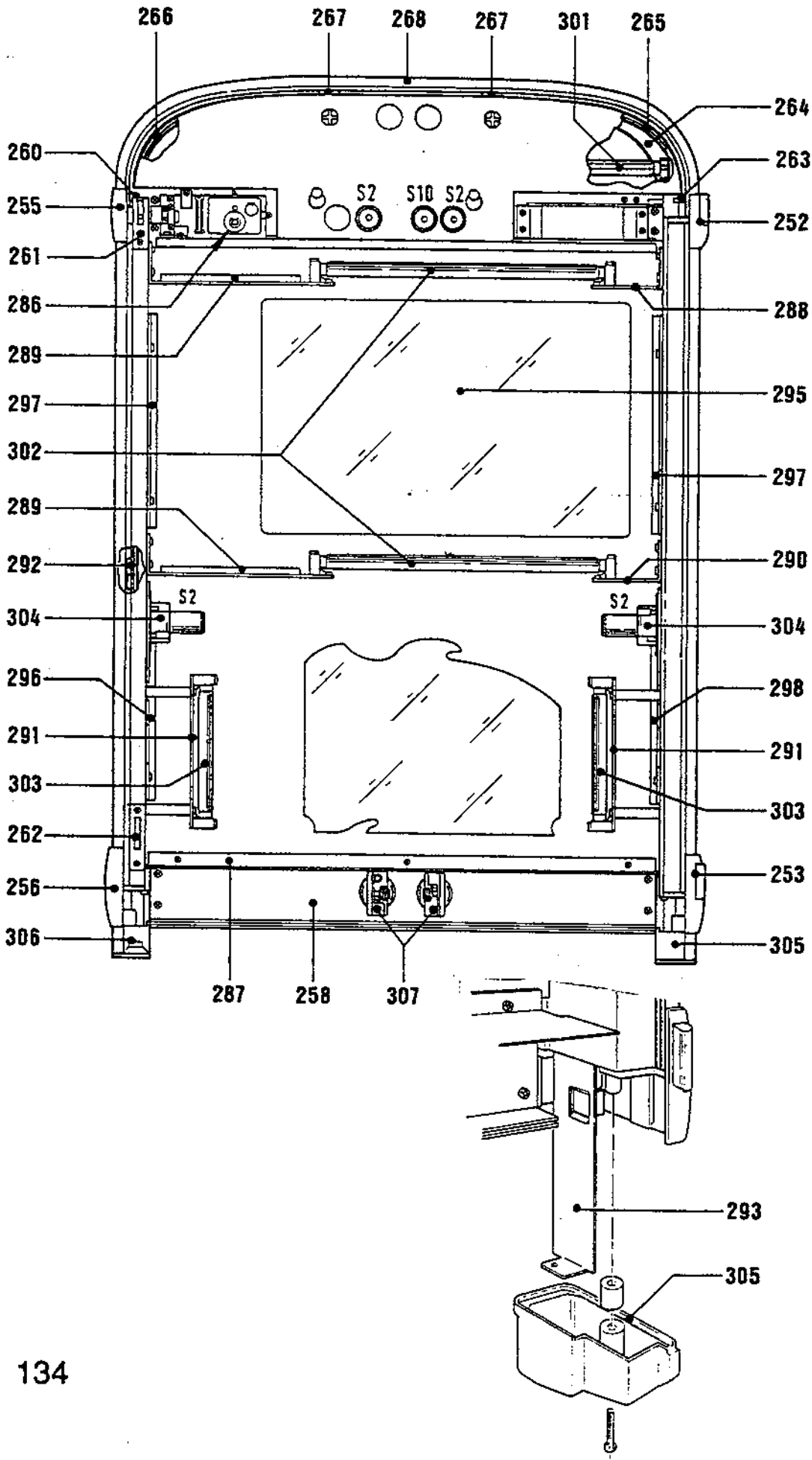

SPARE PARTS LIST

POS.	PART-No.	DESCRIPTION	DATA	QTY
288	175 227	LAMP HOLDER, LEFT, UPPER		1
289	175 032	LAMP HOLDER, RIGHT		2
290	175 033	LAMP HOLDER, LEFT, LOWER		1
291	173 999	LAMP HOLDER		2
292	176 196	LAMP HOLDER, RIGHT, PRE-MOUNT.		1
293	176 197	LAMP HOLDER, LEFT, PRE-MOUNT.		1
295	214 009	FRONT GLASS		1
	206 519	RUBBER PROFILE		2
	206 520	RUBBER PROFILE		2
296	175 037	GLASS HOLDER, RIGHT LOWER		1
297	175 034	GLASS HOLDER, UPPER		2
298	175 035	GLASS HOLDER, LEFT LOWER		1
301	226 075	FLUORESCENT LAMP	13 W	1
302	226 079	FLUORESCENT LAMP	8 W	2
	219 607	FOIL	LAMP, LOWER	1
303	226 072	FLUORESCENT LAMP	4 W	2
	209 845	FOIL	SHORT	2
	225 364	STARTER HOLDER		2
	225 040	STARTER	S 10	2
	225 343	STARTER	S 2	4
305	173 712	ADAPTER, LEFT		1
306	173 711	ADAPTER, RIGHT		1
307	174 448	BUTTON, ASSY	see page 131	2

SPARE PARTS LIST

POS.	PART-No.	DESCRIPTION	DATA		QTY
<u>CABLE HARNESSSES</u>					
171 782		CENTRALE -- CONTROL UNIT	120 lg	15 prongs	1
171 783		CENTRALE -- CONTROL UNIT	120 lg	12 prongs	1
174 012		DISPLAY, ASSY			1
174 000		CENTRALE -- OUTPUT STAGE			2
174 022		CENTRALE -- MAINS TRANSFORMER			1
176 386		KEY- and CABINET SWITCH			1
174 030		KEY BOARD -- LIGHTING			1
176 336		MAINS WIRING		220/240 V	>
176 337		MAINS WIRING		100/127 V	1
176 490		CD-AUDIO			1
175 223		CONTROL UNIT -- CB-TITLE DRUM			1
114 085		CENTRALE -- CD-PLAYER	600 lg	12 prongs	1
115 221		CONTROL UNIT -- CD PLAYER	600 lg	8 prongs	1
176 338		BALLASTS		220/240 V	>
176 339		BALLASTS		100/127 V	1
175 067		KEYS			1
175 567		SERVICE-EXTENSION			1
176 456		BALLASTS (by OLD FASHION WIZARD)		220/240 V	>
176 457		BALLASTS (by OLD FASHION WIZARD)		100/127 V	1
174 047		DOLLAR BILL ACCEPTOR -- CONTROL UNIT (for USA)			1

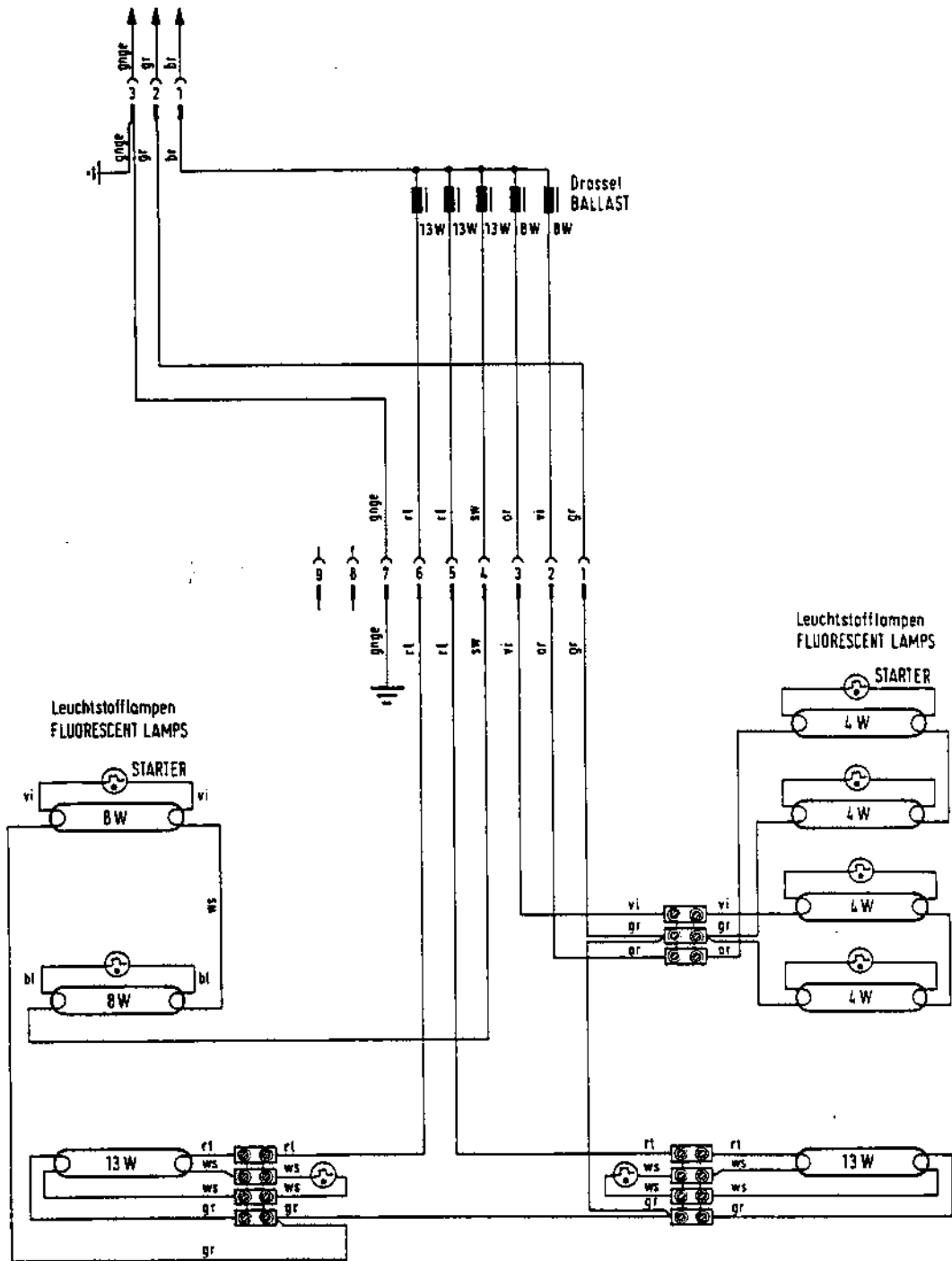

Farb Spiegel
COLOR CODE

ws	weiß	white
bl	blau	blue
br	braun	brown
ge	gelb	yellow
gn	grün	green
gr	grau	grey
or	orange	orange
rs	rosa	pink
rt	rot	red
sw	schwarz	black
vi	violett	violet

Farbangaben ohne Gewähr.
COLOR INDICATION WITHOUT WARRANTY.

ÄNDERUNGEN IM SINNE DES TECH. FORTSCHRITTES VORBEHALTEN,
JEDOCH KEINE NACHRÜSTPFLICHT!

SUBJECT TO TECHNICAL MODIFICATION WITHOUT OBLIGATION
TO MODIFY EQUIPMENT ALREADY DELIVERED!

NSM MUSIKAUTOMATEN ES V-CD TECHNOLOGY
PHONOGRAPHES

Schaltbild Beleuchtung [50 HZ]
WIRING DIAGRAM ILLUMINATION

THE
WIZARD

Dat 26.06.92 Gez Braun Gearb Gepr

Zum Netz-Transformator
TO MAINS TRANSFORMER

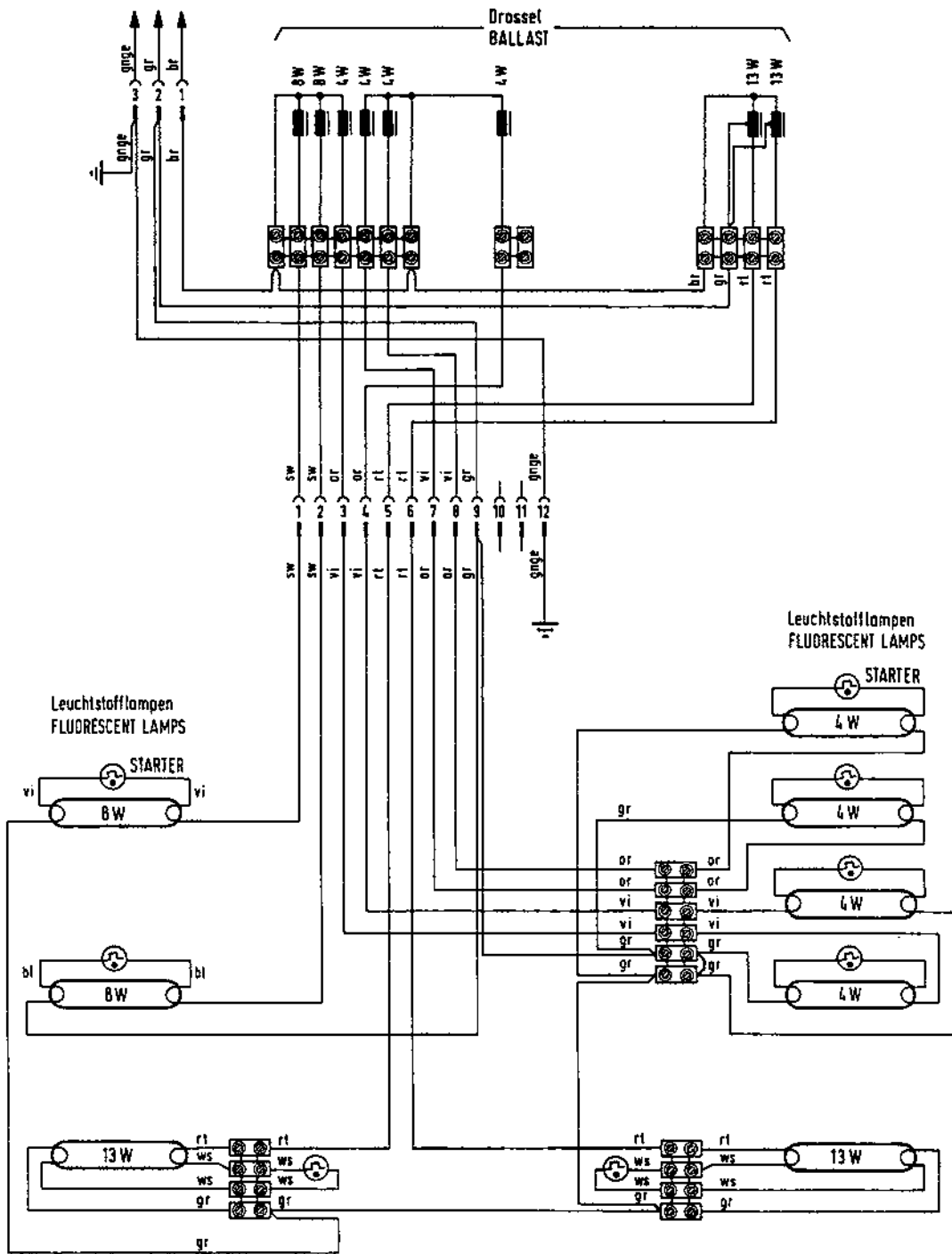

Farb Spiegel
COLOR CODE

ws	weiß	white
bl	blau	blue
br	braun	brown
ge	gelb	yellow
gn	grün	green
gr	grau	grey
or	orange	orange
rs	rosa	pink
rt	rot	red
sw	schwarz	black
vi	violett	violet

Farbangaben ohne Gewähr.
COLOR INDICATION WITHOUT WARRANTY.

ÄNDERUNGEN IM SINNE DES TECHN. FORTSCHRITTES VORBEHALTEN,
JEDOCH KEINE NACHRÜSTPFLICHT!

SUBJECT TO TECHNICAL MODIFICATION WITHOUT OBLIGATION
TO MODIFY EQUIPMENT ALREADY DELIVERED!

NSM MUSIKAUTOMATEN ES V-CD TECHNOLOGY
PHONOGRAPHES

Schaltbild Beleuchtung [60 HZ]
WIRING DIAGRAM ILLUMINATION

THE WIZARD

Dat. 26.06.92 Gez. Braun Bearb. *Wolfgang Braun*

Zum Netz-Transformator
TO MAINS TRANSFORMER

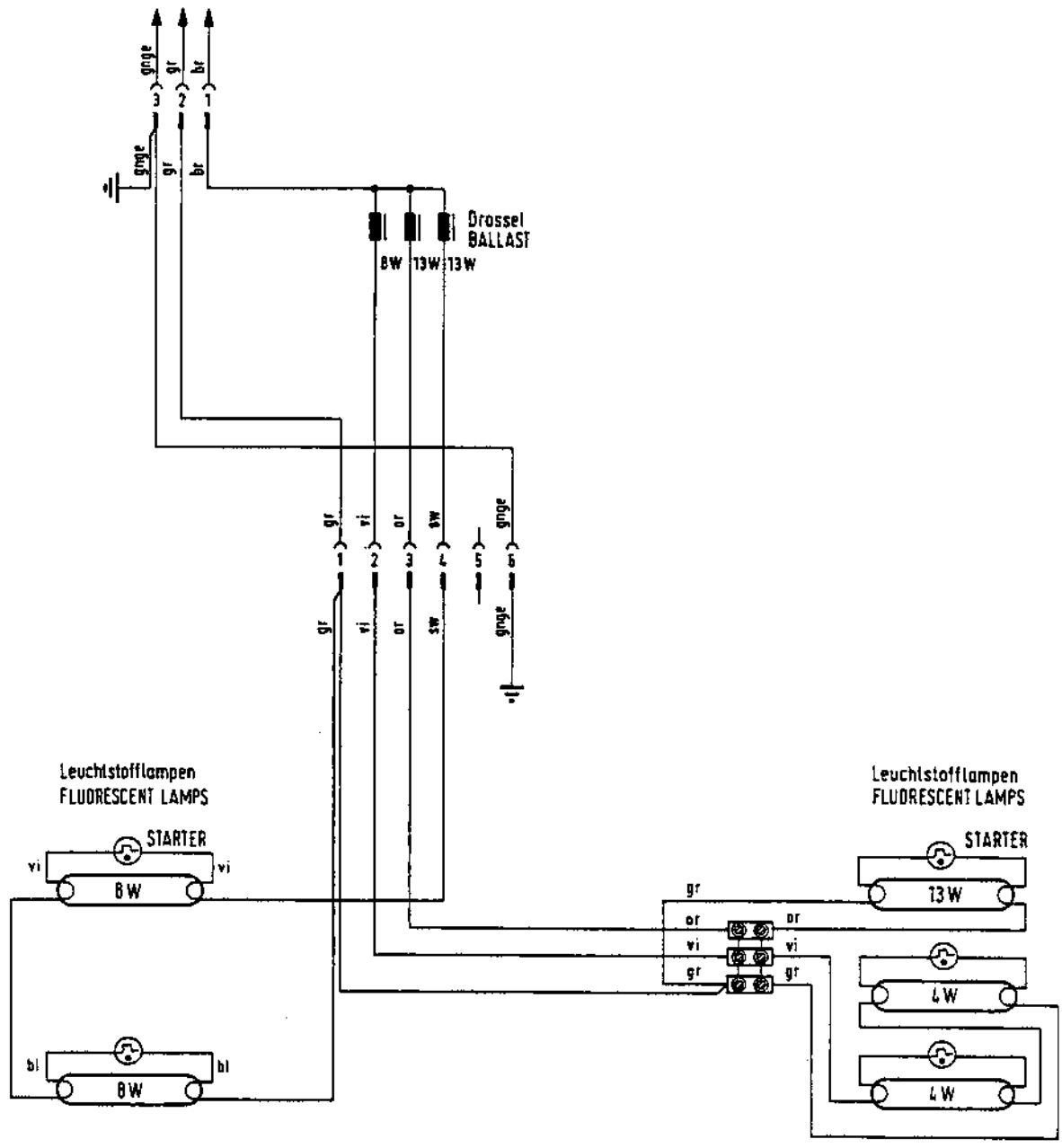

Farbangaben ohne Gewähr.
COLOR INDICATION WITHOUT WARRANTY.

ÄNDERUNGEN IM SINNE DES TECHN. FORTSCHRITTES VORBEHALTEN,
JEDOCH KEINE NACHRÜSTPFLICHT!

SUBJECT TO TECHNICAL MODIFICATION WITHOUT OBLIGATION
TO MODIFY EQUIPMENT ALREADY DELIVERED!

Farb Spiegel
COLOR CODE

ws	weiß	white
bl	blau	blue
br	braun	brown
ge	gelb	yellow
gn	grün	green
gr	grau	grey
or	orange	orange
rs	rosa	pink
rt	rot	red
sw	schwarz	black
vi	violett	violet

NSM MUSIKAUTOMATEN PRONOGRAPHS **ES V-CD** TECHNOLOGY
Schaltbild Beleuchtung [50 HZ]
WIRING DIAGRAM ILLUMINATION



Dat	26.06.92	Gez	Braun	Gepr	<i>[Signature]</i>	Gepr	<i>[Signature]</i>
-----	----------	-----	-------	------	--------------------	------	--------------------

Zum Netz-Transformator
TO MAINS TRANSFORMER

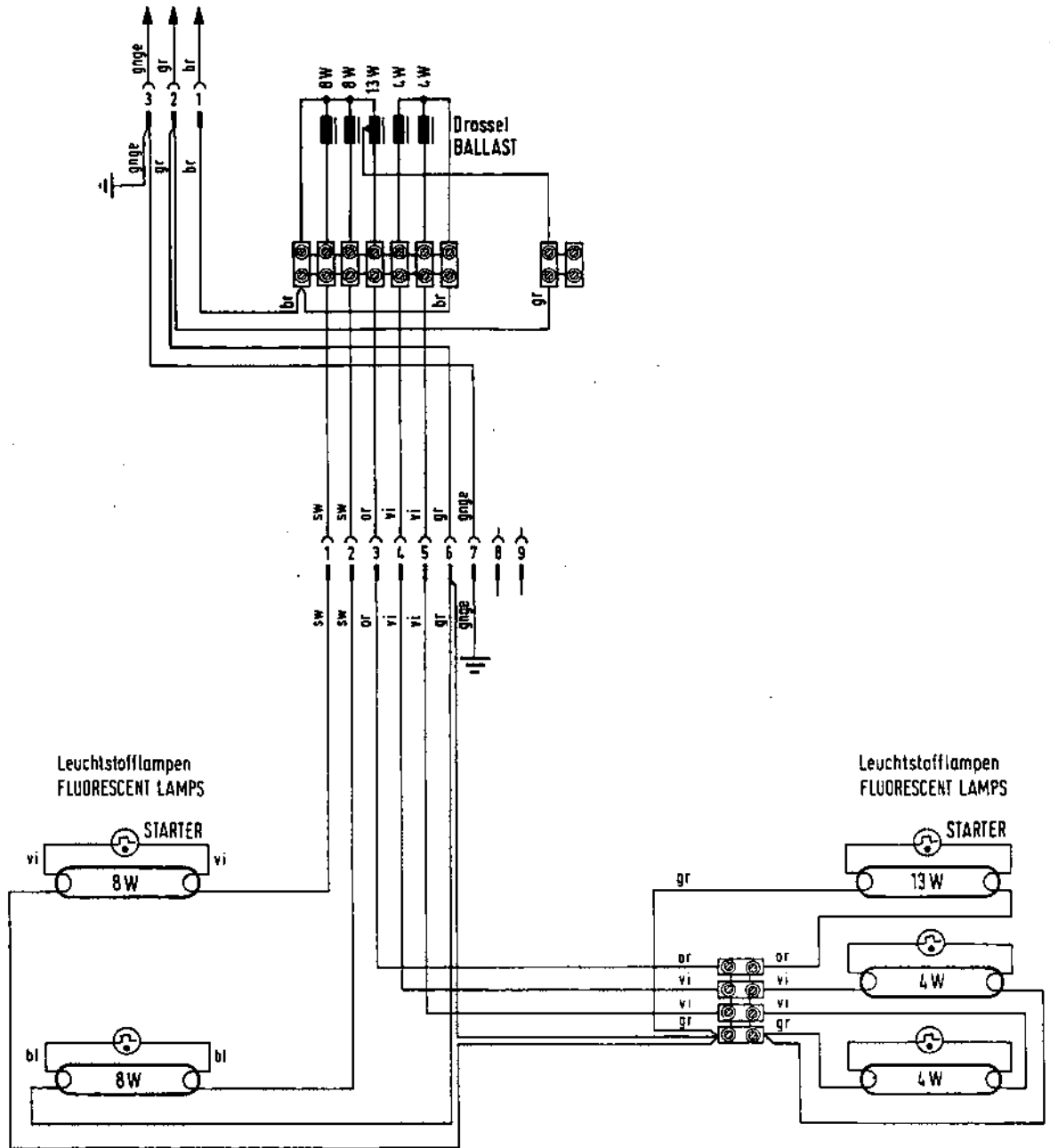

Farbangaben ohne Gewähr
COLOR INDICATION WITHOUT WARRANTY.

ÄNDERUNGEN IM SINNE DES TECHN. FORTSCHRITTES VORBEHALTEN,
JEDOCH KEINE NACHRÜSTPFLICHT!

SUBJECT TO TECHNICAL MODIFICATION WITHOUT OBLIGATION
TO MODIFY EQUIPMENT ALREADY DELIVERED!

Farb Spiegel
COLOR CODE

ws	weiß	white
bl	blau	blue
br	braun	brown
ge	gelb	yellow
gn	grün	green
gr	grau	grey
or	orange	orange
rs	rosa	pink
rt	rot	red
sw	schwarz	black
vi	violett	violet

NSM MUSIKAUTOMATEN **ES V-CD** TECHNOLOGY
PHONOGRAPHS

Schaltbild Beleuchtung [60 HZ]
WIRING DIAGRAM ILLUMINATION

WIZARD

Dat 26.06.92 Gez Braun Bearb. [Signature] Gepr. [Signature]

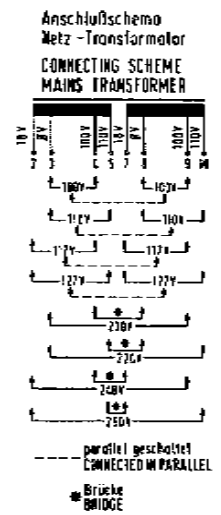
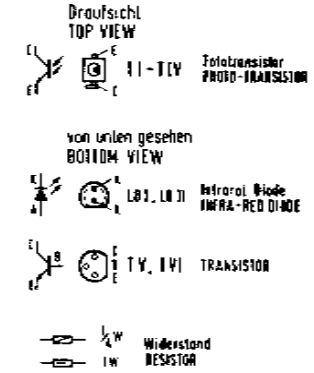
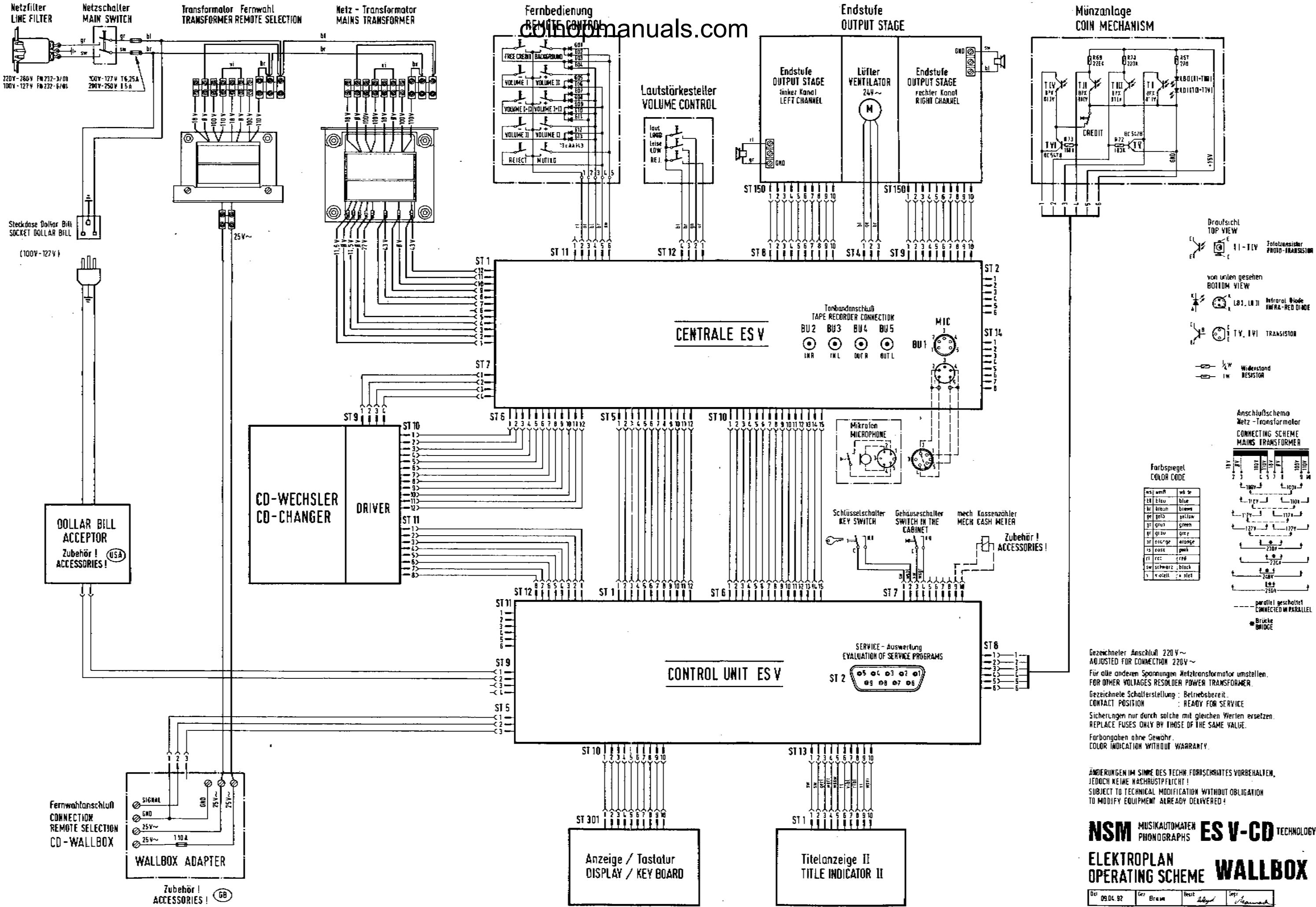

Gezeichneter Anschluß 220V ~
ADJUSTED FOR CONNECTION 220V ~

Für alle anderen Spannungen Netztransformator umstellen.
FOR OTHER VOLTAGES RESOLDER POWER TRANSFORMER.

Gezeichnete Schalterstellung: Betriebsbereit.
CONTACT POSITION: READY FOR SERVICE

Sicherungen nur durch solche mit gleichen Werten ersetzen.
REPLACE FUSES ONLY BY THOSE OF THE SAME VALUE.

Farbangaben ohne Gewähr.
COLOR INDICATION WITHOUT WARRANTY.

ÄNDERUNGEN IM SINNE DES TECHN. FORTSCHRITTES VORBEHALTEN,
JEDOCH KEINE NACHRUFPLICHT!
SUBJECT TO TECHNICAL MODIFICATION WITHOUT OBLIGATION
TO MODIFY EQUIPMENT ALREADY DELIVERED!

NSM MUSIKAUTOMATEN ES V-CD TECHNOLOGY PHONOGRAPHS

ELEKTROPLAN OPERATING SCHEME WALLBOX

Druck 09.04.92, Zeichner Braun, Best. 141, Fertiger Schmidt

OPERATING INSTRUCTIONS FOR NSM-PHONOGRAPHS

ES V-CD TECHNOLOGY

to
Technical Information, Assy

176 393	THE PERFORMER GRAND II
176 352	THE WIZARD / OLD FASHION WIZARD
176 514	THE PERFORMER CLASSIC
176 610	CD HIDE-AWAY II
176 598	FIREBIRD II

NSM

Aktiengesellschaft
Saarlandstraße 240
6530 Bingen am Rhein

2

Page 201-211

INDEX

- 1 PLAYING SEQUENCE**
 - 1.1 Operation after switching on**
 - 1.2 Standby**
 - 1.3 Credits**
 - 1.4 Title display**
 - 1.5 Selection**
 - 1.6 Play mode**
 - 1.7 Advertising**
 - 1.8 Lock out titles**
 - 1.9 Service and Maintenance**

- 2 ADJUSTMENTS WITH REMOTE CONTROL**
 - 2.1 Volume controls**
 - 2.2 Muting**
 - 2.3 Free credits**
 - 2.4 Background music**
 - 2.5 Key switch**

- 3 PROGRAMMING OF PRICE- AND MONETARY VALUE SETTINGS**

- 4 CD CHANGE / CASH COLLECTION**

SELECTOR and DISPLAY PANEL

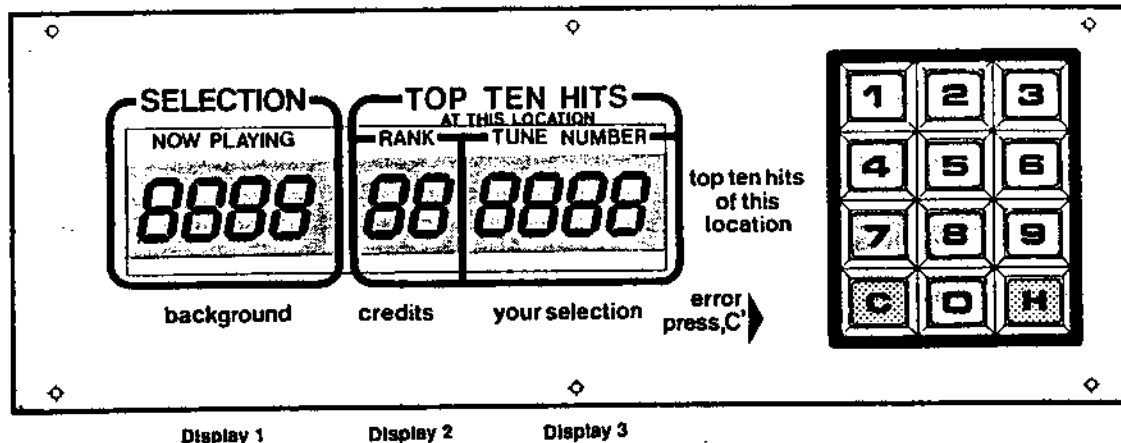

1 PLAYING SEQUENCE

The functional sequence, starting with "power on", standby credit, selection and playing of selected title to the rest position is described below.

The technical assembly and the working together of the components can be seen in the "electronic schematics". Compare the descriptions with the illustration of the display / keyboard above.

1.1 Operation after Switching on

Immediately after switch-on the memory components -on the CONTROL UNIT- and all preprogrammed values are checked.

Display 1 shows then for 2 sec. the program index

If an error is found during checking, error display Er xx is then shown for 2 sec.

With Er 31 (unverified memory contents) and Er 40 (price settings incorrect) Display 1 shows the correct program step with Pxxx which needs to be reprogrammed. See programming manual.

With other Er-numbers in display 3, even during operation, proceed according to the instructions in "Trouble Shooting".

1.2 Standby

Hit display:

The microprocessor of the CONTROL UNIT finds out the ten most played titles of the 30 titles just played before (at this phonograph).

On Display 3 the title numbers of the 10 most popular titles, whose rankings (1-10) are shown on Display 2, are changed in intervals of 2 sec. Also the lamp "top ten hits" lights up.

When pushing "H", the hit display can be stopped for 16 sec; every press the key "H" causes an advance to the next hit.

Note: When the popularity counters are erased (program step P033), the hit parade is erased too. In that case "0" appears for ranking until records are played again.

Autoplay mode:

A time interval can be set by programming the command group P 11x for playing of incentive titles.

Conditions for an incentive title to be played:

- Phonograph in standby mode
- No credit available
- Microphone switch not being used
- No muting

1.3 Credits (not for HIDE-AWAY)

See unit description "Coin and Bill Validation".

After insertion of a coin the hit display is interrupted, lamp "10 top hits" goes off and lamps "credit" and "your selection" light up. Display 2 shows the number of credits.

For every selection credit is deducted.

If not enough credits are available for the selection, the lamp "credit" flashes.

If no more coins are inserted within 16 sec. or no selector key is pressed, the mode changes to "hit display".

Free-credit switch (add. key), below the mechanical coin acceptor or on the adapter PCB with electronic coin validators, is only possible when the cabinet lid is open and the cabinet interlock switch is in service position (press add. button once = 1 credit). These credits are not registered statistically.

Attention! The machine is furnished with an interlock switch which must be manually set in service position (pull out). The switch resets automatically when closing the lid.

Note: Credits remain stored during "power off/on" (P049 = 0).

If the computer detects no activity on the phonograph within a time, the stored credit is cancelled (P049 = time).

1.4 Title display

By pushing the keys respectively title holders are moved into the corresponding direction. Upon each key operation two new CD-covers including titlestrips are shown. In case of a limitation of selectable CDs by programming P042 only the corresponding title holders are shown.

Note: A problem with the title display will initiate error code "Er 9x". Following instructions in "Trouble Shooting".

1.5 Selection

Title Selection: The four-digit number of the desired title has to be entered (2 digits each for disc and track). "Credit" and "your selection" light up. The selection can be corrected by pressing "C" up to 2 sec. after pressing the 4th digit.

Album Selection: When entering Track 00, all titles of a CD are automatically played (i.e. 0100 = all titles of Disc 01).

With open cabinet switch (interlock lever pulled out) no credit is deducted when selecting.

If the entry is incorrect, e.g. higher than the programmed number of CD tracks which can be selected or an unallowed selection of albums, "error" flashes. In that case, press "C" and repeat the selection. One credit is deducted for each selection of a title. With album selections credits are deducted as per the programming in program step P066. When programming "0", album selection is blocked. If there is not enough credit available, "credit" lamp flashes.

16 sec. after selection "hit display" is switched on automatically again.

Note: If a background or incentive title is playing during selection, the volume is fading and the selected tune is being played.

When selecting a higher title number than recorded on the CD, the first title (track) of the CD will be played automatically.

1.6 Play Mode

After selection of a title the CD which is to be played corresponding to the entries in the selection storage is transported to the player and then played.

Just before start the number of the title is shown on Display 1 ("selection now playing"). After the disc is played, the display is erased and the CD is transported back to its magazine space.

Note: If a error occurs with the CD changer or the player, "Er 7x" or "Er 6x" appears for 2 sec. In that case proceed according to the description in "Trouble Shooting".

Limiting playing time for a title (track)

By programming P045 the time that a title is to be played maximum can be set in minutes.

After expiration of this time the volume for that title is fading and then muted.

When setting "0" (default), there is no limit in playing time.

Sequence of tunes playing

By programming P046 one can set in which sequence the selected titles are played.

Settings: 0 = in sequence of selection (FIFO)
 1 = in numerically increasing sequence
 2 = random sequence

Limit of Playing Titles on the same CD

One can set by programming P047 how many titles can be played consecutively on the same CD.

With 0 (default) there is no limit.

Attention!

When playing a test compact disc, the description that comes with the test disc is to be exactly adhered to. By any means, it is to be avoided to give sine signals with peak signal "0dB" at full volume level to the loudspeakers for more than 1 sec.

But also other unfiltered noises and high-frequency signals (which are only used for measuring purposes) can damage the amplifier and loudspeakers at full volume.

When checking channel separation, it is to take in consideration if the box is not switch to "Mono-mode" (see page 110).

1.7. Advertising

With the commands of group 12x it is possible to define timeslices for playing special CD's containing advertising information (ad).

While the ad-mode is active a title is played every x minutes (x ist the time defined in P124) after closing the currently played title. The CD's containing ad can be selected for "not to be played by normal customers" (P126).

1.8 LOCK-OUT TITLES

If one titles of a CD is bad it can be locked out for a defined time at every day by programming the steps in group P13x.

A lock out title can be defined by

- bad quality of reproduction
- bad track within the title
- shocking information.

But also to favour other not so often played titles you can lock out e.g. the top ten hits.

1.9 SERVICE and MAINTENANCE

With the commands of groups 15x and 16x you can

- read out errors of the phonograph with CD and date of appearance,
- test the CD changer,
- test the CD played,
- test the lamps and keys,
- install new CDs
- remove bad or not actual CDs.

Refer to "Programming of the phonograph" and "Trouble shooting"

2 ADJUSTMENTS WITH REMOTE CONTROL

The phonograph can optionally be equipped with cable-type remote control or infra-red remote control. All functions and the operation of both models are identical. Therefore, this description is valid for both of them.

The button-control box attached to the rear of the cabinet allows common control of both channels "+" or "-" and "REJECT".

Information about the functions of different controls is presented in the unit description "Remote Control".

2.1 Volume Controls

We differentiate between two volumes:

- 1.) The normal volume of selected titles and random play titles
- 2.) The background volume of background titles

For selected titles and random titles or with microphone and tape mode the corresponding volume is adjustable; background volume only with background mode:

Key "I" for the left channel; Key "II" for the right channel; "+" = louder, "-" = quieter. When pushing center key (I+II), the channels are regulated together. If they were differently set, they are first "balanced" and regulated together.

When no selection is taking place, the volume for the channels are shown in Display 3 during the adjustment in steps of "1" to "31".

At "muting" function "OFF" appears in Display 1; no more titles will be played until MUTING is cancelled.

The volume set at the end is stored during "power off".

The maximum possible volume for normal and background mode can be limited By programming P051 in steps of "1" to "31", and P052 in steps of "1" to "16".

Note: To protect the amplifiers a check is made whether an overload occurs due to mismatching in 250 ms cycles.

Upon recognition of an error the volume of the corresponding channel is reduced step by step automatically by the computer until a non-critical point is reached.

2.2 Muting

The volume of both channels can be set to "0" by pressing the MUTING key; "OFF" appears on Display 1. Re-pressing of the MUTING key or one of the VOLUME "+" keys causes the system to switch back to the previously set volume for both channels.

Note: With display "OFF" no more records are played until MUTING is switched off.

2.3 Free Credits

With an "open" key switch free credits programmed in program step P094 can be called up. The following free credits are possible depending upon the settings in step P094:

- 1.) Number of set free credits can be called up individually step by step.
- 2.) Unlimited free credits can be called up individually step by step.
- 3.) Permanent credit when pressing key "FREE CREDIT" for the first time (credit display "99"). When key "FREE CREDIT" is pressed again, permanent credit is blocked.

2.4 Background Music

With an "open" key switch the background mode can be switched on with the BACKGROUND key. "Background playing" lights up.

When pressing this key again, the background mode is switched off. In the background mode "random" records are played as defined in P105. The time when background musik is played is to set in P10x.

The records are played at a "specific" background volume which can be changed as desired during playing.

A "normal record", selected while background music is playing, interrupts the background disc and the selected tune is played at "normal volume".

2.5 Key Switch

A key switch at the side wall serves as protection against unauthorized calling up of free credits and switching on the background mode. When the key switch is "locked", settings from the remote control are disregarded. Key switch "open" permits programmed free credits to be called up and the background mode to be switched on.

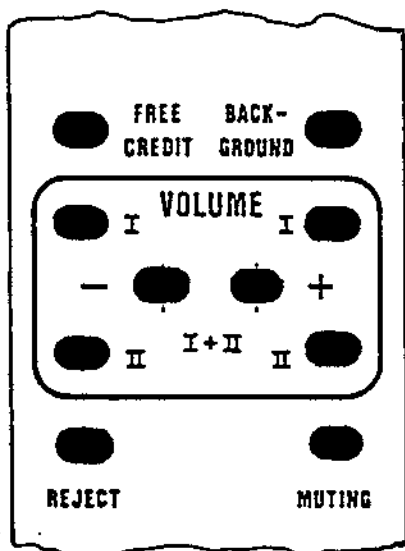

REMOTE CONTROL

3 PROGRAMMING PRICE- AND MONETARY VALUE SETTINGS

This description is a summary of a section of the service program.

A detailed description and the corresponding tables are contained in chapter "Price Settings" and "Monetary Value Settings" in the programming manual.

Practical example for setting the "price settings" and the "monetary value settings":

1 play = 30 p
 2 plays = 50 p
 5 plays = 1 £

Programming of price settings:

Programming Information	Operation	Displays		
		1	2	3
Switch-over from play mode to service mode	pull out plunger	P010	xx	xxx
	Press key(s)		SP:	GW:
Entering command mode	"C"	P		
Direct selection of a command, Display of previous setting in P061.	"61", "H".	P061	xx	xxx
New setting in P061 "1 play/30 p".	"01", "02", "H".	P061	01	030
Advance to next command, Display of previous setting in P062.	"H"	P062	xx	xxx
New setting in P062 "2 plays/50p".	"02", "050", "H".	P062	02	050
Advance to next command, Display of previous setting in P063.	"H"	P063	xx	xxx
New setting in P063 "5 plays/1 £".	"05", "100", "H".	P063	05	100
Advance to next command, Display of previous setting in P064.	"H"	P064	xx	xxx
For only 3 classes setting "00 000".	"00", "000", "H".	P064	00	000
Advance to next command, Display of previous setting in P065.	"H"	P065	xx	xxx
For only 3 price classes setting "00 000"	"00", "000", "H".	P065	00	000

Caution! Press "C" key in the event of incorrect programming or when display flashes.

Press "C" key twice or close hood to return to standard program (play mode).

Example of Programming the monetary value settings:

The individual coin channels must be programmed for the associated monetary values in the corresponding program steps: Channel 1 for 20 pence in program step P071, channel 2 for 50 pence in program step P072, channel 3 for 10 pence in program step P073. Channel 4 (P074) and channel 5 (P075) are not used; both must be programmed with the monetary value "0".

Checking the monetary value settings: Select one program step between P071 and P075. After inserting a certain coin the channel associated with the coin is displayed, e.g. 50 pence in channel 2: Display P072 050.

Changing the monetary settings: As an example, the 20 pence slot (channel 1) is not to be used: First enter program step P071 as described above. In the coin acceptor or on the adapter PCB of electronic coin validators the respective channel has to be blocked also so that these coins drop into the coin return.

Standard settings: The programming of standard settings is done with the command P070 and entering the number of the desired table values (see table "Monetary value settings" in the chapter "Programming of the phonograph"). The correct programming of all channels is done automatically after entering the number and pressing the key "H".

Programming information	Press keys	Displays		
		1	2	3
Direct selection of a command, Display of previous setting in P071.	See text.	P071		xxx
New setting; no coin conversion	"000", "H".	P071		000

If the standard setting according to the table is to be used thereafter, call up program step P070 (as described previously).

Ready for standard setting P071 through P075	See text.	P070		
Program standard table 1.	"1", "H".	P070		1

Press "C" key twice or close cabinet hood and return to standard program (play mode).

4 CD CHANGE / CASH COLLECTION

- Open machine and activate cabinet switch (pull out plunger) to enter into service mode. Display 3 automatically shows the least played CD.
- By pressing "1" successively, the next best CD is shown each time.
- Unlock magazine, swing out; pull out the corresponding CD holders to change CD's. After changing push back CD holders until they lock in.
- Change corresponding title cards, unlock flip-chart unit and flap down. Get desired program tables in position with the button on the PCB of the right-hand side of the unit.
- Read counters:
 - P013 = Cash total
 - P016 = Counter for plays
 - P017 = Number of selected titles
 - P018 = Number of selected albums
 - P021 = Number of free credits provided
 - P022 = Number of background titles played
- Erase counters: P033, and selected code number.

For more information see chapter "Programming the phonograph."

PROGRAMS FOR NSM-PHONOGRAPHS

ES V-CD TECHNOLOGY

to
Technical Information, Assy

176 393	THE PERFORMER GRAND II
176 352	THE WIZARD / OLD FASHION WIZARD
176 514	THE PERFORMER CLASSIC
176 610	CD HIDE-AWAY II
176 598	FIREBIRD II

NSM
Aktiengesellschaft
Saarlandstraße 240
6530 Bingen am Rhein

3

Page 301-325

Main Menu	303
Programming Table for NSM Phonographs	304
1. Authorization of P001 to P002	305
2. Statistics P010 to P025	305
3. Data Transfer/Cancellation! P030 to P033	308
4. General Settings P040 to P054	310
5. Price Setting P060 to P066	314
6. Monetary Value Setting P070 to P076	315
7. Programming Real Time Clock P080 to P082	317
8. Programming Free Credits P090 to P094	318
9. Programming Background Music P100 to P107	319
10. Programming Auto Play P110 to P117	320
11. Programming Advertising P120 to P127	320
12. Blocking certain titles P130 to P135	320
13. Calling up Test Programs P150 to P164	321
13.1 Test Programs for Service Operation	321
13.2 Recording title quantities in title memory	325

Overview of tables used

Table 1: "Overview Commands of Sercive Program"	303
Table 2: "Price Setting"	314
Table 3: "Monetary Value Setting"	316
Table 4: "Error Codes"	322

PROGRAMMING OF PHONOGRAPHS

Main Menu

In order to program NSM phonographs in a simple yet extensive fashion, a service program has been installed with which the different settings can be altered via the keyboard of the phonograph or the remote control.

In order to get to operating mode "programming", the following steps must be taken:

Opening of cabinet lid (door) and
pulling out service switch (cabinet interlock switch).

By changing the display, the phonograph indicates that it is in operating mode "programming". The display shows the following text:

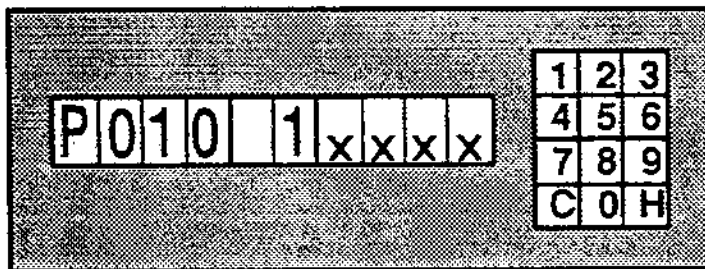

Illustration: "Display after calling up command mode"

The display "popularity" shows the least played CD. When pressing "C", the display is cancelled. To the left the letter "P" appears. Now enter the desired command number. Zeros before the number can be left out. Pressing "H" confirms the entry. In order to find single commands easier, all possible commands are put together in single groups. Compared to their predecessors, the programming of machines with ES-V technology is much more extensive. The commands of Groups 1 to 6 and 13 have previously existed, but have been revised. The commands in Groups 7 to 12 have been added. By integrating a real time clock, the phonograph has been equipped with some very interesting new commands. Thus, the phonographs have become even more attractive.

In Table 1: "Overview Commands of Service Program" the 13 command groups existing now are listed.

Table 1: "Overview: Commands of Service Program"

Group	Name of Command Group	Command Numbers
1	Authorization	P001...P002
2	Statistics	P010...P026
3	Data Transfer/Cancellation	P030...P033
4	General Settings	P040...P054
5	Price Setting	P060...P066
6	Monetary Value Setting	P070...P076
7	Programming Real Time Clock	P080...P082
8	Programming Free Credits	P090...P094
9	Programming Background Music	P100...P107
10	Programming Auto Play	P110...P117
11	Programming Advertising	P120...P127
12	Lock-out of Different Titles	P130...P135
13	Test Programs	P150...P164

The following page lists the commands possible with this service program. When entering the respective command number, one can eliminate the zeros before the number. A command called up in error can be cancelled by pressing "C".

Table of Programs for NSM Phonographs with ES V-Technology

P001	Authorization: Enter code: "PPPP"	P030	Storing data in DATA PRINT 0- cashbox, counters, popularity, errors...	P060*	Price settings: see table "Price settings"	P100*	Program background music: 0+H- default; cancels entries + time	P130*	Lock-out certain titles: 0+H- default; cancels entries + time
P002*	Change authorization code "PPPP"	P031*	Print data on DATA PRINT 0- all available data			P101*	Start time for time window "Background music"	P131*	Start time for time window "Free title selection"
	Statistics:		1- Cashbox 2- Counter with cashbox	P061*	Arbitrary price setting for chute 1 xx-selections, yyyy-price "xx yyyy"	P102*	Stop time for time window "Background music"	P132*	Stop time for time window "Free title selection"
P010	0- No. of least played CD 1- No. of second-least played CD		3- General settings 4- Popularity of all CDs	P062*	ditto for chute 2	P103*	Active on weekday(s) "x" (x = 1 to 7) (0=no, 1=yes)+H	P133*	Active on weekday(s) "x" (x = 1 to 7) (0=no, 1=yes)+H
	2- Number of plays 3- Data about any CD		5- Top 30 hits 6- Previous 20 error reports	P063*	ditto for chute 3	P104*	Lock for background music (BGM): 0- No BGM	P134*	Activate lock: 1- Title locked 0- Title in time window available
P011	0- No. of the most played (best) CD 1- No. of the second-best CD	P032*	Print data on any printer with print-out of all data (Option).	P064*	ditto for chute 4		1- BGM possible in time window 2- BGM automatically in time window	P135*	Entry of 20 titles or albums Enter: nnnn+H
	2- Number of plays 3- Data about any CD	P033*	Cancellation routines! 0+H- Cancels all memories!	P065*	ditto for chute 5	P105*	Entry of 20 titles or albums Enter: nnnn+H		
P012	0- Top-life, Hit #1 1- Second-best title		1+H- Cancels top 30 hits! 2+H- Cancels popularity!	P066*	Bonus listing for album selection 0- No album selection allowed	P106*	Patron Selection (0-free, 1-locked for guests)		CALLING UP TEST PROGRAMS:
P013*	0- Cash amount since last evaluation 1- Accumulated Cashbox amount		3+H- Cancels counters and cashbox! 4+H- Cancels credit!		1- No bonus 2- 1 bonus for 5 Titles	P107*	Sequence of play (0-FIFO, 1-RANDOM)	P150	Read out error report memory: 0- Last reported error
P014*	0- Number of coins through Chute 1 (K1) 1- Number of coins through Chute 2 (K2)		5+H- Cancels all selection memories! 6+H- Cancels all error report memories!		3- 1 bonus for 4 Titles 4- 1 bonus for 3 Titles				1- Previous error report 2- CD-Nr. at which the error occurred
	2- Number of coins through Chute 3 (K3) 3- No. of coins through K4 or bills NP1					P110*	Program auto play: 0+H- default; cancels entries + time		3- Time of occurrence 4- Date of occurrence
	4- Number of bills through validator NP2 5- Accumulated counter for K1	P040*	General settings: 0+H Default values for 41 to 54 and 94	P070*	Monetary value settings: see table "Monetary value settings"	P111*	Start time for time window "Auto Play"	P151	0- Continuous run 1: all CDs played for 16 sec. each
	6- Accumulated counter for K2 7- Accumulated counter for K3		1+H Default values for 41 to 54 and 94 104, 105 and 114, 115, 117		0+H- Cancels previous monetary value n+H- Selection "n" from table (s.a.)	P112*	Stop time for time window "Auto Play"	P152	0- Selected CDs played for 16 sec. each Enter: nnnn+H
	8- Accumulated counter for K4 or NP1 9- Accumulated counter for K6 or NP2	P041*	Define machine code number, maximum 4 digits "0"	P071*	Arbitrary monetary value setting 1. chute 1 zzzz-coin value (0500-\$ 5,-) "zzzz"	P113*	Active on weekday(s) "x" (x = 1 to 7) (0=no, 1=yes)+H	P153	0- Continuous run 3: All CDs are placed in the lift, but not played
P015*)	0- Cash amount of wall box 1- Accumulated Cashbox amount	P042	Selection limit for CD/TRACK (title) max. 100CDs, 99 tracks "0024"	P072*	ditto for chute 2	P114*	Time between two titles in minutes Enter: nn+H (0=no auto play)		1- Continuous run 4: 5 CDs are continual ly played for 16 sec (1,25,50,51,75,00)
P016*	0- Counter of played titles 1- Accumulated counter	P043	Light show in stand-by, if installed "1105"	P073*	ditto for chute 3	P115*	Entry of 20 titles or albums Enter: nnnn+H		2- Continuous run 5: 2x cont. run 3, thereafter repeated cont. run 4
P017*	0- Counter of selected titles 1- Accumulated counter	P044	Light show in operation, if installed "1000"	P074*	ditto for chute 4	P116*	Patron Selection (0-free, 1-locked for guests)	P155	0- Lamp test (F6); Stop with key "C"
P018*	0- Counter of album selections 1- Accumulated counter	P045*	Time limit for play in minutes for one title (0=no limit) "0"	P075*	ditto for chute 5	P117*	Sequence of play (0-FIFO, 1-RANDOM)	P156	0- Input test (F7); Stop with key "C"
P019*	0- Counter of overlay titles 1- Accumulated counter	P046	Sequence of play for normal selections (0/1/2) "0 (FIFO)"	P076*	Bonus credits for bill insert "0"			P157	0- manual control of the CD-changer Stop with key "C"
P020*	0- Counter for paid credits 1- Accumulated counter	P047	Maximum number of titles in a sequence from one CD (0 = no limit) "0"			P120*	Program advertisement play: 0+H- default; cancels entries + time		Stop the continuous runs always with the cabinet switch!
P021*	0- Counter for free credits 1- Accumulated counter	P048	Automatic advancing of title display in minutes (0= none) "0"	P080*	Program real time clock: Set time	P121*	Start time for time window "Advertisement"		Title memory:
P022*	0- Counter for background titles 1- Accumulated counter	P049*	Cancels credits after x/10 hrs. power off (x=0-no, 1 to 240=yes) "2"	P081*	Set date	P122*	Stop time for time window "Advertisement"	P160	0- Read in all CD titles defined under P042 (e.g. initial equipping)
P023*	0- Counter for autoplay titles 1- Accumulated counter	P050*	Cancels selection memory after x/10 hrs. power off (x=0-no, 1 to 240=yes) "2"	P082*	Set weekday	P123*	Active on weekday(s) "x" (x = 1 to 7) (0=no, 1=yes)+H	P161	Read in the titles of one newly equip- ped CD. Enter: CD# "nn"+H
P024*	0- Counter for advertising tracks 1- Accumulated counter	P051*	Maximum volume in play operation (max. 31) "31"			P124*	Time between two titles in minutes Enter: nn+H (0=no adverts)	P162	Read the title memory 0- Number of titles from first CD
P025	Number of unused credits	P052*	Maximum volume for background music (max. 31) "16"	P090*	Program free credits: 0+H- default; cancels entries + time	P125*	Entry of 20 titles or albums Enter: nnnn+H		1- Number of titles from the next CD 2- Number of titles from the last CD
P026	Number of selections not yet played	P053	Set volume "0505"	P091*	Start time for time window "Free Credit"	P126*	Patron Selection (0-free, 1-locked for guests)		3- Number of titles from any CD Enter: CD # "nn"+H
		P054	Set treble and bass "0808"	P092*	Stop time for time window "Free Credit"	P127*	Sequence of play (0-FIFO, 1-RANDOM)	P163	Cancels title memory of one CD upon removal. Enter: CD# "nn"+H
				P093*	Active on weekday(s) "x" (x = 1 to 7) (0=no, 1=yes)+H				
				P094*	Number of free credits: "200"			P164	Switch signal sources: (only necessary when servicing)
					0: No free credits <200: No. of free credits individually used =200: Unlimited use >200: Switch between paid/unlimited use				0+H- Mute (no signal source) 1+H- CD-player 2+H- Tape or cassette player 3+H- Microphone

*) P not yet implemented.

Values = factory settings

1. Authorization of P001 to P002

Because the jukeboxes can be programmed with so many important data as well as input in cash counter and statistics, it is even more important than before that only authorized personnel may have access. For this reason access to essential data of the phonograph can be protected by using an authorization code.

Authorization: In order to call up the protected commands, one must start authorization by using the **P001** command.

Enter: **P 001 H P P P H**

The authorization code "0000" has been programmed for delivery. The phonograph is not protected and the operator can choose his own code by entering command **P002**. For security reasons the code number is not shown. In the display each number is shown as "P". When "PPPP" is shown, the secret code number is complete and after pressing "H" and leaving the programming mode, the machine is protected.

Changing of authorization code: During regular operation changing of the authorization code is only possible after previous authorization. Illegal misuse is thus prevented.

Enter: **P 001 H P P P H** (for authorization)



Enter: **P 002 H p p p p H** (when entering new authorization code)

Caution: As described beforehand, the authorization code is NEVER shown! Therefore, it is important that the code is never lost since there is no opportunity to reprogram the phonograph.

2. Statistics P010 to P026

Within the command group statistics there is information regarding cash and number values as well as statements as to how often CDs are played (popularity, hit parade). The single commands for cash value and counters are divided into two groups. The regular information is under code "0". Cumulated values are under code "1" which have been added up since the jukebox has been operating.

Individual commands:

Popularity: Relating to CD albums, the commands P010 and P011 exist in order to determine the popularity.

- P010:** 0: Display of number of least played CD
- 1: Display of number of the next higher CD (stepping through with "1")
- 2: Number of plays
- 3: Information to any CD (enter CD number)

After entering the proper code, the display shows the information such as the following:

Enter **P 010 H 0** i.e. least played CD No. 45
1



Enter **P 010 H 2** i.e. 13269 plays



Enter **P 010 H 353 H** CD No. 53 in 17th place



- P011:** 0: Display of number of most popular CD
 1: Display of number of next higher CD (advance with "1")
 2: Number of plays
 3: Information regarding any CD (enter CD number).

After entering the proper code, the display shows the respective data.

Enter: P 011 H 0 i.e. most popular CD No. 19
 1



Enter: P 011 H 2 i.e. 731 plays



Enter: P 011 H 3 53 H CD No. 24 in 2nd place



Hit Parade: One can also call up the top 30 titles.

- P012:** 0: Display of top title number, Hit No. 1
 1: Display 2nd best title (advance with "1")

Enter: P 012 H 0
 1 i.e. in 16th place; Title 3 of CD 1



CD title No.

Cashbox: The following commands display the actual cash contents as well as diverse counter readings since the last collection. One receives statistics concerning the entire time of operation by reading the cumulated counters.

The display of the cash amount is done by total numbers, read out in currency amounts?. Contrary to the monetary value setting in command group P07x where the coin value multiplied by factor 100 is displayed, i.e. \$1.-- are entered in P07x as 0100, but are shown as 1 in P013. Display of the cash contents is indicated by maximum 5 spaces (see example).

- P013:** 0: Display of cash contents since the last collection
 1: cumulated cash contents

Enter: P 013 H 0
 1 i.e. \$34,829.-



Coin counter/bill counter: Besides displaying the cash levels, the counters of the individual money chutes can be called up. This makes possible an additional control of the cash contents. The five integrated counters are distributed as follows:

- Chutes 1 to 3: only coins (defined by monetary value setting P071 to P073)
- Chute 4: coins as well as bills (can be selected with P074)
- Chute 5: only bills (defined by P075)

The total of the individual counters corresponds to the total of the cashbox contents.

- P014:** 0: Number of coins through Chute 1 (enter P071)
 1: Number of coins through Chute 2 (enter P072)
 2: Number of coins through Chute 3 (enter P073)
 3: Number of coins through Chute 4 and/or bills counted in Bill Validator 1 (enter P074)
 4: Number of bills counted in Bill Validator 2 (enter P075)

- 5: Cumulated counter Chute 1 (enter P071)
 6: Cumulated counter Chute 2 (enter P072)
 7: Cumulated counter Chute 3 (enter P073)
 8: Cumulated counter Chute 4 (enter P074)
 9: Cumulated counter Chute 5 (enter P075)

Enter: P 014 H 0
 1 i.e. 12,543 coins through
 2 Chute 2
 .
 .
 9



The respective cashbox total is derived by multiplying: number of coins x monetary value of coin.

P015: The command to display the cashbox total has not been implemented yet with remote control wallboxes.

Counter readings: With commands P016 to P024 diverse counters can be called up which can be used as actual counters and as cumulative ones as the commands described previously. The statistical data contained therein can be used to settle accounts.

- P016:** 0: Number of titles played
 1: Cumulated counter
P017: 0: Number of titles chosen
 1: Cumulated counter
P018: 0: Number of albums chosen
 1: Cumulated counter
P019: 0: Number of overplay titles
 1: Cumulated counter
P020: 0: Number of credits paid
 1: Cumulated counter
P021: 0: Number of free credits
 1: Cumulated counter
P022: 0: Number of background titles
 1: Cumulated counter
P023: 0: Number of titles in auto play mode
 1: Cumulated counter
P024: 0: Number of advertising titles
 1: Cumulated counter

i.e. calling up number of titles played; a total of 10273 titles were played on this jukebox.

Enter: P 016 H 1 i.e. 10,273 titles played in total



Further interesting data are recorded in counters P025 and P026.

P025: Number of credits unused.

P026: Number of chosen unplayed titles

3. Data Transfer/Cancellation! P030 to P033

In this group of service program commands the stored data in the counters mentioned beforehand are prepared for output to a DATA PRINT or to evaluation devices which process the data. Prerequisite is, for instance, the DATA PRINT is already connected to the evaluation connector (ST2 on the control unit). After calling up the command and entering the respective code, data transfer follows. If an error is determined, "EO" is shown in Display 3. In that case, please check the connection to DATA PRINT. "EO" is also shown, if the print command was not issued within 1 minute after plugging in. In that case, the reset key on the printer has to be pressed again.

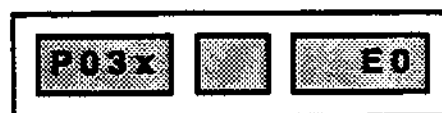

DATA PRINT:

P030: 0: All data of the statistics counters are processed and sent to DATA PRINT. There they are stored and printed out depending on DATA PRINT setting.

The stored data can continue to be processed by a PC, i.e. by DATA CONTACT.

DATA PRINT Print-out In Graphic Mode:

Contrary to the output of P030, the entire statistics as well as individual statistical areas can be printed out by P031.

- P031:** 0: Print all data
 1: Cashbox amount
 2: Counter with cashbox
 3: General settings
 4: Popularity of all CDs
 5: Hit parade of the best 30 titles
 6: The last 20 errors shown

Enter: P 031 H 0
 1
 .
 .
 6



Any Printer:

Besides using DATA PRINT, any printer can be used.

P032: 0: This command enables the entire statistics print-out on any other printer (optional).

Information regarding interface conditions is available.

CANCELLATION:

The P30 group contains not only the printing commands but also the cancellation commands of counters P010 to P024.

Only the "regular" counters are cancelled. The cumulated counters are excluded from cancellation. The memories for credit and selection of titles as well as the error memory are cancelled.

To avoid the cancellation of data by accident or by unauthorized persons, this function can be protected by an authorization code (enter P001).

P033: 0+H: Cancellation of all memory contents !!CAUTION!!

1+h: Cancels hit parade (P012)

2+h: Cancels popularity (P010)

3+h: Cancels counters and cashbox contents (P013-P024)

4+h: Cancels credit memory

5+h: Cancels selection memory

6+h: Cancels error memory

To additionally safeguard accidental cancellations, each input has to be confirmed by pressing "H".

Enter: P 033 H 0 H
1 1 H
 2 H i.e. cancel popularity
 .
 6 H



4. General Settings P040 to P054

In order to adjust each phonograph individually to the location requirements, certain general settings can be individually changed. Basis are detailed values which have been set at the factory (Note: "default values").

P040: 0+H:programming of default values (P041 to P054, P094),
cancellation of values (P091 to P135)

1+H:as before, additional programming of default values
background music and auto play

P104:	1	P114:	15
P105:	0000	P115:	0100
	9900		2500
	9800		5000
	9700		5100
	9500		7500

Enter: P 040 H 0 H



P041: I.D. Number; every phonograph can be programmed with its own I.D. number. Data print-outs can then be easily identified when several machines are evaluated. The I.D. number has at most 4 digits.

Enter: P 041 H nnnn H



P042: Maximum number of selectable CDs and titles; in partially equipped phonographs, unused magazine slots can be excluded. A maximum of 100 CDs (01-to 00) as well as a maximum of 99 titles can thus be selected. (Default value: 24).

Enter: P 042 H 0024 H
i.e. release 100 CDs with
24 titles ea. to be selected

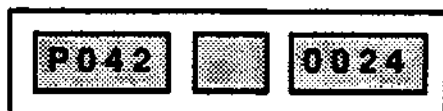

Please remember that each change regarding the number of CDs, the new parameters will have to be reported to the system CPU via program step P16x. Otherwise, there will be problems when playing the CD.

P043: Light in stand-by; a light generator can be programmed, hich causes the phonograph to attract the patrons' attention as long as no music has been selected. **OPTION!**

Enter: P 043 H

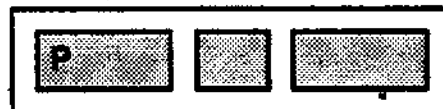

P044: Light during play; another light generator can be programmed here to differentiate between the two. OPTIONI

Enter: P 044 H

P		
---	--	--

P045: Limit play time of one track in minutes; in order to suppress the not so interesting track endings, play time can be limited. The title just playing will slowly fade when the time is up. When entering 0, there is no limit.

Enter: P 045 H 0 H

P045		0
------	--	---

3 H: titles will slowly fade after 3 min.

P046: Sequence of plays at normal selection: in order to alter the music menu, three variations can be chosen when playing different titles:

- 0 - play as selected (FIFO)
- 1 - play in numerically ascending numbers
- 2 - play randomly (RANDOM).

Enter: P 046 H 2 H

P046		2
------	--	---

P047: Maximum number of titles of one CD in sequence; here it is determined how many titles of one CD are played in sequence. 0 means no limit.

Enter: P 047 H 0 H

P047		0
------	--	---

P048: Automatic advancing of title display; 0 = no automatic advancing. If minutes are entered here, the title display is changed accordingly in stand-by.

Enter: P 048 H 10 H, i.e. advancing of title display every 10 min.

P048		10
------	--	----

P049: Cancel credit after X/10 hrs. (X x 6 min.) power off.

P050: Cancel selection memory after X/10 hrs. (X x 6 min.) power off.

Value "X" can be between 0 and 240 with commands P049 and P050.

- i.e. X = 1: waiting time = 6 min.
 X = 10: waiting time = 1 hr.
 X = 240: waiting time = 24 hrs.

"0" does not cancel.

Enter: P 048 H 2 H
 i.e. cancel credit after 12 min.
 power off (2/10 hrs.)



Enter: P 050 H 4 H



Maximum Volume Levels

Maximum volume levels during play and background mode can be pre-set to a certain limit. The manually adjustable volume level of the phonograph cannot go beyond the set levels.

P051: Maximum volume during play; can be set between 0 (mute) and 31 (loud).

P052: Maximum volume during background mode; can be set between 0 (mute) and 16 (loud).

Enter: P 051 H 31 H
 i.e. maximum volume possible



Volume set during Play

P053: Adjustable volume; this function can be set in two ways:
 In the program mode it can be set via the keypad of the phonograph or the remote control, but in regular play mode it can only occur via remote control. In both cases one hears the volume changes. See keypad layout below.

Enter: P 053 H
 Change per pressing keys
 i.e. Key "2" = louder
 Key "8" = quieter



P054: Sound setting (from 1 to 10); here treble (H) and bass volume (B) are set for both channels at the same time. The changed setting can also be immediately heard. See keypad layout below:

Enter: P 054 H

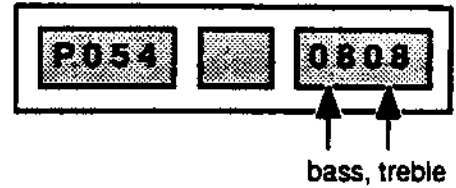

Volume setting

1 ▲ left channel louder	2 ▲ both channels louder	3 ▲ right channel louder
4	5	6
7 ▼ left channel quieter	8 ▼ both channels quieter	9 ▼ right channel quieter
C	0	H

Sound setting

1 ▲ more bass	2 ▲ more treble + bass	3 ▲ more treble
4 mean value	5 mean value	6 mean value
7 ▼ less bass	8 ▼ less treble + bass	9 ▼ less treble
C	0	H

5. Price Settings P060 to P066

To make programming of credit values easier and faster, a table for price settings, standard value via code number, has been programmed for command **P060** in which actual basic values have been entered. The programming of the five possible price levels can be authorized with the table. Another possibility is the individual programming of the individual price scales with commands **P061** to **P065**. Entry as per form plays/monetary value: nn xxxx (nn = two-digit number of plays, xxxx = 4-digit monetary value).

Table 2: "Price Setting"

Table No.	COUNTRY	P061	P062	P063	P064	P065	Remarks
0	_____	00 0000	00 0000	00 0000	00 0000	00 0000	no coin conversion in this setting
1	Germany	01 0100	01 0100	03 0200	03 0200	03 0200	1 play = 1,-DM
2	Belgium	02 2000	02 2000	02 2000	06 5000	06 5000	
3	Netherland	02 0100	02 0100	02 0100	06 0250	06 0250	2 different settings
4	France	02 0500	02 0500	10 1000	10 1000	10 1000	
5	Switzerland	02 0100	02 0100	05 0200	05 0200	14 0500	
6	Austria	01 0500	01 0500	03 1000	03 1000	07 2000	
7	Italy	01 0400	01 0400	01 0400	03 1000	03 1000	
8	Spain	01 0050	01 0050	02 0100	02 0100	05 0200	
9	Greece	01 2000	01 2000	01 2000	02 5000	02 5000	
10	Jugoslavia	01 0200	01 0200	01 0200	03 0500	03 0500	
11	Denmark	01 0300	01 0300	02 0500	05 1000	12 2000	4 different settings
12	Norway	01 0300	01 0300	02 0500	02 0500	04 1000	
13	Finland	01 0300	01 0300	01 0300	02 0500	02 0500	
14	Sweden	01 0030	01 0030	02 0050	02 0050	02 0050	
15	Ireland	01 0010	01 0010	03 0020	03 0020	10 0050	
16	Great Britain	01 0030	01 0030	02 0050	02 0050	05 0100	
17	USA (1) / Canada	01 0050	01 0050	01 0050	03 0100	03 0100	Dollarbill on channel 5 (P065)
18	USA (2)	01 0050	01 0050	03 0100	03 0100	18 0500	
19	Africa	01 0020	01 0020	03 0050	03 0050	07 0100	
20	Australia	01 0100	01 0100	01 0100	03 0200	03 0200	
21	Netherl. Antillen	01 0400	01 0400	01 0400	01 0400	01 0400	
22	New Zealand	01 0050	01 0050	01 0050	01 0050	01 0050	
23	Venezuela	01 0100	01 0100	03 0200	03 0200	03 0200	

In order to program the respective code number is entered after command **P060** and confirmed with "H". The setting selected is automatically conferred to the respective price scales.

Enter: **P060 H1 H**
i.e. price setting: Germany



The stakes for the individual price scales can also be separately defined. With commands **P061** to **P065** the respective stake can be programmed.
Example: 12 titles for DM 5,- (price scale 3)

Enter: **P063 H 120500 H**

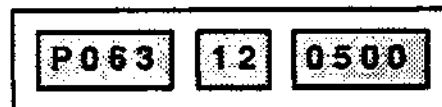

The setting for bonuses with multiple credits (i.e. album selection) is done with command P066 in the service program. The following settings are permitted:

- P066:** 0: no album selection possible
 1: no bonus, default setting
 2: 1 bonus for every 5th track
 3: 1 bonus for every 4th track
 4: 1 bonus for every 3rd track+

Setting is confirmed by pressing "H".

Enter: P066 H 0 H
 1
 .
 .
 4



6. Monetary Value Setting P070 to P076

As with the price setting, the identification of the different coins as related to the monetary values processed by the phonograph, can be done automatically when the pre-defined basic values are sufficient.

Table 3 "Monetary Value Setting" shows which setting can be programmed as basic value (see next page).

The standard values of the table are selected with command P070 "n" + "H" (n = code no. from table).

Enter: P070 H 1 H
 i.e. Germany



"n" is the code number for the respective setting. To avoid erroneous entries, each entry has to be confirmed by "H". This is very important since entry of Code Number 0 cancels the current monetary value setting and no currency acceptance is possible.

As with the price setting, with the monetary value setting the coin value of each chute can be individually identified (P071 to P075).

This is easily done by inserting one or more coins after command P070 has been called up. According to coin value the program changes to the proper chute command P071 to P075. On Display 1 the monetary value of each coin is displayed. This can be changed as needed. Unused chutes have to be programmed with monetary value 0.

Entries occur in the smallest counting unit of each currency that makes sense, i.e.

- with DM 5,- => 0500,
- with ÖS 20,- => 2000, or
- with \$1,- => 0100.

As a rule, though, the standard setting is sufficient.

With command P076 another bonus is defined by paying with bills.

Enter: P076 H 3 H
 i.e. 3 bonuses

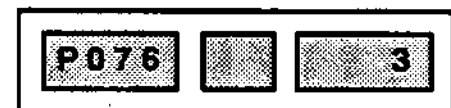

When accepting a bill in Chute 5, this bonus is added to the regular credits.

Table 3 "Monetary Value Setting"

Table No.	COUNTRY	channel 1(P071)	channel 2(P072)	channel 3(P073)	channel 4(P074)	channel 5(P075)	Remarks, example for 1 chan.
0	_____	0	0	0	0	0	no coin conversion
	mechanical coin acceptor						
1	Germany, Switzerland, Venezuela	100	500	200	0	0	100 = 1,-DM 100 = 1 sfr 100 = 1,-Bol
2	Belgium	0	2000	500	0	0	2000 = 20 Bfr
3	Netherlands	25	250	100	0	0	250 = 2,5 hfl
4	Denmark, France	100	500	1000	0	0	100 = 1 dkr
5	Austria	500	2000	1000	0	0	500 = 5 ÖS
6	Italy	200	100	500	0	0	200 = 200 L
7	Spain	0	25	100	0	0	25 = 25 Pst
8	Finland, Norway, Jugoslavia	0	500	100	0	0	500 = 5 mK 500 = 5 Kr 500 = 5 Din
9	Great Britain, Ireland	20	50	10	0	0	20 = 20 p
10	USA	10	50	25	0	100	10 = 10 c, 100 = 1 \$
11	Canada	0	25	0	0	100	25 = 25 c, 100 = 1 \$
12	Union of South-Africa	20	100	50	0	0	20 = 20 c, 100 = 1 R
13	Australia	100	50	20	0	0	100 = 1 \$
14	Netherl. Antillen	0	100	25	0	0	100 = 1 NAF
	elektronic coin acceptor						
15	Germany, Switzerland, Italy	500	100	0	200	0	500 = 5,-DM 500 = 5sfr 500 = 500 L
16	Belgium	5000	500	0	2000	0	100 = 1 Bfr
17	Netherlands	25	250	500	100	0	25 = 25 c, 500 = 5 hfl
18	France	1000	200	100	500	0	1000 = 10 F
19	Denmark, Austria	2000	500	100	1000	0	2000 = 20 dkr 2000 = 20 ÖS
20	Spain	200	50	25	100	0	200 = 200 Pst
21	Greece	0	50	20	0	0	50 = 0,5 Dr
22	Norway	1000	100	0	500	0	1000 = 10 Kr
23	Finland	0	500	100	0	0	200 = 200 L
24	Sweden	500	100	0	100	0	500 = 5 Kr
25	Great Britain	100	20	10	50	0	100 = 1£, 20 = 20 p
26	USA	100	25	0	50	0	100 = 1\$
27	Canada	10	100	25	0	0	10 = 10 c, 100 = 1 \$
28	Australia	0	100	20	200	0	200 = 2 \$
29	Netherl. Antillen	0	0	100	0	0	100 = 1 NAF
30	Neu Zealand	50	10	5	20	0	50 = 50 c

Chutes entered with 0 on this table are blocked. One must be careful to block also the coin pathways so these coins will not be accepted and are rather expelled through the coin return.

7. Programming Real Time Clock P080 to P082

The most important modification of the ES-V technology is the implementation of a real time clock. Referring to the data supplied by the clock, a number of functions have been developed that are dependent on chronological data for start and stop times. Together with the weekday programming which continues to be available, an "automatic program" for a whole week can be developed during which all functions operate automatically.

The real time clock runs quartz-precise with a battery backed-up power supply if the phonograph is turned off.

With command P080 the time can be set. The newly set minute information starts the counter for seconds automatically at zero.

i.e. 10.45 h



The setting occurs via the keypad:

Keypad layout for command:

1	2	3	P080 Set clock	P081 Set date	P082 Set weekday
4	5	6	hours Clock	Day Month	
7	8	9	Minutes	Year	Day code
C	0	H	plus 1	plus 1	plus 1
			Averages or clock reset		
			minus 1	minus 1	minus 1

Day code settings:

1 = Monday	5 = Friday
2 = Tuesday	6 = Saturday
3 = Wednesday	7 = Sunday
4 = Thursday	

With command P081 the date is set according to the illustration and with command P082 the code number for the weekday is entered.

i.e. May 21, 1992

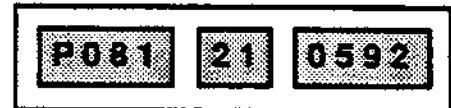

i.e. 4=Thursday

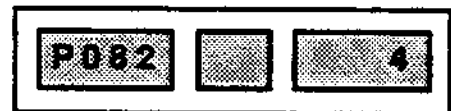

The data supplied by the real time clock are processed by commands P090 to P135 (described as follows) for the so-called time windows. Here the entry of the time window values also occurs via the illustrated keypad layout.

8. Programming Free Credits P090 to P094

The group of 90th commands allows the operator to give free credits (music selection without coin insert) at certain times of the week. Amount and type of free credits are set in the program as well as the time periods.

In P090 a standard setting cancels automatically the previous setting. The time factor is set to zero, so there are no automatic time periods for free credits. "200" entered as default value, meaning an unlimited number of free credits can be called up via remote control. In the free credit display the number "99" will appear.

Enter: P090 H 0 H



P091: To set the starting time for the time window "free credit," the keypad is used.

The keys are defined as in P080 (hours = Keys 1 or 7. Minutes = Keys 3 or 8. 30 min. = Key 6. 12 o'clock = Key 4 and 0000 = Key 5).

Enter: P091 H Setting as per keypad H
i.e. starting time 12:34



P092: Here the stop time of the a.m. time window is set (see P091).

P093: Here the weekday is chosen on which the previously determined time window is to become active.

Enter: P093 H 0 or 1 H



On the middle display the weekdays (according to the illustration of P082) are shown through Numbers 1 to 7. Each weekday can be activated individually. "1" means active on that day. "0" means non-active. The inputs must be confirmed by pressing "H".

If all days are entered at once, then the time window is active for the whole week independent of "0" or "1".

P094: Entering the number of free credits.

These four program types are possible:

- 0: No free credits possible.
- <200: Limited free credit. Amount corresponds to input number. Free credits can be used individually. In the display the remaining credits are shown.
- =200: Unlimited free credit (default setting), can be called up via remote control.
- >200: Switching between paid credits and unlimited free credits possible. Switching via remote control.

Enter: P094 H 200 H



9. Programming Background Music P100 to P107

During those times when few people are present or for social festivities, the phonograph operator can call up the background mode. The played music is heard quietly in the background. This operational mode remains even after a power failure.

If money is inserted into the machine and a title selected, the background music is interrupted for the duration of play.

As a standard this mode is blocked. If command P100 is called up and "0" is entered with "H", the default setting is activated because all settings of Group 10x will be set to 0.

Enter: P100 H 0 H



By defining a time window with P101 and P102 as well as activating it with P103 and P104, the background play is made possible. Three types of operation are possible:

- P104 "0" no background music
- P104 "1" allows starting and stopping background music by pressing background key on machine or on remote control
- P104 "2" automatically plays background music at defined times

What is played as background music, is also determined by the operator. With command P105, followed by 20 four-digit entries, 20 titles or albums can be determined.

They are then played in the sequence selected in P107.

- P107 "0" sequence of play in order of entry (FIFO)
- P107 "1" random play (RANDOM).

Another new function is the "Patron Selection". With command P106 the operator determines whether the selected titles for background music can also be chosen by other customers.

- P106 "0" titles and albums free for selection by "paying guests"
- P106 "1" titles or albums are locked.

10. Programming Auto Play P110 to P117

The phonograph can be programmed to automatically play a title once in awhile to animate the audience during stand-by, the time period when no selections are being made by patrons. The standard setting is "no auto play" since with command P110 "0" + "H" all entries in group 11x are set to 0.

Enter: P110H 0 H



P111 and P112 define the time window and P113 the weekday for auto play. See P091.

With P114 and "nn" + "H" the time between two titles is set in minutes (nn=0:no auto play, nn max=99)

Again, P116 defines the "Patron Selection". See P106.

P117 defines the sequence of play for the titles or albums chosen under P115. See P107.

11. Programming Advertisements P120 to P127

The broad distribution of CDs has led to advertising for various areas being recorded on CDs. Thus, you have another source of income with phonographs with ES-V technology. Standard value is again "no advertising" since with command P120 "0" + "H" all entries of group 12x are cancelled (=0 set).

Enter: P 120 H 0 H



The time window is defined with P121 and P122 and the weekday with P123 for advertisement play. See P091.

With P124 and "nn" + "H" the time in minutes between advertising spots is set. (nn = 0: no advertising, nn max=99).

P126 defines "patron selection" again. See P106.

P127 defines the playing sequence for advertising spots selected with P125 (titles or albums). See P107.

12. Blocking Certain Titles P130 to P135

At certain times it may be necessary to block one or more titles from being played. Perhaps these titles should not be played by minors or are simply damaged (bad playing quality). Contrary to the time windows mentioned beforehand, which allow the respective function when they become active, the function is here lifted when the time window becomes active. Standard is that all titles can be played.

Enter: P 130 H 0 H



With P131 and P132 is the time window and with P133 is the weekday for releasing marked titles or albums defined. With P134 "0" the titles can be selected in the time window; with "1" they are blocked. P135 defines a maximum of 20 titles or albums which are supposed to be blocked. Input occurs with 4 digits for the CD number (nn__) and the title (__nn).

13. Calling up Test Programs P150 to P164

To support the operator when equipping the CD changer with new CDs, trouble-shooting or servicing, several aid functions have been incorporated as known from earlier phonographs. Group 15x of the test programs includes functions such as read-out of error memory, various continuous run tests as well as input and display tests. For these purposes, the respective group code (Fx) is shown in the middle display.

Group 16x serves to integrate the CDs and their title strips in the phonograph memory.

13.1 Test Programs for Service Operation

P150: Read-out of Error Memory:

- 0: last registered error; see Table 4 for "Error Codes" on the next page.
- 1: previous error; the phonograph records the last 20 error reports.
- 2: CD number during which the error occurred.
- 3: Time of error and
- 4: Date of occurrence.

Display:



With commands P151 to P153 various tests in continuous run mode are executed. A continuous run can only be stopped by pressing the cabinet switch.

P151: Plays all CDs for 16 sec. (F1):

- 0: Start continuous run 1

CD/Title Number of Errors



P152: Plays selected CDs for 16 sec. (F2):

- 0: Input of CD number "nnnn" + "H"

During CD play another number "nnnn" can be entered (continuous run 2). With each entry "Your Selection" will light up.

P153: Other Continuous Play Tests (F3 to F5):

- 0: All CDs are placed on player, but are not played (continuous run 3, F3).
- 1: 6 certain CDs (CD No. 1, 25, 50, 51, 75, 00) are placed and played 16 sec. each continually (continuous run 4, F4)
- 2: Combination of twice continuous run 3 followed by 4 until cabinet switch is turned off (continuous run 5, F5).

P155: Lamp Test (F6):

During the lamp test all lamps are successively turned on and off. Pressing "C" stops the test. The lamp test does not check the lamps of a light generator that might be connected.

- 0: Start lamp test
(Display 2 shows briefly F6)



Table 4: "Error Displays"

Displays			Possible Causes	Corrections
1	2	3		
Er	01		EPROM contents (CONTROL UNIT) disturbed.	Change EPROM (IC 2).
Er	10		RAM (CONTROL UNIT) defective.	Change RAM (IC 3). After that reprogram all program steps.
Er	11		RAM contents (CONTROL UNIT) short-term disturbance.	No correction necessary; program is reinitialized. Change RAM IC 3 if frequently occurring.
Er	12		RAM battery is empty.	Change RAM (IC 3). After that reprogram all program steps.
Er	20		Verification errors in program (CONTROL UNIT).	No correction necessary; program is reinitialized. Change CPU IC 1 if frequently occurring.
Pxxx	Er	30	Memory contents (CONTROL UNIT) invalid.	No correction necessary; program step Pxxx (in Display 1) is automatically reprogrammed.
Pxxx	Er	31	Memory contents (CONTROL UNIT) invalid or not programmed.	Program step Pxxx shown in Display 1 must be reprogrammed.
Pxxx	Er	40	Wrong price setting.	Check price setting and, if necessary, reprogram (P060).
Er	50		Coin mechanism defective. Too much credit.	Check coin mechanism.
Er	6x		Error at CD player.	See Er 60 - Er 63.
Er	60		Connection to the CD-player interrupted. No supply voltage present for decoder board or CD player.	Check connection cables to the decoder board, check fuses.
Er	61		No CD recognized by CD player. No CD in CD tray, CD defective. Player defective.	Check CD and exchange if needed. Exchange CD player. Exchange decoder board.
Er	62		Specified track on the CD not found.	Check the CD.
Er	63		Malfunction while playing a CD.	Check the CD player with equipped CD for easy running.
Er	7x		Malfunction on CD changer.	If error display does not disappear after 2 sec., error cannot be automatically corrected. No CD will be played until cabinet switch or "power on" is activated.
Er	70		Malfunction of operating control.	No correction necessary.
Er	71		Error during grip from magazine.	Equip CD-tray to magazine. Check alignment from magazine to pickup assy and adjust if necessary. Check function of light barrier OPPUM.
Er	72		Error during replacing CD in magazine. Malfunction of grip lever.	Check alignment of magazine to pickup assy and adjust if needed. Check function of grip. Check function of light barriers OPGRL and OPGRR.
Er	73		Malfunction during lift drive. Playing of CD not possible.	Check lift for jamming. Check function and correct adjustment of light barrier OPSTP (drive wheel).
Er	74		End position of lift not o.k.. Playing of CD not possible.	Check function and adjustment of light barrier OPEND.
Er	80		Short circuit on wallbox signal wire.	Check wallbox connection.
Er	81		Malfunction of the sound chip.	Change PCB "CENTRALE-CD" if frequently occurring.
Er	90		Title display, three blocking in sequence, not functional anymore.	Blocking remedy.
Er	91		Blocking title display.	
Er	92		Blocking title display.	
Er	93		Blocking title display, stack left.	
Er	94		Blocking title display, stack right.	

P156: Input Test

The input test checks all input ports and shows the results in a matrix on Display 3. The test can be stopped by pressing "C".

0: Start input test (Display 2 shows briefly F7)

Enter: P156 H 0



The four digits of Display 3 are shown as follows:

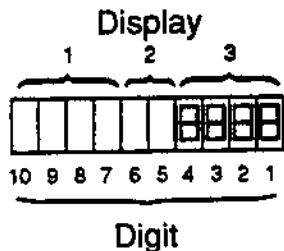

- Digit 1: "0" not activated; key switch closed "1" active
- Digit 2: Bit number of input port(see diagram)
- Digit 3: Port number from which input originated; (see also Table 5 "Port Numbers")
- Digit 4: Not used at present.

Table 5: "Port Numbers"

Port Number	Remarks
0	Input Control Unit
1	Input Control Unit
2	Input Control Unit
3	Input Keypad
4	Input Title Display
5	Input Title Display
6	Input Pick-Up Driver
7	Input Pick-Up Driver Extension
8	Input Reserve Port

P157: Manual control of CD changer via keypad (FB):

In this test program the CD changer is controlled manually via the keypad (Keys 1 to 0). The illustrated functions are executed by pressing the corresponding key depending on whether a CD is in the pick-up or not.

Lift not set down:			Lift is set down or CD is on player:		
1	Lift up	2	Lift up stepwise	3	1.Play CD, afterwards 2x key "1" fastforward
4	Get CD from left	5	Replace CD	6	2.CD in pause
7	Lift down	8	Lift down stepwise	9	1.Play CD, 2.CD in pause
C	Replace CD set lift down	0		H	Replace CD get next one
					7 >FRc afterwards 2x key "1" fastreverse
					8 Play last track
					0 Stop CD replace CD

This test serves also to check the opto couplers in the various end positions. The status of each opto coupler is displayed. If "1" is displayed, then the opto coupler is disrupted. A "0" means the opto coupler is not disrupted. The following table shows the different combinations. The digits 1, 2, 8, 9 and 10 are employed for this purpose.

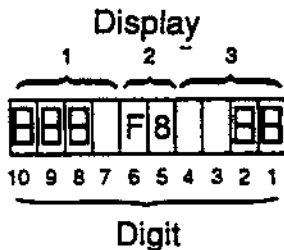

- Digit 1: Counter Wheel (OPSTP)
- Digit 2: Final Position (OPEND)
- Digit 8: Grip right (OPGRR)
- Digit 9: Middle Opto (OPPUM)
- Digit 10: Grip left (OPGRL)

On Display 2 (Digit 5+6) code F8 will be displayed during the test.

Input: P157 H 0



The test is stopped by pressing "C."

13.2 Recording title quantities in title memory

P160: Recording title quantities of all CDs

After calling up this command, the phonograph searches through all CD slots for the number of CDs defined in P042. During the search it reads the number of titles recorded on each CD into the title memory.

This command is used by initial equipping, for example, or if several CDs are exchanged. The number of titles on each CD is registered in the title memory. Simultaneously, the established values are displayed.

Enter: **P 160 H 0**
i.e. result: CD 01 has 24 titles

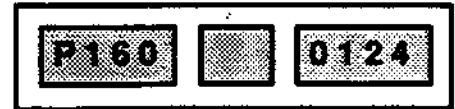

P161: Recording title quantities of one CD

After calling up this command and entering the number of the newly installed CD, its number of titles is registered in the title memory. (nn = 01 to number of P042)

Enter: **P 161 H nn H**
i.e. = CD #67:



P162: Displaying all title memories

After calling up this command and entering the respective code number, the corresponding title data will be displayed.

- 0: Number of titles from CD #01
- 1: Switch to the next CD #
- 2: Return to the previous CD #
- 3: Title number of any CD



With P162,3 the two-digit CD number must be entered and confirmed with "H".

P163: Erasing entry in title memory

If a CD is removed, the corresponding entry in the title memory must be erased and the CD cover removed. The two-digit CD No. must be entered and "H" pressed to confirm.

Enter: **P 163 H nn H**
i.e. remove CD #67



P164: Switching between signal sources

For test purposes different signal input ports for the 3 intended signal sources can be switched individually. This is done with command P164 by entering different code numbers.

- 0: No signal source active, mute (amplifier turned off)
- 1: CD changer is signal source
- 2: A cassette player is signal source.
- 3: A microphone is signal source.

This "manual" switching occurs automatically in normal play according to the signal source that is turned on.

Enter: **P 164 H 2 H**
for cassette player:

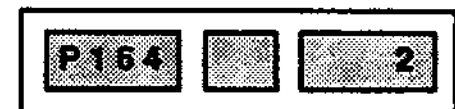

UNIT DESCRIPTION

CONTROL UNIT

FOR NSM-PHONOGRAPGHS

ES V-CD TECHNOLOGY

to
Technical Information, Assy

176 393	THE PERFORMER GRAND II
176 352	THE WIZARD / OLD FASHION WIZARD
176 514	THE PERFORMER CLASSIC
176 610	CD HIDE-AWAY II
176 598	FIREBIRD II

NSM
Aktiengesellschaft
Saarlandstraße 240
6530 Bingen am Rhein

4

Page 401-406 / 421

INDEX

1 FUNCTIONAL DESCRIPTION OF THE CONTROL UNIT ES V

Spare parts list

Schematics CONTROL UNIT CD

1 FUNCTIONAL DESCRIPTION OF THE CONTROL UNIT ES V

The microprocessor (IC 1) on the CONTROL UNIT is the central control chip of the phonograph. It drives, controls and monitors all of the functions of the appliance, e.g. display, keypad, remote control, light organ, coin mechanism, title display, sound and volume and the drive of the CD changer.

The control unit is equipped with a battery buffered RAM (IC 5) including a real time clock. The values of selected titles, credits and actual adjustments of sound and volume are stored in this RAM.

With the service programs several adjustments can be programmed and stored. E.g. general settings, price and monetary settings, free credits, backgroundmusic, autoplay and lock-out titles and so on. The integrated real time clock allows to activate several functions automatically depending on the actual date and time.

Within the RAM of the control unit voluminous statistic counters are stored. They can be evaluated with help of the service programs. They also can be printed out on the DATA PRINT. E.g. popularity of the CDs, top 30 hits, cash box, counters of coin mechanism, selected or played titles, overplays, free credits, background titles, autoplay titles, and so on.

Additional the least 20 error reports are stored in a error stack with date and time of occurrence. This stack can be evaluated and printed out for diagnostics.

Note: The case number of each CD which is placed on the player is stored in the battery buffered RAM. So in case of exchanging either the RAM or the hole CD changer it is to take care that there is no CD on the player. If needed replace the CD with help of the service programs (see chap. 3, "P157").

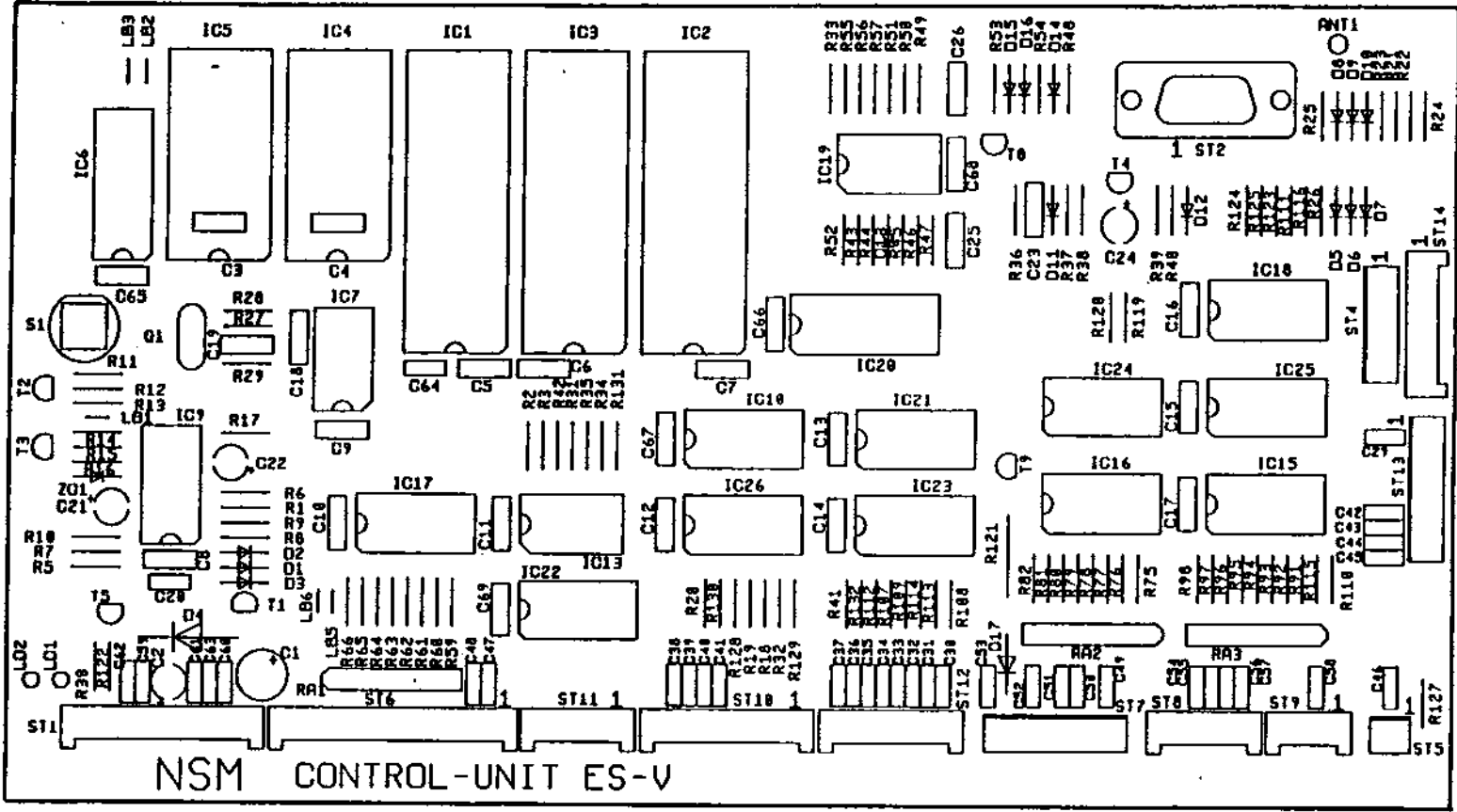

SPARE PARTS LIST

POS.	PART-No.	DESCRIPTION	DATA	QTY
	176 328	<u>CB-CONTROL UNIT ES V, ASSY</u>		1
	173 698	PROFILE, ASSY		1
	171 629	HOLDER		2
ST 9	225 651	PIN PANEL	4 prongs	1
ST 8, 11	225 652	PIN PANEL	6 prongs	2
ST 12	225 653	PIN PANEL	8 prongs	1
ST 10	225 654	PIN PANEL	10 prongs	1
ST 1	225 655	PIN PANEL	12 prongs	1
ST 6	225 656	PIN PANEL	15 prongs	1
ST 5	225 439	PIN PLUG	3 prongs	1
ST 7, 13	225 440	PIN PLUG	10 prongs	2
ST 2	225 828	D-SUB-CONNECTOR	SOCKET 9 prongs	1
Q 1	231 463	OSCILLATOR QUARTZ	3,6864 MHz	1
	222 473	IC-SOCKET	20 prongs	1
IC 6	176 397	IC-PAL, programmed		1
	222 447	IC-SOCKET	28 prongs	2
* IC 4	176 396	IC-MEMORY, programmed	64 K x 8	1
IC 5	231 497	IC-MEMORY	MK 48 T 18 B-20	1
IC 13	221 525	IC-TTL	SN 74 LS 03	1
IC 7	221 652	IC-TTL	SN 74 LS 04	1
IC 8	221 705	IC-TTL	SN 74 LS 74	1
IC 9	221 792	IC-TTL	SN 74 LS 123	1
IC 14	221 852	IC-TTL	SN 74 LS 151	1
IC 20	231 554	IC-TTL	SN 74 HCT 138	1
IC 10	231 518	IC-TTL	SN 74 HCT 4053	1
IC 15-17	221 763	IC-CMOS	HEF 4021 B	3
IC 21, 22	221 541	IC-CMOS	HEF 4049 BC 2	2
IC 23-26	221 810	IC-CMOS	HEF 4050 BP	4
IC 18	221 771	IC-CMOS	HEF 4094	1
IC 19	221 813	IC-LINEAR	LM 339	1
IC 1	231 412	IC-MICROCOMPUTER	R 65 C 02 - P 2	1
IC 2	231 414	IC-MICROCOMPUTER	R 65 C 22 - P 2	1
IC 3	231 462	IC-MICROCOMPUTER	R 65 C 52 - P 3	1
D 1-16	221 114	SI-DIODE	1 N 4148	15
D 17	221 822	SI-DIODE	BA 157	1
D 4	221 539	TRANSZORB-DIODE	TVS 505	1
ZD 1	231 410	ZENER-DIODE	ZPD 6,8	1
LD 1, 2	231 475	LUMINESZENZ-DIODE	LTL-4223-021	2
T 2, 3	221 757	SI-TRANSISTOR	BC 547 B	2
T 9	221 492	SI-TRANSISTOR	BC 517	1
T 1, 4-6	221 459	SI-TRANSISTOR	BC 556 B	4

SPARE PARTS LIST

POS.	PART-No.	DESCRIPTION	DATA		QTY
C 21, 22	220 159	LYTIC	4,7 µF	63 V	2
C 24	220 162	LYTIC	10 µF	63 V	1
C 2	220 160	LYTIC	100 µF	10 V	1
C 1	220 250	LYTIC	100 µF	25 V	1
C 19	220 242	CER.-CAPACITOR	68 pF		1
C 25	220 342	CER.-CAPACITOR	100 pF		1
C 18	220 185	CER.-CAPACITOR	270 pF		1
C 20	220 435	KT-CAPACITOR	4,7 nF		1
C 3-9,					>
11-15, 17,					>
23, 26	220 334	MKT-CAPACITOR	0,1 µF		17
R 38	221 620	RESISTOR	22 Ohm	1/4 W	1
R 20, 25,					>
123-125,					>
132	221 600	RESISTOR	100 Ohm	1/4 W	6
R 122	221 099	RESISTOR	470 Ohm	1/4 W	1
R 30	221 621	RESISTOR	560 Ohm	1/4 W	1
R 11, 54	221 622	RESISTOR	820 Ohm	1/4 W	2
R 9, 12, 13,					>
15, 36, 40	221 029	RESISTOR	1 KOhm	1/4 W	6
R 18, 35	221 031	RESISTOR	2,2 KOhm	1/4 W	2
R 1-3, 16,					>
28, 29	221 033	RESISTOR	3,3 KOhm	1/4 W	6
R 26, 31-					>
34, 41-43,					>
49, 51, 53,					>
119, 127,					>
130, 131	221 034	RESISTOR	4,7 KOhm	1/4 W	14
R 5, 27	221 172	RESISTOR	8,2 KOhm	1/4 W	2
R 8, 10, 14,					>
19, 23, 24,					>
45, 46, 50,					>
52, 107,					>
108-111	221 035	RESISTOR	10 KOhm	1/4 W	15
R 7, 21, 22,					>
39, 55, 56,					>
67-74, 83-					>
90, 99-106,					>
112-116,					>
120, 128,					>
129	221 604	RESISTOR	22 KOhm	1/4 W	38
R 6	221 601	RESISTOR	27 KOhm	1/4 W	1
R 47, 48,					>
57, 59-66,					>
75-82, 91-					>
98	221 038	RESISTOR	47 KOhm	1/4 W	27
R 17, 37,					>
44	221 048	RESISTOR	100 KOhm	1/4 W	3
R 121	221 273	RESISTOR	10 Ohm	1/2 W	1

Address ~~PA~~
9-25
26-33 Data

PA 40
Hi +5V

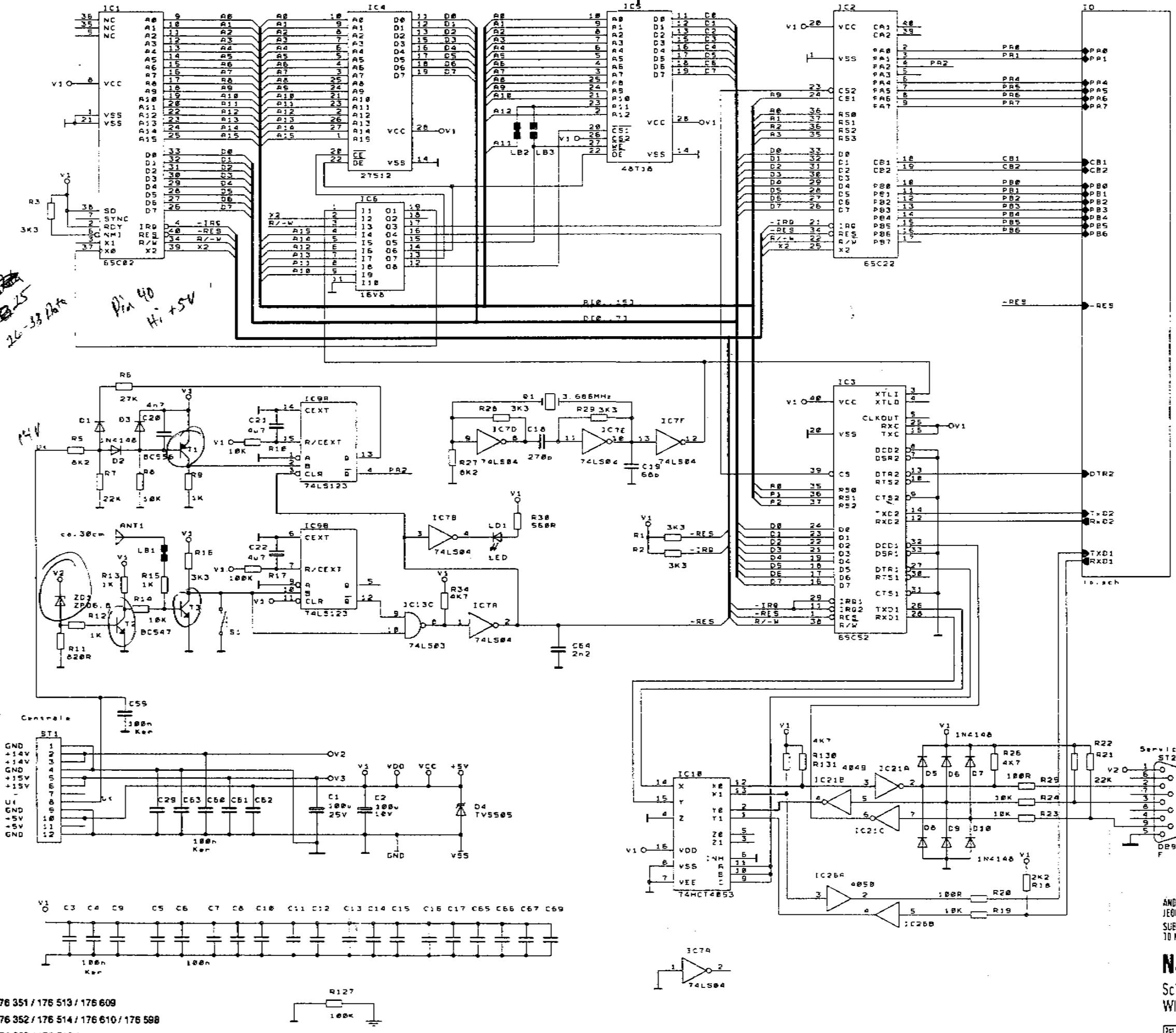

ÄNDERUNGEN IM SINNE DES TECHN. FORTSCHRITTES VORBEHALTEN,
JEDOCH KEINE NACHRÜSTPFLICHT!
SUBJECT TO TECHNICAL MODIFICATION WITHOUT OBLIGATION
TO MODIFY EQUIPMENT ALREADY DELIVERED!

NSM MUSIKAUTOMATEN PHONOGRAPHS ES V-CD TECHNOLOGY
Schaltbild WIRING DIAGRAM CONTROLLER

29.06.92 Breuer

176 392 / 176 351 / 176 513 / 176 609
176 393 / 176 352 / 176 514 / 176 610 / 176 598
176 394 / 176 353 / 176 515 /
07/92

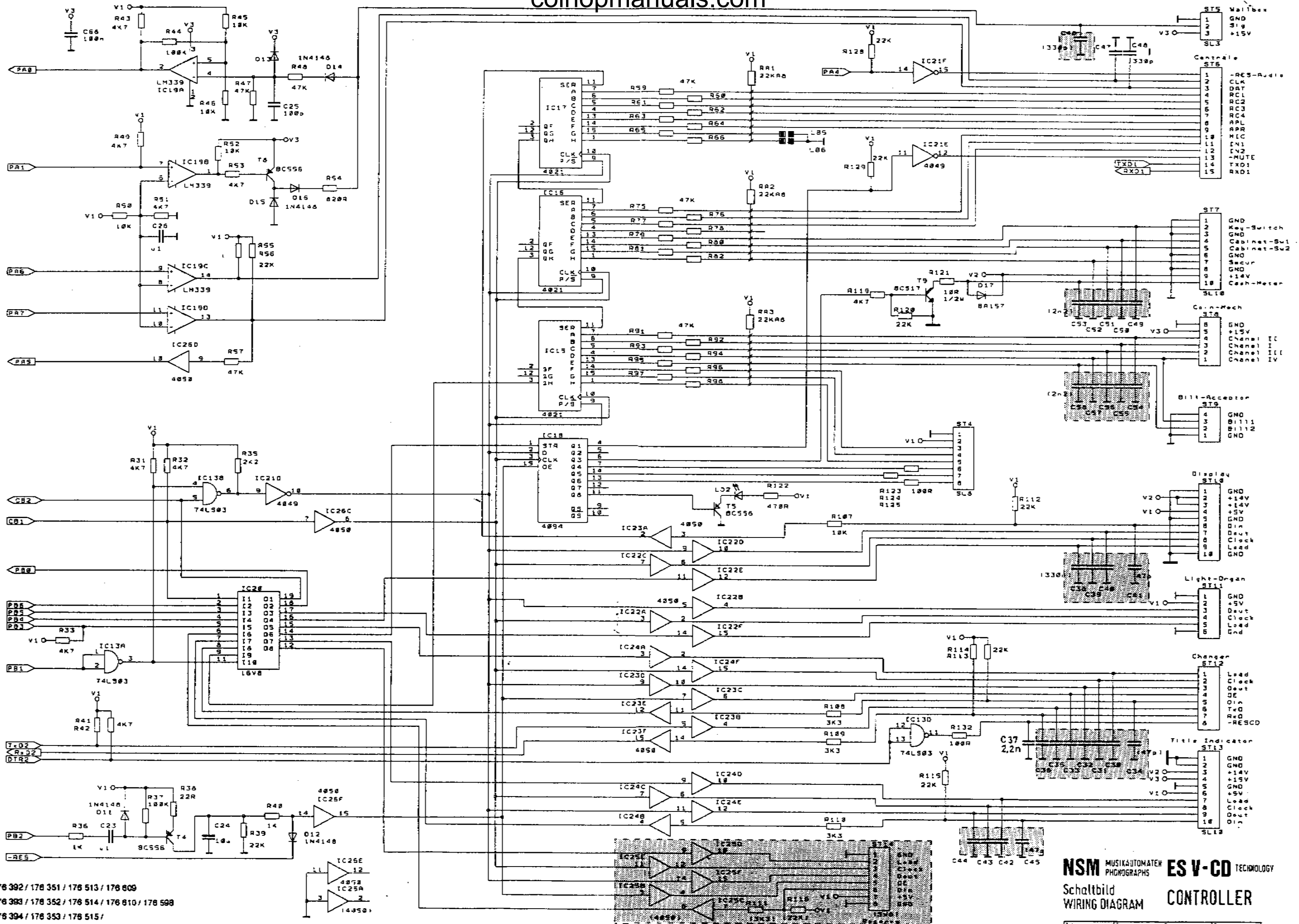

176 392 / 176 351 / 176 513 / 176 809
 176 393 / 176 352 / 176 514 / 176 810 / 176 598
 176 394 / 176 353 / 176 515 /
 07/92

ÄNDERUNGEN IM SINNE DES TECH. FORTSCHRITTES VORBEHALTEN,
 JEDOCH KEINE NACHRÜSTPFLICHT!

SUBJECT TO TECHNICAL MODIFICATION WITHOUT OBLIGATION
 TO MODIFY COMPONENTS IN CASE OF NEW

gerasterte Bauteile sind nicht eingebaut!
 GOTTED COMPONENTS ARE NOT INSTALLED!

NSM MUSIKAUTOMATEN PHONOGRAPHS **ES V-CD** TECHNOLOGY
 Schaltbild WIRING DIAGRAM **CONTROLLER**

29.06.92 Braun

421/2

UNIT DESCRIPTION

DISPLAY / KEYBOARD

FOR NSM-PHONOGRAPHS

ES V-CD TECHNOLOGY

to
Technical Information, Assy

176 393	THE PERFORMER GRAND II
176 352	THE WIZARD / OLD FASHION WIZARD
176 514	THE PERFORMER CLASSIC
176 610	CD HIDE-AWAY II
176 598	FIREBIRD II

NSM
Aktiengesellschaft
Saarlandstraße 240
6530 Bingen am Rhein

5

Page 501-505 / 511

INDEX

- 1** **FUNCTION**
- 1.1** **Display**
- 1.2** **Keyboard**

Spare parts list

1 FUNCTION

1.1 Display

The shift registers IC 301 through IC 303 are the output ports for the display control.

The display is operated in the multiplex mode.

The segment information is prepared for one digit with IC 302 and IC 303 via drivers IC 308 and IC 309.

The transistors T 303 through T 305 are controlled by IC 307 via IC 301 and switch on the appropriate multiplex level for 4 milliseconds.

Resistors R 332 to R 345 determine the segment current.

Lamps L 1 to L 5 are controlled statically via IC 307, Pin 12 and 14 and IC 306, Pin 19, 11, 12.

Resistors R 325 to R 329 limit the transient current.

The load signal for the output shift registers is monitored by circuit IC 306, Pin 4 and 13; R 306; C 303; D 301.

During the duration of the load signal the display is dark.

C 303 is discharged via D 301 and IC 306, Pin 13.

OE of IC 301 to IC 303 becomes LOW and thereby inactive.

If no load signal occurs, OE becomes inactive via R 305.

Capacitor C 302 avoids lighting up of the digits after switching on.

1.2 Keyboard

IC 301 is an input port for the keyboard which is connected to plug ST 302.

The circuit with diodes D 302 - D 307 and transistors T 306, T 307 codes the keyboard matrix to a 4-bit signal combination.

SPARE PARTS LIST

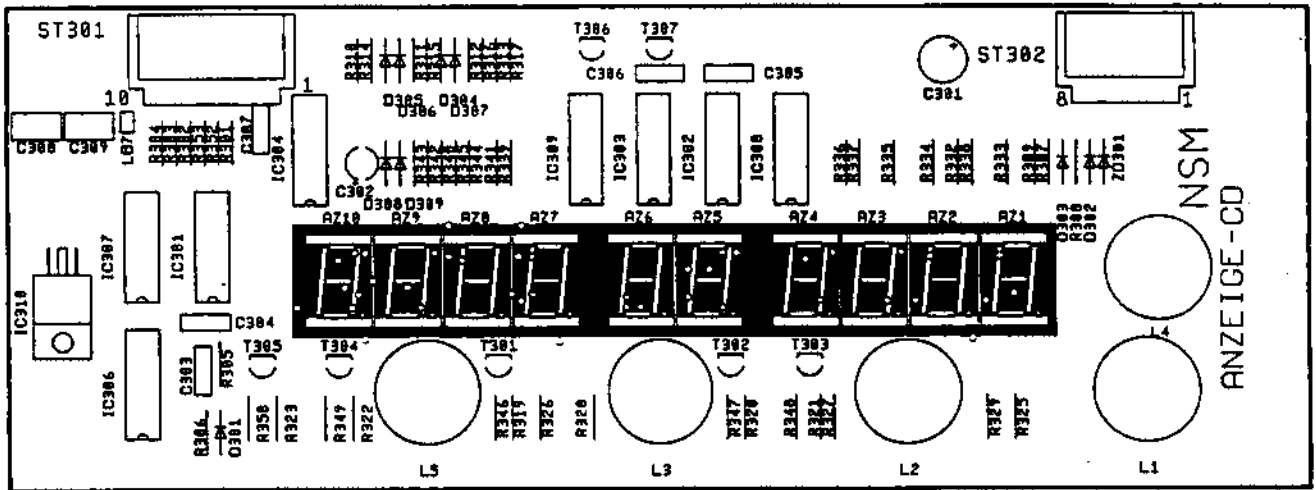

SPARE PARTS LIST

POS.	PART-No.	DESCRIPTION	DATA		QTY
	173 664	<u>CB-DISPLAY CD. ASSY</u>			1
ST 302	225 663	PIN PANEL	8 prongs	90°	1
ST 301	225 664	PIN PANEL	10 prongs	90°	1
AZ 1-10	231 416	DISPLAY	TD SL 5150		10
	176 413	TUBUS			1
	171 629	HOLDER			4
IC 310	221 573	IC-VOLTAGE	12 V 1 A		1
IC 301-303	221 771	IC-CMOS	HEF 4094 B		3
IC 304	221 763	IC-CMOS	HEF 4021 B		1
IC 306-309	221 497	IC-LINEAR	ULN 2003 A		4
D 301-309	221 114	SI-DIODE	1 N 4148		9
T 301-305	231 240	SI-TRANSISTOR	BC 636 F		5
T 306, 307	221 283	SI-TRANSISTOR	BC 212 B		2
C 303-307	220 334	MKT-CAPACITOR	0,1 µF	63 V	5
C 308, 309	220 332	MKT-CAPACITOR	0,33 µF	63 V	2
C 302	220 249	LYTIC	1 µF	63 V	1
C 301	220 162	LYTIC	10 µF	63 V	1
R 301	221 611	RESISTOR	10 Ohm	1/4 W	1
R 306, 332-350	221 627	RESISTOR	1,2 KOhm	1/4 W	20
R 302-304, 307-309, 314-317, 319-323, 354	221 033	RESISTOR	3,3 KOhm	1/4 W	16
R 310-313	221 038	RESISTOR	47 KOhm	1/4 W	4
R 305	221 009	RESISTOR	1 MOhm	1/4 W	1
R 325-329	231 366	MET.-RESISTOR	10 Ohm	1/4 W	5
L 1-5	225 533	LAMP SOCKET			5
	226 056	LAMPS	12 V 2 W		5
	173 900	DISPLAY, ASSY	12-fach		1

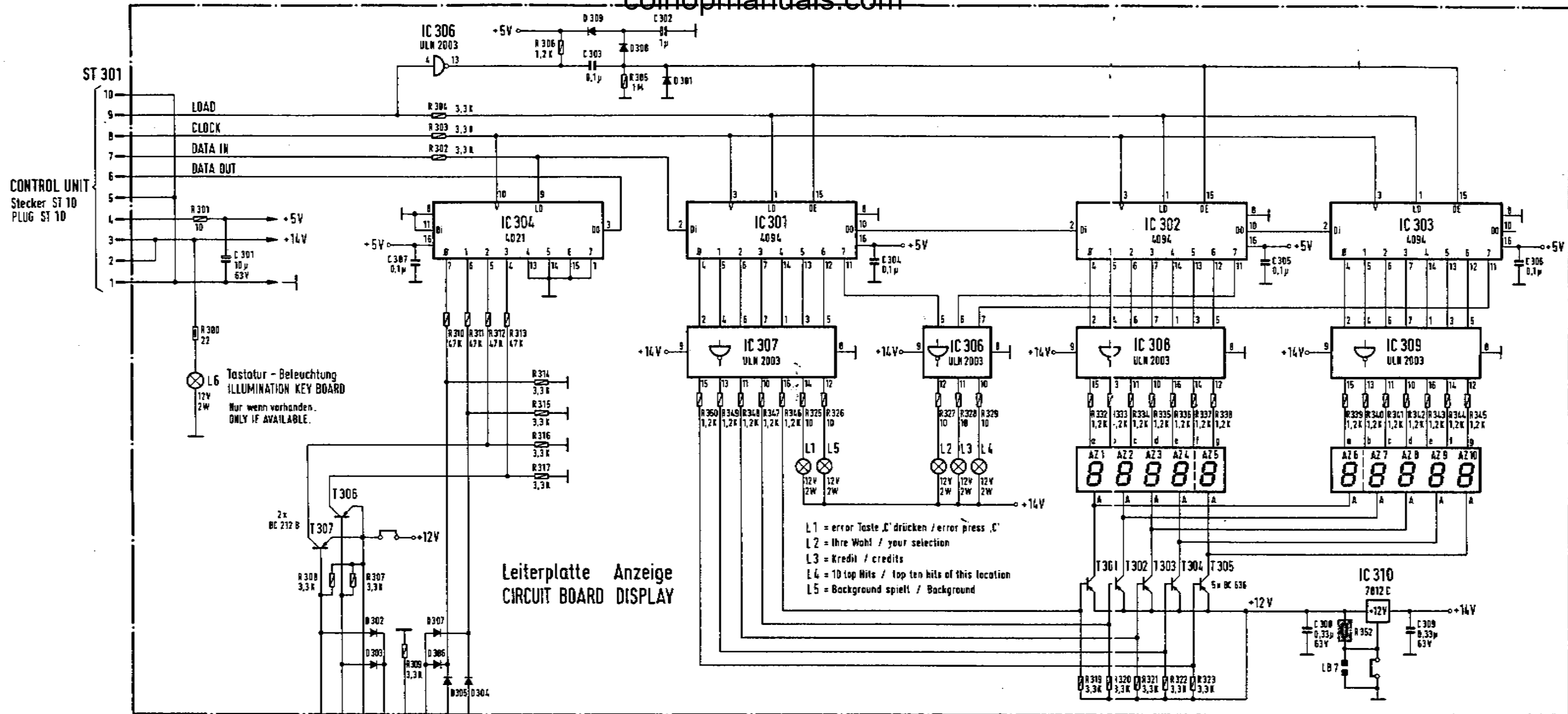

Tastatur - Beleuchtung
ILLUMINATION KEY BOARD
Nur wenn vorhanden.
ONLY IF AVAILABLE.

Leiterplatte Anzeige
CIRCUIT BOARD DISPLAY

- L1 = error Taste „C“ drücken / error press „C“
- L2 = Ihre Wahl / your selection
- L3 = Kredit / credits
- L4 = 10 top Hits / top ten hits of this location
- L5 = Background spielt / Background

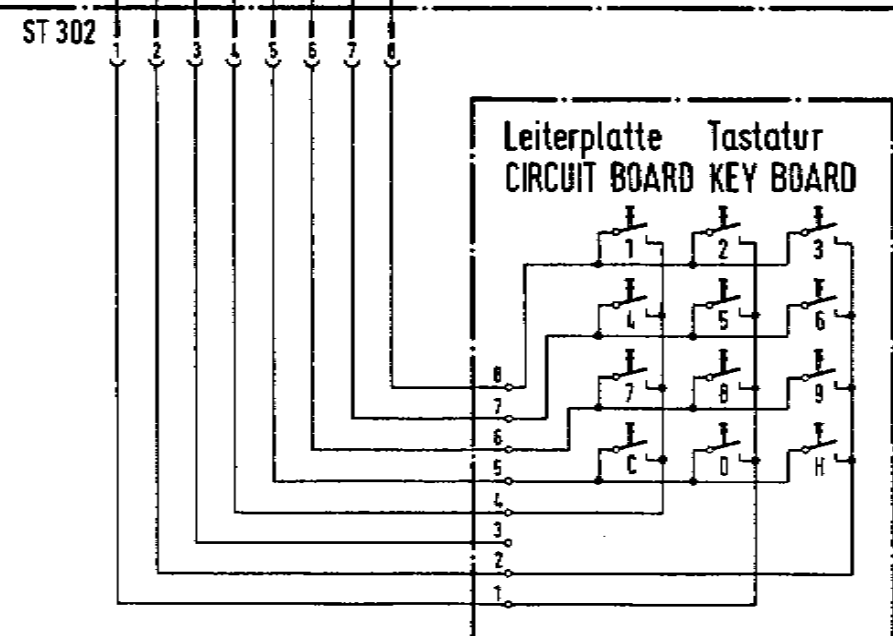

Draufsicht: Display
TOP VIEW: DISPLAY

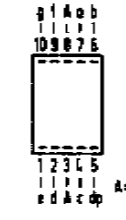

Draufsicht: Spannungsregler IC 310
TOP VIEW: VOLTAGE REGULATOR IC 310



von unten gesehen
BOTTOM VIEW

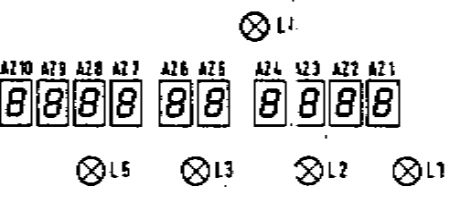
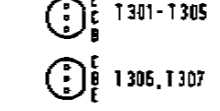

gerasterte Bauteile sind nicht eingebaut!
DOTTED COMPONENTS ARE NOT INSTALLED!

ÄNDERUNGEN IM SINNE DES TECHN. FORTSCHRITTES VORBEHALTEN,
JEDOCH KEINE NACHRÜSTPFLICHT!
SUBJECT TO TECHNICAL MODIFICATION WITHOUT OBLIGATION
TO MODIFY EQUIPMENT ALREADY DELIVERED!

NSM MUSIKAUTOMATEN PHONOGRAPHS **ESV-CD** TECHNOLOGY

Schaltbild Anzeige / Tastatur
WIRING DIAGRAM DISPLAY / KEY BOARD

Dat.	10.04.92	Ver.	Braun	Zeich.	Wagner	Gepr.	Stamm
------	----------	------	-------	--------	--------	-------	-------

UNIT DESCRIPTION

CENTRAL UNIT

FOR NSM-PHONOGRAPHS

ES V-CD TECHNOLOGY

to
Technical Information, Assy

176 393	THE PERFORMER GRAND II
176 352	THE WIZARD / OLD FASHION WIZARD
176 514	THE PERFORMER CLASSIC
176 610	CD HIDE-AWAY II
176 598	FIREBIRD II

NSM
Aktiengesellschaft
Saarlandstraße 240
6530 Bingen am Rhein

6

Page 601-612 / 621

INDEX

- 1 **FUNCTION**
- 1.1 **Power Supply**
- 1.2 **Amplifier**
- 1.3 **Signal path**
- 1.4 **Adjustment of volume and sound characteristics**
- 1.5 **MIC socket, microphone connection**
- 1.6 **Tape recorder connection**
- 1.7 **Connection of auxiliary amplifier**

- 2 **Adjustment instructions for trimmer of central unit and output stage**

- 3 **Repair aid**
- 3.1 **Output stage**
- 3.2 **Tracing sound signal**

1 FUNCTION

The power supply, fan controls, stereo amplifier with inputs for microphone, CD and tape are all integrated on one circuit board "CENTRAL UNIT".

The output stages and the fan are connected to the central unit via ST 4, ST 8, ST 9. The music power per channel is 200 watts when matched to a loudspeaker impedance of 2 ohms.

1.1 Power Supply

The power transformer supplies 22 V, 2 x 11,5 V and 2 x 43 V from three separate secondary coils. The supply voltage for the output stages is supplied with 2 x 43 V by a two-way rectifier (D 1) and the center tap of the transformer.

The supply voltage for the voltage regulators VR1 (V3 = +15 V) and VR2 (+VA = +15 V) is supplied with 22 V by a bridge rectifier (D2-D5) from the transformer.

The supply voltage for the voltage regulators VR 3 (V1 = +5 V), VR 4 (+VM = + 10 V) are supplied with 2 x 11,5 V by a two-way rectifier (D6 / D8) and the center tap of the transformer.

Appropriate the supply voltage for VR 5 (-VM = -10 V) is supplied by D7 / D9 and the supply voltage for VR 6 (-VA = -15 V) is supplied by a voltage doubler D13, D14, D15 and C20 from the same coils of the transformer.

Fusing is accomplished with

Si 1, Si 2 = 6,3 A for the voltage V Amp.

Si 3, Si 4 = 3,15 A for voltages V1, V2, +VM, -VM, -VA

Si 5 = 2,5 A for voltages V3, V4, +VA

The LED's indicate at the same intensity the following supply voltages:

LED 1 = +28 V (V4)

LED 2 = +14 V (V2)

LED 3 = -14 V

LED 4 = -22 V

LED 5 = +60 V (V Amp.).

The TRIAC TC 1 controls the output stage fan depending upon the operational state of the amplifier (REJECT); i.e. the fan only runs when the amplifier is not muted.

1.2 Amplifier

The stereo amplifier is build up with a siemens audio processor with 3 quadruple OpAmps 54 diodes, 23 transistors and 6 voltage regulators.

The output stage is designed without induction coils or transformers and is therefore ironless.

At full volume level the music power is 200 watts per channel.

1.3 Signal path

The input signals

- MIC is connected via the microphon amplifier IC 4 B and the background mixer IC 4 A to Pin 3 (right channel) and Pin 26 (left channel)
 - TB is connected via the pre-amplifiers IC 3 C respectively IC 3 D to Pin 2 (right channel) and Pin 27 (left channel)
 - CD (symmetrical inputs) is connected via the pre-amplifiers IC 3 A respectively IC 3 B to Pin 1 (right channel) and Pin 28 (left channel)
- of the input selection circuit of the audio processor.

When the microphone switch is actuated (Pin 5 of socket MIC to GND) the MIC is switched precedencely. That means TB or CD are interrupted.

Beginning at a level higher then 3 mV of the signal, the TB input is automatically active, if there is no CD played or no microphone switched 1 on. The control circuit is build with IC 4 C and IC 4 D.

On output BU 4 / BU 5 (Out R / Out L) a signal is served to steer towards an additional amplifier.

Via an AVC-stage (automatic volume control), the switch for MONO, STEREO and S-STEREO the audio signal reaches the sound control network and the volume stage of the I² C-bus controlled audio processor.

The output signals of this processor (Pin 13 / Pin 16) are connected to the inputs of the driver stage T 4 and T 6.

The parallel complementary power Darlington transistors T 151 through T 154 in the output stage allow a minimum loudspeaker impedance of 2 ohms.

Quiescent current compensation and thermic stabilization is accomplished with T 150, the quiescent current setting with TR 250. The amplifier is equipped with two protective circuits against overload mismatching and thermic overload.

T 155 acts as a threshold switch for the electronic fuse. When the emitter current of the output transistors exceeds a certain value, T 8 or T 9 is switched through by T 155 and reduces the volume via the control unit.

The actuation of the electronic fuse is controlled by the control unit.

When its fuse is tripped a number of times within a certain period, the volume is reduced automatically by one step each time until the electronic fuse is no longer activated.

The terminating impedance at the loudspeaker output should not be less than 2 ohms. In the case of mismatching (less than 2 ohms), or short-circuit in the loudspeaker cable, the limiting circuit is actuated.

The result is distorted sound reproduction or reduction of the volume. After elimination of the mismatch the amplifier is ready for operation and the volume can be readjusted.

The thermal switch on the heat sink switches off the power supply to the output stage when the heat sink temperature reaches approx. 90° C (cooling malfunctioning). LED 150 is dark. The switch-on point (following cooling down) is approx. 60° C (switch-on hysteresis).

1.4 Adjustment of volume and sound characteristics

Volume adjustment for normal play mode is done by use of the command P053 of the service programm. It is done separately for the right and the left channel:

keys "1" / "3" give more volume (left/right)
keys "7" / "9" give less volume (left/right)
keys "4" / "6" give a medium value (left/right) of the volume
keys "2" / "8" are controlling both channels (more/less).

Treble and Bass are controlled with P054 for both channels:

keys "1" / "7" more/less of bass key "4" medium value of bass
keys "3" / "9" more/less of treble key "6" medium value of treble.

The necessary adjustment depend on the given environmental conditions.

With the potentiometer POT 2 the volume of microphone signal is controlled and with potentiometer POT 1 the volume of sound while the microphone is active.

The adjustment of POT 2 depends on the distance between the phonograph and the microphone (feedback!)

The switch S1 is for selecting:

MONO: e.g. for separated music in different rooms.
STEREO: normal position
S-STEREO: base wide function

1.5 MIC socket, Microphone Connection

A dynamic microphone with an impedance of 200 ohms - 600 ohms with switch for relay control can be used.

NSM option accessories:

Microphone Order No. 224 223
Connection cable Order No. 171 880 (length: 10 m)

1.6 Tape Recorder Connection

The TB socket (cinch) allows to record the music from the phonograph on a tape recorder as well as to play music from a tape recorder by the phonograph.

The AF signal (analog signal) for recording on a tape recorder is on BU 4 and BU 5 and can be connected directly with a stereo cable.

For playback of a tape via the phonograph BU 2 and BU 3 are used.

1.7 Connection of an additional Amplifier

An additional amplifier can be connected to BU 4 and BU 5.

The input sensitivity of the external amplifier should be 1 V at a minimum input impedance of 10 KOhms.

2 Adjustment Instructions for Trimmer of Central Unit and Output Stage

TR 150 for quiescent current adjustment of the output stage: The quiescent current must be set to 40 mA +5 mA when volume level is 0.

After replacement of the output transistor T 151 through T 154 a correction may be required. Therefore the fuse Si 150 or the thermal switch is to be replaced by an ampere-meter.

3 Repair Aid

Amplifier integrated in central unit ES V

Malfunction: No sound, no output power:

It is assumed that LED 1 to LED 5 light with the same intensity and that the power supply is therefore O.K., the CD is on the CD player being played, and normal volume was set in program step P053 to "31".

3.1 Output Stage

LED 150 on the output stage circuit board is dark. Malfunction probably located in the output stage; check Si 150 and replace if required. If the fuse blows again, the output transistors are defective.

Remove output stage unit, pull out cover plates on the bottom. Check for short-circuit on transistors T 151/T 152 T 153/T 154 with ohmmeter. Since the transistors are connected in parallel, it is only possible to test them in pairs.

For individual testing one transistor must be unsoldered from the defective pair. After replacement of the defective transistors the quiescent current must be readjusted with TR 150 according to the adjustment instructions.

3.2 Tracing Sound Signal

Trace the sound signal arriving at CD plug according to the table below.
The point where the signal is missing is probably the cause of the malfunction.

AF Signal Point	Cause of Malfunction When Signal Missing
IC 1, Pin 1 or Pin 28	IC 3
IC 1, Pin 5 or Pin 24	IC 1
IC 1, Pin 6 or Pin 23	IC 2 (AVC)
IC 1, Pin 13 or Pin 16	IC 1
T 5 / T 7 (collector)	T 4, T 6, T 5, T 7

If the signal is there up to T 5, T 7, but no output signal arrives at the output stage, plug connectors ST 8 / ST 9 as well as the output stage have to be checked.

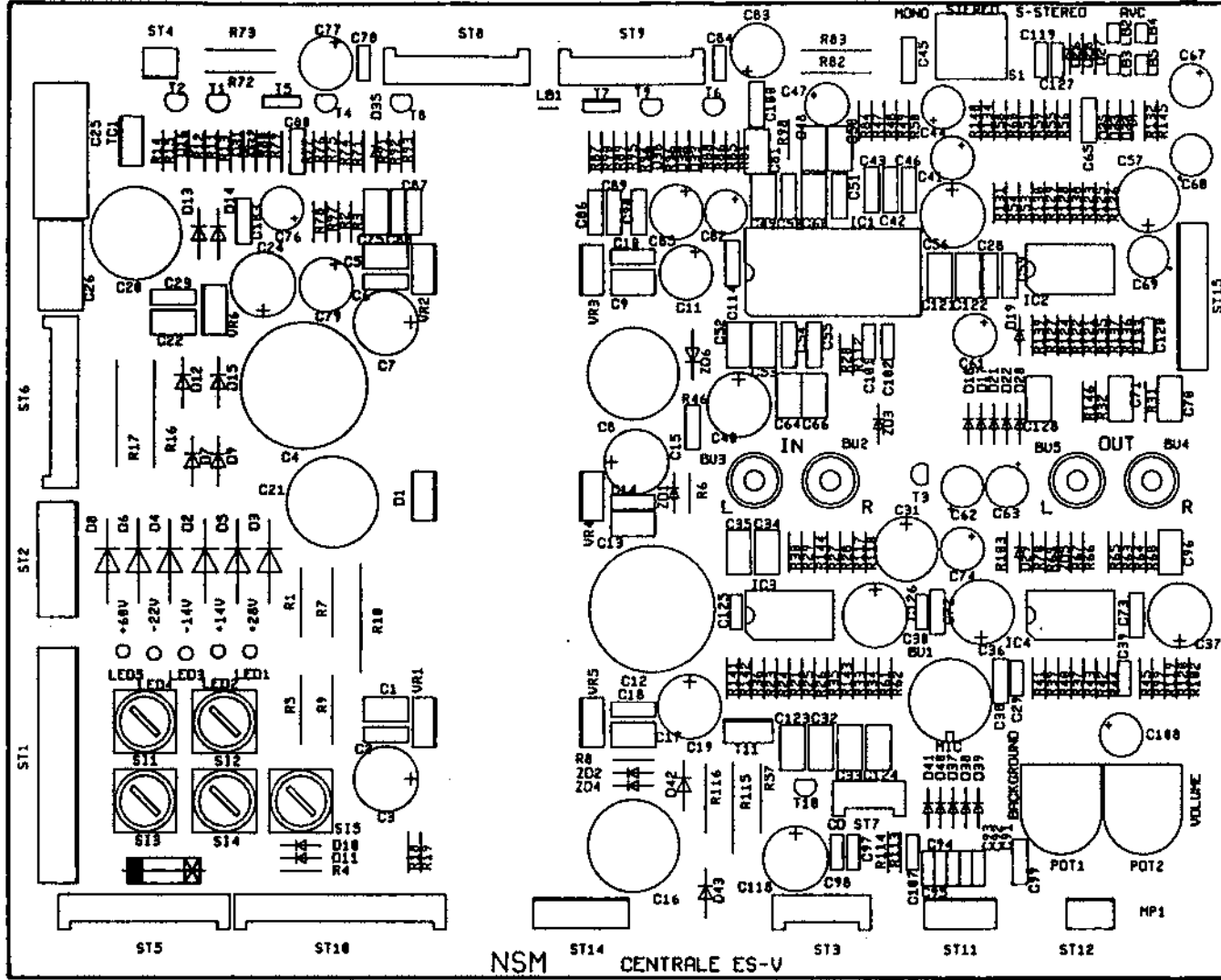

SPARE PARTS LIST

POS.	PART-No.	DESCRIPTION	DATA	QTY	
	176 326	<u>CENTRALE ES V, ASSY</u>	<u>50 Hz</u>	1	
SI 5	225 538	FUSE	T 2,5 A	1	
SI 3,4	225 029	FUSE	T 3,15 A	2	
SI 1,2	225 374	FUSE	T 6,3 A	2	
	225 747	CAP		5	
	176 327	<u>CENTRALE ES V, ASSY</u>	<u>60 Hz</u>	1	
SI 5	225 222	FUSE	2,5 A	1	
SI 3,4	225 225	FUSE	3,2 A	2	
SI 1,2	225 218	FUSE	6,25 A	2	
	225 748	CAP		5	
	150 687	COOLING PLATE		2	
	225 746	FUSE HOLDER		5	
	173 698	PROFILE, ASSY		1	
	171 629	HOLDER		2	
BU 1	225 244	SOCKET	S 5 prongs	1	
BU 2-5	225 986	RCA-SOCKET	BTOR 1 L	4	
S 1	222 550	SLIDE SWITCH	25149 NLDH 6	1	
ST 2	225 804	PIN PLUG	RM 3,96	6 prongs	1
ST 1	225 807	PIN PLUG	RM 3,96	12 prongs	1
ST 4	225 439	PIN PLUG	RM 2,5	3 prongs	1
ST 12	225 418	PIN PLUG	RM 2,5	4 prongs	1
ST 11	225 443	PIN PLUG	RM 2,5	6 prongs	1
ST 14	225 444	PIN PLUG	RM 2,5	8 prongs	1
ST 7	225 651	PIN PANEL	RM 2,5	4 prongs	1
ST 3	225 711	PIN PANEL	RM 2,5	6 prongs	1
ST 8,9	225 654	PIN PANEL	RM 2,5	10 prongs	2
ST 15	225 655	PIN PANEL	RM 2,5	12 prongs	1
ST 5,6	225 714	PIN PANEL	RM 2,5	12 prongs	2
ST 10	225 656	PIN PANEL	RM 2,5	15 prongs	1
VR 3,4	221 572	IC-VOLTAGE	+ 5 V	1 A	2
VR 5	221 537	IC-VOLTAGE	- 5 V	1 A	1
VR 1,2	221 476	IC-VOLTAGE	+15 V	1,5 A	2
VR 6	231 498	IC-VOLTAGE	-15 V	1,5 A	1
	222 447	IC-SOCKET	28 prongs		1
IC 1	231 540	IC-LINEAR	TDA 4390		1
IC 2-4	231 355	IC-LINEAR	TL 074		3
TC 1	231 028	TRIAC	TIC 206 D		1

SPARE PARTS LIST

POS.	PART-No.	DESCRIPTION	DATA	QTY
D 10, 11,				>
16-20,				>
31-41	221 114	SI-DIODE	1 N 4148	27
D 7, 9, 13,				>
14, 15, 42,				>
43	221 115	SI-DIODE	1 N 4004	8
D 2-6, 8	221 463	SI-DIODE	BY 251	6
D 1	231 202	SI-DUO-DIODE	BYV 32/100	1
ZD 1-3, 5	231 079	ZENER-DIODE	ZPD 4,7	4
ZD 4	231 509	ZENER-DIODE	ZPD 10	1
ZD 6	221 406	ZENER-DIODE	ZY 12	1
LED 1-5	231 475	LUMINESZENZ-DIODE	LTL-4223-021	5
T 11	231 150	SI-TRANSISTOR	TIP 130	1
T 5, 7	221 488	SI-TRANSISTOR	BD 139-10	2
T 1, 3,				>
8-10	221 757	SI-TRANSISTOR	BC 547 B	5
T 2, 4, 6	221 459	SI-TRANSISTOR	BC 556 B	3
C 29, 39,				>
125, 126	220 266	CER.-CAPACITOR	27 pF	4
C 73	220 181	CER.-CAPACITOR	47 pF	1
C 80, 86	220 185	CER.-CAPACITOR	270 pF	2
C 2, 6, 10,				>
14, 18, 23,				>
38, 41, 42,				>
44, 45, 50,				>
51, 54, 55,				>
59, 65, 87				>
-90, 99,				>
114	220 481	CER.-CAPACITOR	0,1 µF	23
C 1, 5, 9,				>
13, 17, 22,				>
28, 32-35,				>
48, 49, 52,				>
53, 58, 60,				>
64, 66, 70,				>
71, 75, 81,				>
98, 121-				>
124	220 332	MKT-CAPACITOR	0,33 µF	28
C 107	220 335	MKT-CAPACITOR	22 nF	1
C 120	220 426	MKT-CAPACITOR	47 nF	1
C 28	220 336	MKT-CAPACITOR	2,2 µF	1
C 25	220 460	MKT-CAPACITOR	3,3 µF	1
C 101, 102	220 400	KT-CAPACITOR	1500 pF	2
C 72, 78,				>
84, 91-95,				>
119	220 435	KT-CAPACITOR	4700 pF	9

SPARE PARTS LIST

POS.	PART-No.	DESCRIPTION	DATA		QTY
C 61, 67	220 249	LYTIC	1 µF	63 V	2
C 47, 76,					>
82	220 162	LYTIC	10 µF	63 V	3
C 74, 77,					>
83	220 158	LYTIC	47 µF	40 V	3
C 118	220 247	LYTIC	47 µF	63 V	1
C 11	220 160	LYTIC	100 µF	10 V	1
C 3, 7, 15,					>
19, 24, 30,					>
31, 36, 37,					>
40, 56, 57	220 250	LYTIC	100 µF	25 V	12
C 79, 85	220 390	LYTIC	100 µF	40 V	2
R 80, 90	221 095	RESISTOR	6,8 Ohm	1/4 W	2
R 2, 21, 37,					>
51, 71, 81	221 611	RESISTOR	10 Ohm	1/4 W	6
R 87, 88	221 096	RESISTOR	56 Ohm	1/4 W	2
R 64, 93,					>
96	221 600	RESISTOR	100 Ohm	1/4 W	3
R 44	221 099	RESISTOR	470 Ohm	1/4 W	1
R 112	221 100	RESISTOR	680 Ohm	1/4 W	1
R 3, 4, 6,					>
8, 43, 65,					>
91, 94	221 029	RESISTOR	1 KOhm	1/4 W	8
R 15, 79,					>
89	221 030	RESISTOR	1,5 KOhm	1/4 W	3
R 31, 32	221 031	RESISTOR	2,2 KOhm	1/4 W	2
R 77, 78	221 033	RESISTOR	3,3 KOhm	1/4 W	2
R 27, 29,					>
54, 56,					>
117-122	221 034	RESISTOR	4,7 KOhm	1/4 W	10
R 134, 140	221 607	RESISTOR	6,8 KOhm	1/4 W	2
R 48, 50	221 172	RESISTOR	8,2 KOhm	1/4 W	2
R 11, 13, 14,					>
18-20, 67,					>
114, 125,					>
127	221 035	RESISTOR	10 KOhm	1/4 W	10
R 133, 139	221 603	RESISTOR	12 KOhm	1/4 W	2
R 131, 137	221 036	RESISTOR	15 KOhm	1/4 W	2
R 132, 138	221 501	RESISTOR	18 KOhm	1/4 W	2
R 12, 39,					>
70, 113	221 604	RESISTOR	22 KOhm	1/4 W	4
R 68	221 037	RESISTOR	33 KOhm	1/4 W	1
R 145, 146	221 623	RESISTOR	39 KOhm	1/4 W	2
R 23-26, 28,					>
30, 41, 42,					>
45, 58, 69,					>
92, 95, 99,					>
120, 130,					>
135, 136,					>
141-144	221 038	RESISTOR	47 KOhm	1/4 W	22

SPARE PARTS LIST

POS.	PART-No.	DESCRIPTION	DATA	QTY
R 74, 84, 97, 98	221 039	RESISTOR	56 KOhm 1/4 W	> 4
R 47, 49, 53, 55	221 629	RESISTOR	68 KOhm 1/4 W	> 4
R 123, 124	221 044	RESISTOR	82 KOhm 1/4 W	2
R 40, 66, 75, 85, 126, 128	221 048	RESISTOR	100 KOhm 1/4 W	> 6
R 86, 76	221 045	RESISTOR	150 KOhm 1/4 W	2
R 103	221 047	RESISTOR	330 KOhm 1/4 W	1
R 33-36, 59-63	221 049	RESISTOR	470 KOhm 1/4 W	> 9
R 102	221 982	RESISTOR	3,3 MOhm 1/4 W	1
R 57	221 161	RESISTOR	47 Ohm 1/2 W	1
R 72, 82	221 230	RESISTOR	470 Ohm 1/2 W	2
R 5, 7	221 183	RESISTOR	1 KOhm 1/2 W	2
R 73, 83	221 210	RESISTOR	1,5 KOhm 1/2 W	2
R 1, 9	221 184	RESISTOR	2,2 KOhm 1/2 W	2
R 118	221 397	RESISTOR	4,7 KOhm 1/2 W	1
R 115	221 276	WIRE WOUND RESISTOR	470 Ohm 1 W	1
R 10	231 232	WIRE WOUND RESISTOR	6,8 KOhm 1 W	1
R 16, 17	231 176	WIRE WOUND RESISTOR	0,22 Ohm 4 W	2
Pot 1, 2	231 553	TRIMMER RESISTOR	500 KOhm 0,15 W	2
	231 235	SHAFT	red	2

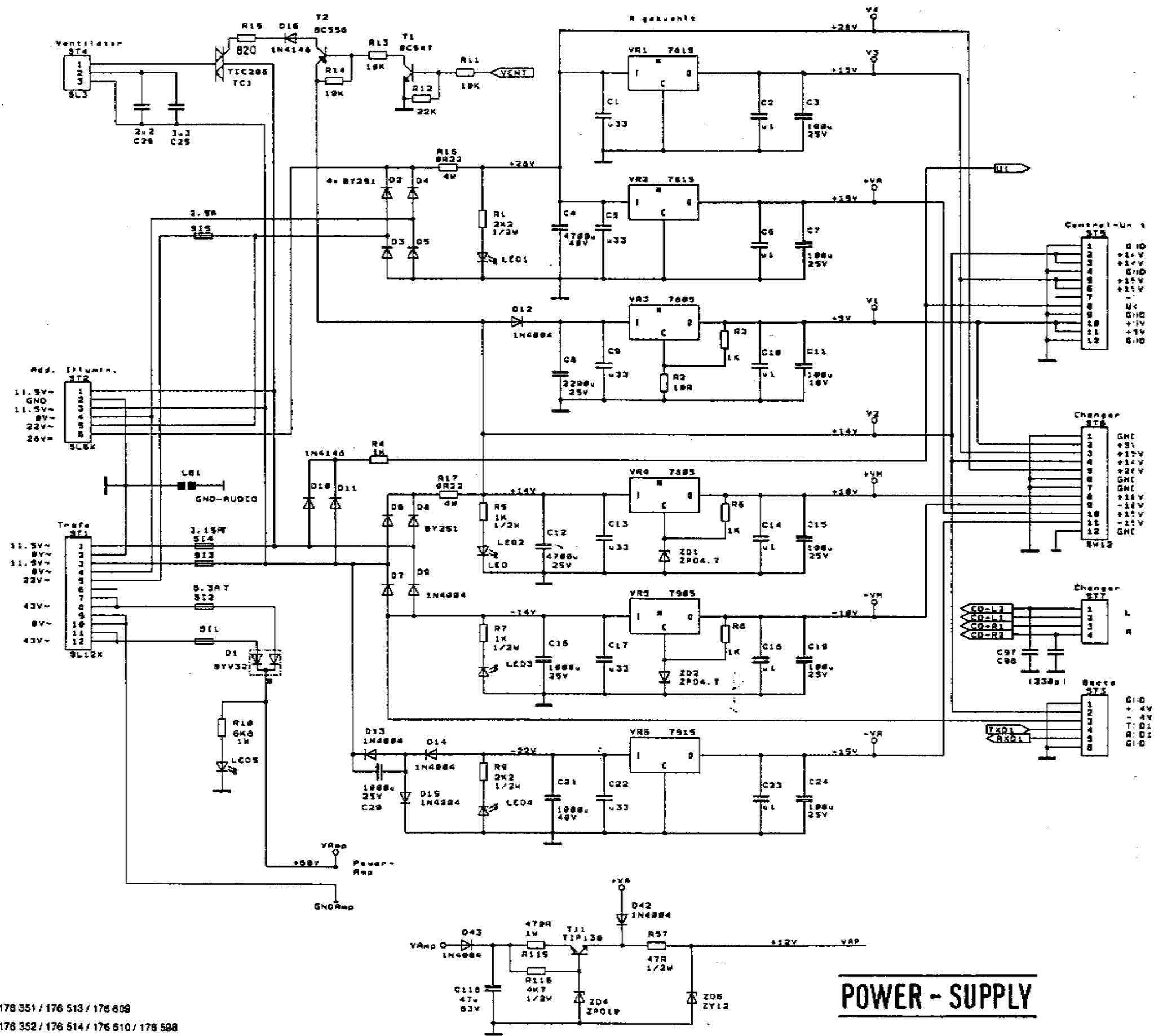

POWER - SUPPLY

176 392 / 176 351 / 176 513 / 176 608
 176 393 / 176 352 / 176 514 / 176 610 / 176 598
 176 394 / 176 353 / 176 515 /
 07/92

ÄNDERUNGEN IM SINNE DES TECHN. FORTSCHRITTES VORBEHALTEN,
 JEDOCH KEINE NACHRÜSTPFLICHT!
 SUBJECT TO TECHNICAL MODIFICATION WITHOUT OBLIGATION
 TO MODIFY EQUIPMENT ALREADY DELIVERED!

NSM MUSIKAUTOMATEN **ES V-CD** TECHNOLOGY
 PHONOGRAPHS
 Schaltbild WIRING DIAGRAM **CENTRALE ESV** 621/1

29.06.92	Gez. Brause	Druck	<i>Zwan</i>
----------	-------------	-------	-------------

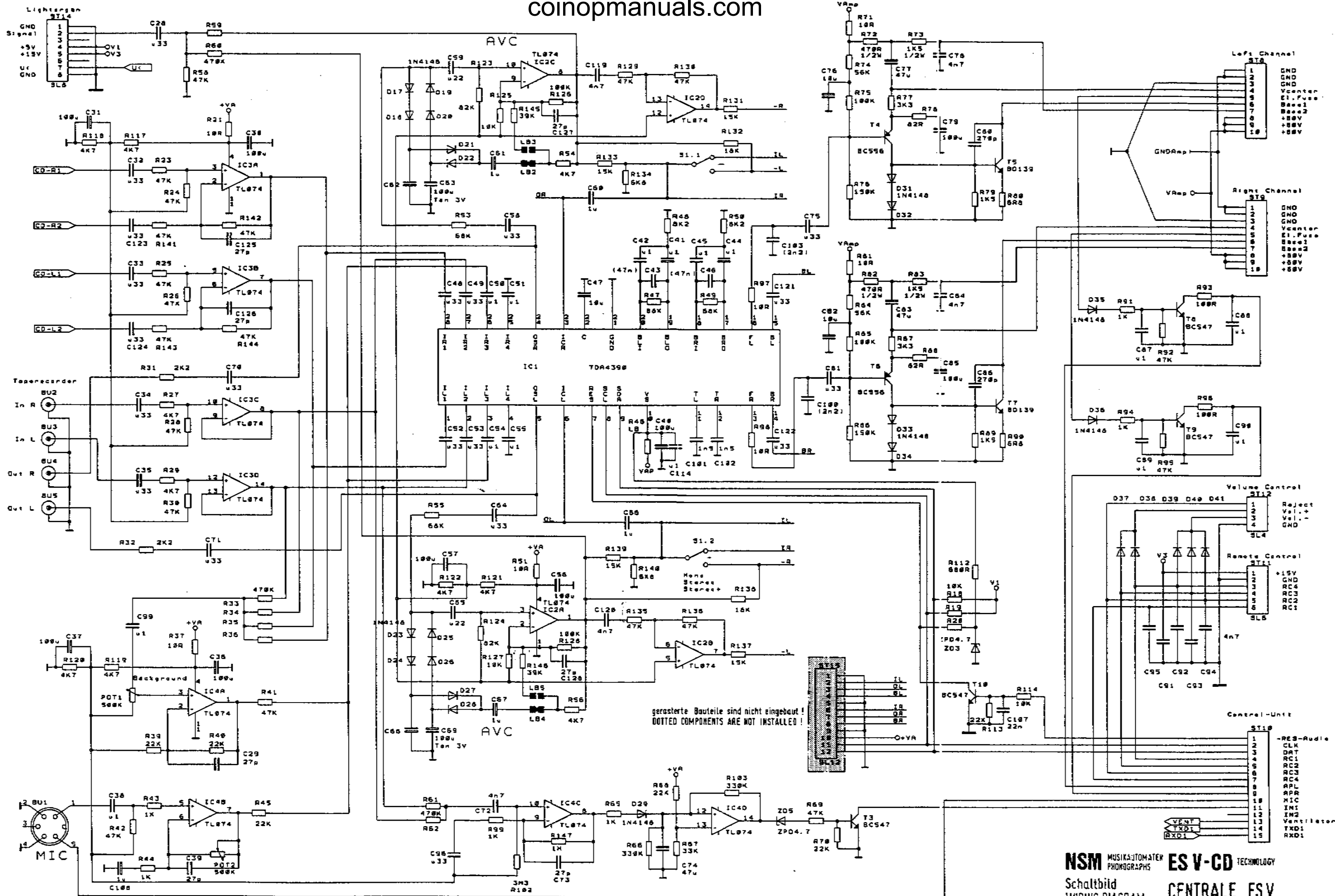

gerasterte Bauteile sind nicht eingebaut!
DOTTED COMPONENTS ARE NOT INSTALLED!

176 392 / 176 351 / 176 513 / 176 609
176 393 / 176 352 / 176 514 / 176 610 / 176 598
176 394 / 176 353 / 176 515 /
07/92

AUDIO

ÄNDERUNGEN IM SINNE DES TECH. FORTSCHRITTES VORBEHALTEN,
JEDOCH KEINE NACHRUFPLICHT!
SUBJECT TO TECHNICAL MODIFICATION WITHOUT OBLIGATION
TO MODIFY EQUIPMENT ALREADY DELIV. RED!

NSM MUSIKAUTOMATEN PHOTOGRAFISCHES ES V-CD TECHNOLOGY
Schaltbild WIRING DIAGRAM CENTRALE ES V

29.06.92 Braunschweig

UNIT DESCRIPTION

OUTPUT STAGE

FOR NSM-PHONOGRAPHS

ES V-CD TECHNOLOGY

to
Technical Information, Assy

176 393	THE PERFORMER GRAND II
176 352	THE WIZARD / OLD FASHION WIZARD
176 514	THE PERFORMER CLASSIC
176 610	CD HIDE-AWAY II
176 598	FIREBIRD II

NSM

Aktiengesellschaft
Saarlandstraße 240
6530 Bingen am Rhein

7

Page 701-704

Output Stage

The output stage is designed without induction coils or transformer and is therefore ironless. At full volume the music power is 200 W per channel when connected to a 2-ohm loudspeaker impedance.

Functions such as power supply, signal path and settings as well as repair aids are described in detail in the unit description "CENTRAL UNIT".

SPARE PARTS LIST

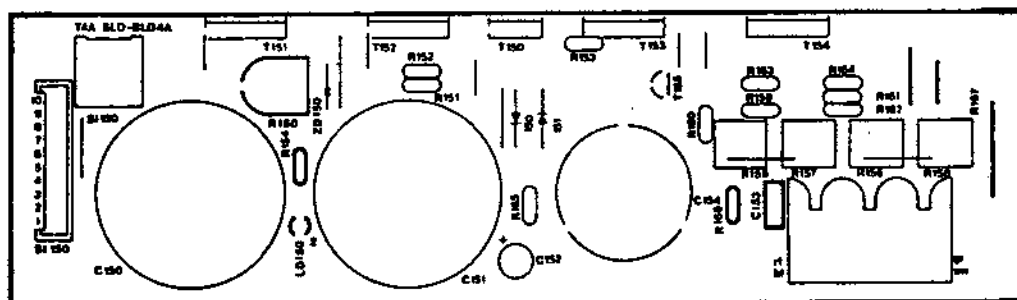

SPARE PARTS LIST

POS.	PART-No.	DESCRIPTION	DATA	QTY
	171 701	<u>OUTPUT STAGE, ASSY</u>	<u>50 Hz</u>	1
SI 150	225 036	FUSE	T 4 A träge	1
	225 747	CAP		1
	171 696	CHASSIS		1
	171 881	VENTILATOR, ASSY		1
	171 699	AIR VANE		1
	222 485	TEMPERATURE CONTROLLER		1
	171 704	CLAMP, STAMPED		2
	171 758	HOLDER		2
	250 177	COOLING PLATE		2
	171 759	COVER		2
<u>CB-OUTPUT STAGE</u>				
	225 422	TERMINAL BAR	3 prongs	1
ST 150	225 654	PIN PANEL	10 prongs	1
	225 746	FUSE HOLDER	sw	2
D150, 151	221 115	SI-DIODE	1 N 4004	2
ZD 150	221 650	SI-ZENER-DIODE	ZPD 33	1
LD 150	221 466	LUMINESZENZ-DIODE	CQY 65	1
T 150	221 883	SI-TRANSISTOR	NPN BD 239 B	1
T 155	221 459	SI-TRANSISTOR	PNP BD 256	1
T151, 152	221 886	DARLINGTON-TRANSISTOR	NPN BDW 83 C	2
T153, 154	221 902	DARLINGTON-TRANSISTOR	PDP BDW 84 C	2
C 153	220 333	MET.-CAPACITOR	0,22 µF 63 V	1
C 152	220 162	LYTIC	10 µF 63 V	1
C 154	220 396	LYTIC	4700 µF 50 V	1
C150, 151	220 436	LYTIC	4700 µF 63 V	2
R 166	221 094	RESISTOR	2,7 Ohm 1/4 W	1
R152, 153	221 096	RESISTOR	56 Ohm 1/4 W	2
R 151	231 154	RESISTOR	750 Ohm 1/4 W	1
R 159-162	221 029	RESISTOR	1 KOhm 1/4 W	4
R 164	221 032	RESISTOR	2,7 KOhm 1/4 W	1
R 163	221 034	RESISTOR	4,7 KOhm 1/4 W	1
R 154	221 625	RESISTOR	5,6 KOhm 1/4 W	1
R 165	221 604	RESISTOR	22 KOhm 1/4 W	1
R 167	221 276	WIRE WOUND RESISTOR	470 Ohm 1 W	1
R 155-158	221 275	WIRE WOUND RESISTOR	0,22 Ohm 7 W	4
R 150	221 305	TRIMMER RESISTOR	2,2 KOhm 0,1 W	1

Thermoschalter
TEMPERATURE SWITCH

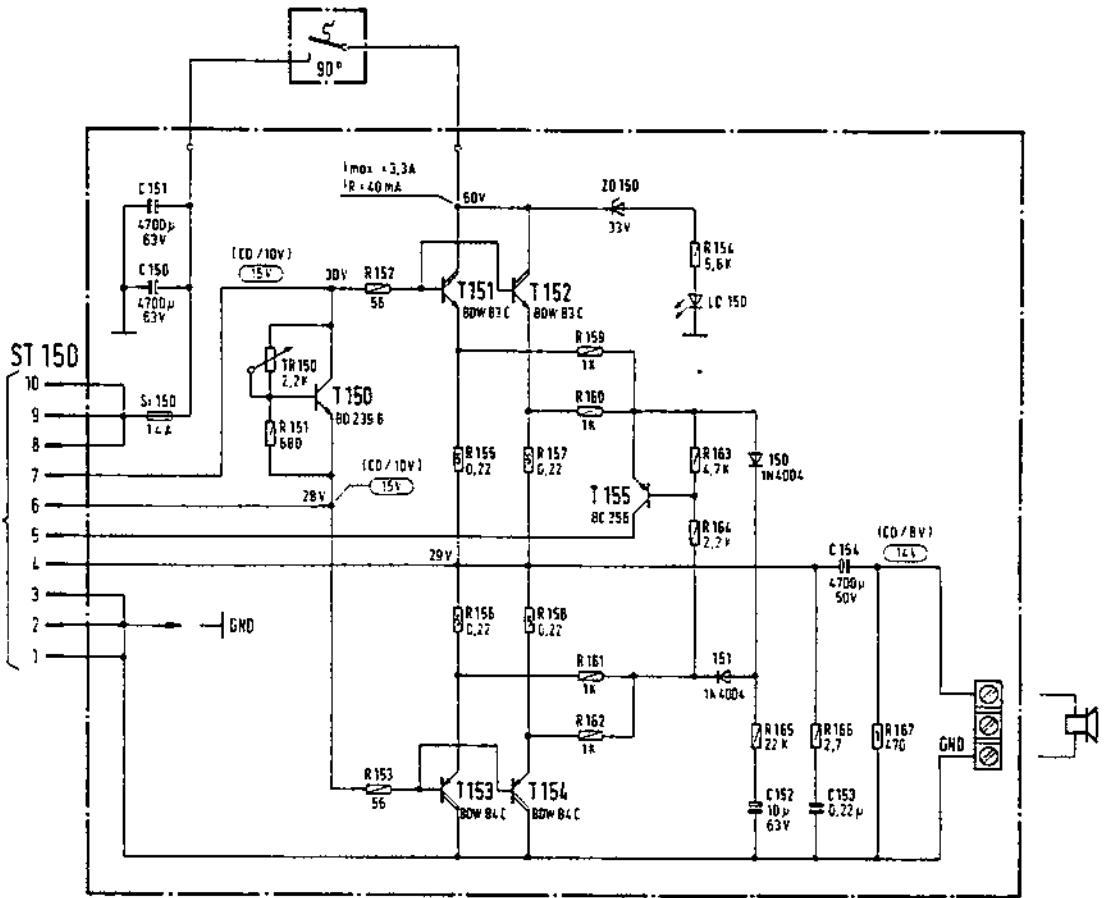

CENTRALE
linker Kanal Stecker ST 8
LEFT CHANNEL PLUG ST 8
rechter Kanal Stecker ST 9
RIGHT CHANNEL PLUG ST 9

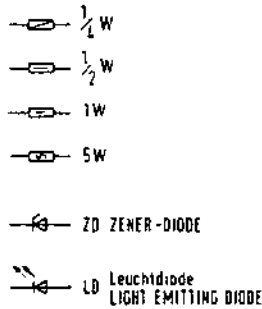

NF-Pegel bei 1 KHz, Lautstärksteller auf max
 Höhen und Bässe max., ohne (CD/with) AVC gemessen mit elektron. Voltmeter.
 Gleichspannung gemessen mit Voltmeter Ri = 10 M.Ω
 AC SIGNAL VOLTAGES AT 1000 cps, VOLUME CONTROL TO MAX TREBLES AND
 BASSES MAX., WITHOUT (CD/WITH) AVC MEASURED WITH ELECTRONIC VOLT-METER.
 DC VOLTAGES MEASURED WITH VOLTMETER Ri = 10 MEG OHMS.

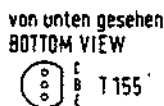
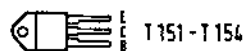

Alle Sicherungen träge!
ALL FUSES SLD BLO!

Sicherungen nur durch solche mit gleichen Werten ersetzen!
REPLACE FUSES ONLY BY THOSE OF THE SAME VALUE!

ÄNDERUNGEN IM SINNE DES TECHN. FORTSCHRITTES VORBEHALTEN,
JEDDOCH KEINE NACHRÜSTPFLICHT!

SUBJECT TO TECHNICAL MODIFICATION WITHOUT OBLIGATION
TO MODIFY EQUIPMENT ALREADY DELIVERED!

NSM MUSIKAUTOMATEN PHONOGRAPHS **ES V-CD** TECHNOLOGY

Schaltbild Endstufe
WIRING DIAGRAM OUTPUT STAGE

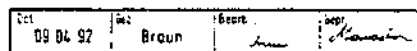

UNIT DESCRIPTION

CD CHANGER

FOR NSM-PHONOGRAPHS

ES V-CD TECHNOLOGY

to
Technical Information, Assy

176 393	THE PERFORMER GRAND II
176 352	THE WIZARD / OLD FASHION WIZARD
176 514	THE PERFORMER CLASSIC
176 610	CD HIDE-AWAY II
176 598	FIREBIRD II

NSM
Aktiengesellschaft
Saarlandstraße 240
6530 Bingen am Rhein

8

Page 801-814 / 821-822

INDEX

- 1 PICKUP FUNCTION**
 - 1.1 Transport**
 - 1.2 Pull holder**
 - 1.3 Return holder**
 - 1.3.1 Leave CD on the player**

 - 2 PICKUP DRIVER**
 - 2.1 Lift control**
 - 2.2 Grip control**

 - 3 CD-PLAYER**

 - 4 PCB DECODER BOARD**

 - 5 MAGAZINE**

 - 6 CD CHANGER 100, test, set, adjust**
 - 6.1 GENERAL INFORMATION**
 - 6.2 MAGAZINE**
 - 6.3 PLAYING UNIT**
 - 6.4 LIFT**
- Spare parts lists**

1 PICKUP FUNCTION

The pickup serves to transport the CD's between the magazines and the player.

1.1 Transport

The lift is moved via a stepping motor controlled by the microprocessor of the control unit. The distance between 2 CD slots is 8 motor steps (1 counter step of a light barrier).

During the run the light barrier OPTSP, which is directly connected to the drivewheel, checks the motor's position every 4 steps. Stepping errors are immediately recognized and displayed with "Er 73" on display 3.

Together with the light barrier OPEND the end position of the lift is verified. Should a mistake appear here (signal too late or too early) the display shows "Er 74".

1.2 Pull Holder

With both grip levers, brought into lock position by CD motors MOGRL for left and MOGRR for right, the CD holders with their CD's are pulled out of the magazine. The light barrier OPPUM reports the correct position of the CD holder in the pickup unit.

If there is no report 2 sec. after switching on the motor, the display will show "Er 71" for the left and right magazine.

1.3 Return Holder

To return a CD holder to its magazine, either motor MOGRL for the left magazine or MOGRR for the right magazine is switched on in the opposite direction.

Light barriers OPGRL or OPGRR report the end position of the grips.

If the report does not appear within 2 sec. after switching on the motor, the display shows "Er 71" for pull holder or "Er 72" for return holder.

1.3.1 Leave CD on the player

If you want the CD to remain on the player after it finishes playing, the solder bridge LB3 on the pickup driver board must be connected.

If the cabinet switch is pulled out (call the service and programming mode), the tray with the CD is returned to its magazine.

2 PICKUP DRIVER

2.1 Lift Control

With output port of IC1 the microprocessor of the control unit controls the switch transistors T 1-4 via drivers T 6-10. These drive the unipolar coil of the stepping motor (ST4, Pin 1-6). Using signal OPSTP (ST 5, Pin 2) the microprocessor controls the position of the motors. Together with signal OPEND (ST 3, Pin 8) the end position of the lift is reported via input port of IC 3.

2.2 Grip Control

Both of the grip motors (MOGRL for the left magazine and MOGRR for the right magazine) are driven from the double motor bridge IC 4 via the output port of IC 2.

While pulling a CD from the magazine the signal OPPUM (ST 3, Pin 7) reports the end position of the CD holder in the pickup to the microprocessor of the control unit.

While returning the CD it recognizes the end position of the grips via signals OPGRL (ST 3, Pin 5) for left and OPGRR (ST 3, Pin 6) for right.

3 CD PLAYER

The disc-player "CDM 4" contains the components laser diode, play motor, radial motor, and focus unit.

It reads the data from the CD. (The density is xxx bits per inch?).

4 PCB DECODER BOARD

The components servoprocessor, decoder, digital filter, DA converter and NF output driver are combined on the decoder board. The digital information read from the CD are transformed into the corresponding audio signal for the amplifiers.

5 MAGAZINES

2 equal magazines that are equipped with 50 CD holders each are in the CD changer. With CD holders it is to play 5-inch CD's.

The magazine can be fold out by pushing the corresponding release button to the center of the changer. The magazine can be taken out by pushing the corresponding button to the outside of the changer.

Equipping with or changing CD's can be done simply by taking out the respective CD holders, inserting the new CD into the holder and pushing it back till it locks in the magazine. For the transportation of a equipped magazine just pull the red transportation fixture of the lift axle through the center holes of all CDs in the magazine.

**6 CD CHANGER 100,
test, set, adjust**

6.1 GENERAL INFORMATION

Please note the illustration of the CD changer on the last page and the informations about the command P 157 in the chapter "Programming of the phonograph" regarding the following text. After exchanging units their functions must be checked and, if needed, certain adjustments must be made.

To exchange the playing unit the CD changer can remain in the phonograph. But to remove or install the lift the changer has to be removed from the machine; tests and adjustments are only possible at a bench tester or at the machine with appropriate extensions!

Take care that the changer is set down on supports so that the board disc (12) or the main axle (14) which protrude from the cabinet floor are not pushed inside. Otherwise the board disc will jam the gear (2); a displaced axle changes the position of the upper distance sleeve so that the lift drives against it and blocks!

With help of the command P 157 (in the service and programming mode) "Test CD Changer" the grips can be moved left or right with Keys "4"/"5" or "6"/"5" and the lift can be moved up or down with key "2"/"8". With key "1" the CD player can be started and stopped.

For fine adjustments of the lift position the lift can be moved with Key "3" (+) or "9" (-) one motor step at a time (equals about 0,5 mm height difference) either up or down.

The distance between two magazine slots is 8 motor steps (or 1 step. of the light barrier).

In the displays the present status of the respective opto mask and the time in seconds during which the lift position is held are shown.

6.2 MAGAZINE

The magazines are supported by height-adjustable studs in fold-in and locked position. Changing the height setting can be necessary when the lift is exchanged; setting see Pt. 6.4 "Lift".

6.3 PLAYING UNIT

To exchange the playing unit with CD player

- remove both magazines
- pull lift up on gear belt
- remove 4 screws M4
- carefully (!) pick up playing unit, watch balance washers under cabinet
- open plug connections
- installation of playing unit in opposite sequence
- function test:
 - choose CD, check if CD is securely clamped in play position.
 - further tests see Pt. 6.4 "Lift".

6.4 LIFT

To exchange the lift as well as to check and adjust the optical coupling devices (light barrier) of the CD changer, completely remove the CD changer, disconnect cables, remove rear wall.

- From the rear side of the machine pull lift (04) up by the gear belt (02), interrupt connection between lift and gear belt by unscrewing the gear belt lock (03).
 - Pull out plug of connecting cable (06).
 - Remove board disc (12) after removal of washer.
 - Pull lower distance disc(s) (13) and rubber gasket of main axle (14) from cabinet floor upwards.
 - Push main axle down until lower rubber gasket can be removed.
 - Remove lift; mount exchange lift in opposite sequence.
 - Function test, basic setting; CD changer must be completely connected to operate either with extensions to phonographs or a bench tester:
 - After entering the service mode call the command P 157. On display 2 the corresponding number of the test "F8" is displayed. Now the different functions can be tested according to the scheme shown below.
- The control is done via the keys of the operating panel.

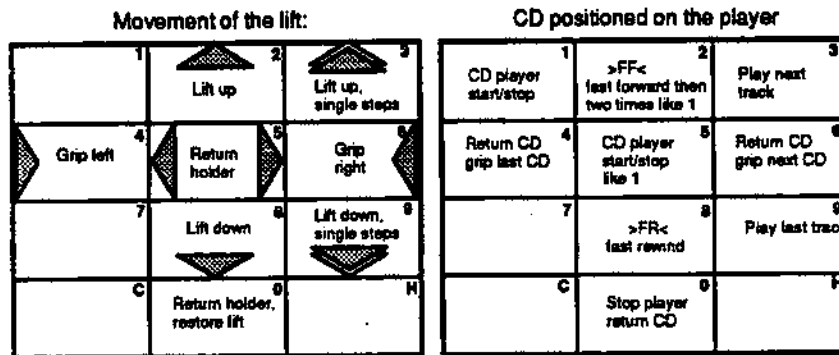

The state of the light barriers are displayed on the displays 1 and 3.

Display:

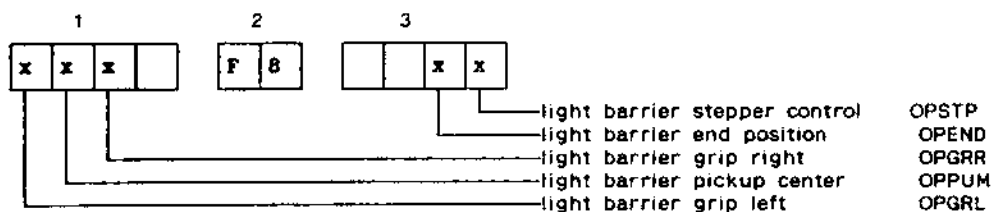

Meaning of displays: light barrier lit up = "0", darkened = "1".

- The basic setting occurs in parked position at magazine slot 25/75. Drive pick-up to this position with keys "2" or "8".
The lift is held after each function in this position for 2 sec.; with key "0" for 10 sec.
- Drive cassette in and out with Keys "4"/"5" or "6"/"5".
Check function for smooth movement.
The respective grip lever must fall into the cassette without hindrance!
- To adjust lift height loosen belt lock and move up or down; then tighten screws!
- Move lift down one motor step (about 0,5 mm height difference) with key "9" (-); same test for smooth movement.
- Drive to normal park position with key "0" and with key "3" (+); switch lift one motor step above normal position. Same check for smooth movement.
- Set magazine height: If magazine slots do not align with lift, then adjust lift only to one magazine at first. After that the other magazine is adjusted with support screw (11/15) to the correct height.
- The light barrier (08) on the step motor must be in parked position 25/75 in the center of the light barrier OPSTP (09) (status display of OPSTP in display = "1"). If necessary, loosen screw on hexagon bolt and set PCB with light barrier to center of mask.
- To adjust light barrier OPEND (05) lift must be driven down to bottom. Drive lift upwards manually or by pressing Key "3" 4 times one half opto step; the mask (16) must release OPEND (05) when OPSTP (09) opens the light mask, displayed by "0" on digit 1. Adjustment is done by shifting of light mask angle (16) of OPEND, displayed by transition of "0" to "1" or "1" to "0" (shown on digit 2).
- Leave the service mode by pressing the housing switch.
- Select CD in normal play mode. In the parked position of the playing position the lift must have a gap to the lower end position.
- The distance between a cassette and the clamping dish should be at least 1 mm during a gripping procedure. So that the clamping dish can be magnetically attracted, the decorative cover must be in place.
- The CD must run without touch and grinding sounds when in a suspended position.
To test the function get cassette with CD from magazine by pressing the corresponding keys and place it on CD player in play position.
Turn on CD player with key "1". After test with key "1" or any of the other function test keys turn off CD player. The clamping dish must clamp down the CD exactly in center.
- Check function of fork light masks OPGRR, OPGRL, OPPUM as per test "F8". The respective light mask must cover the light barrier in its entire breadth (when status display "1" is shown) and may not touch it physically.

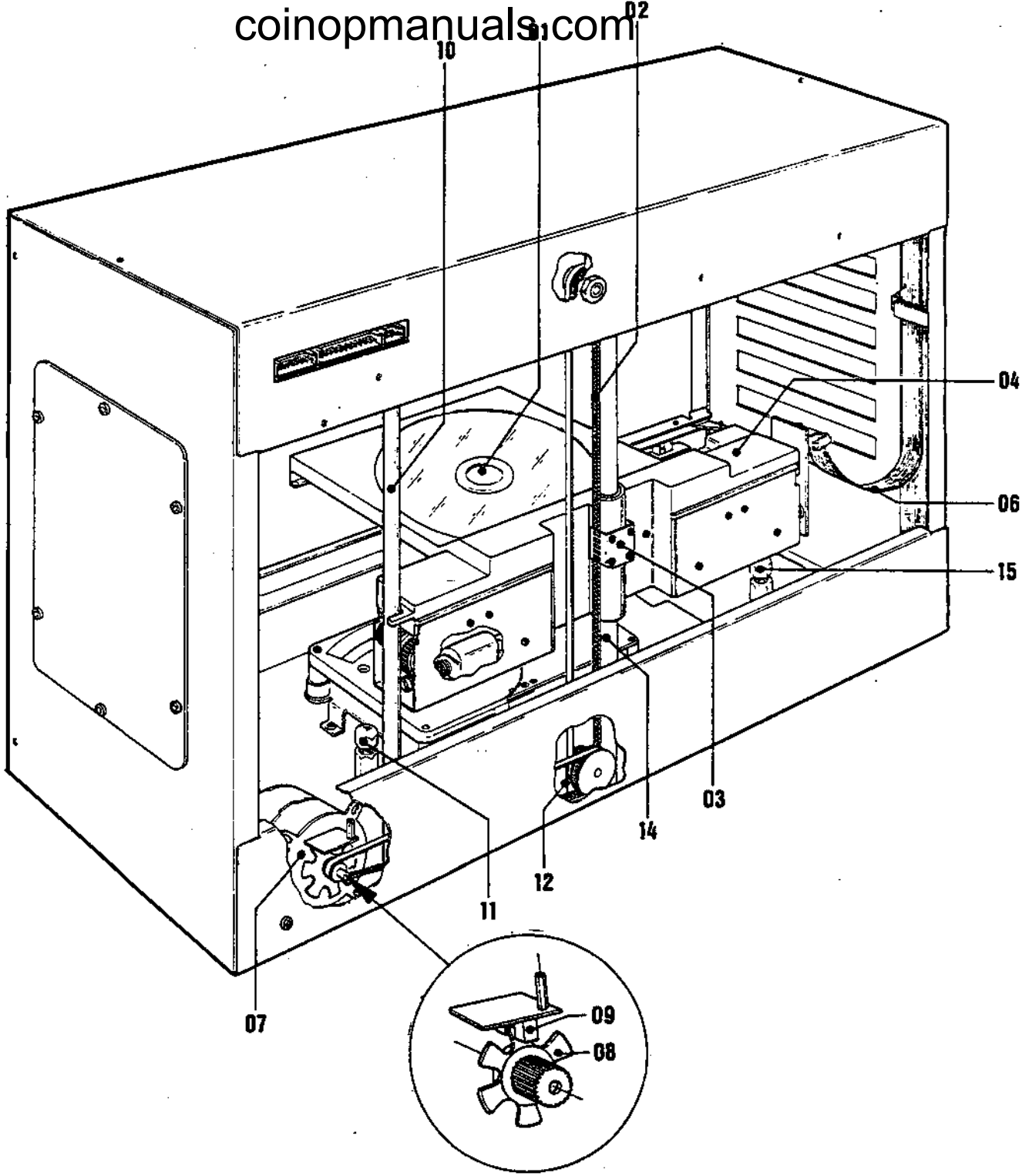

CD CHANGER, COMPL.

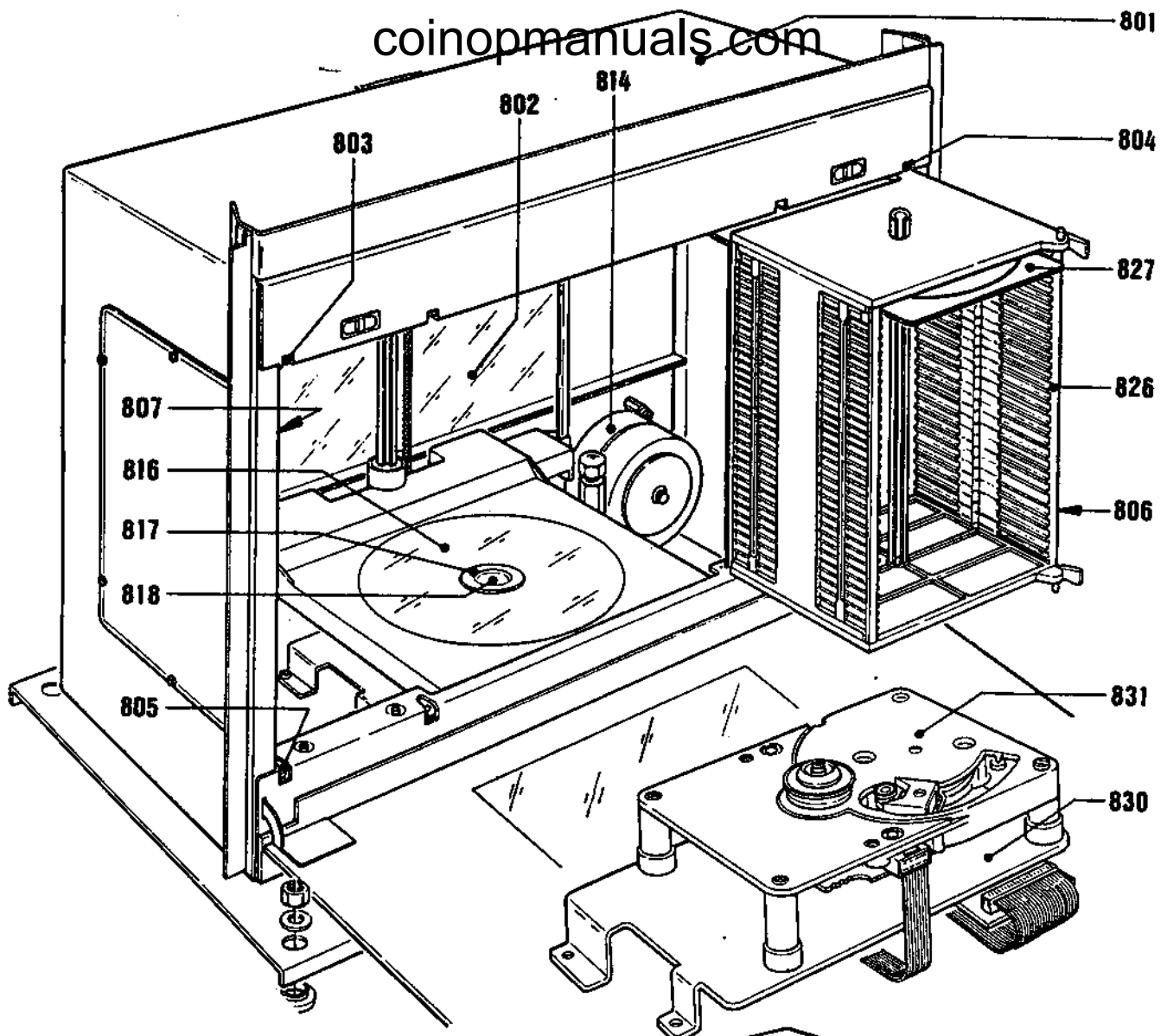

810

SPARE PARTS LIST

POS.	PART-No.	DESCRIPTION	DATA	QTY
see Page 100/...		<u>CD-CHANGER 100 -CDM 4-</u>	STANDARD	1
				1
801	175 733	CABINET, welded		1
802	175 730	REAR WALL		1
803	175 913	CLOSING LEDGE, UPPER, LEFT, welded		1
804	175 914	CLOSING LEDGE, UPPER, RIGHT, welded		1
805	174 294	CLOSING LEDGE, LOWER, LEFT		1
806	174 295	CLOSING LEDGE, LOWER, RIGHT		1
807	206 655	CONNECTION AXLE		2
808	173 538	SCREW SLEEVE, ASSY		2
	173 526	BOARD WASHER		2
809	173 522	STEP WHEEL, MOUNTED		1
	173 521	WASHER 48		1
810	176 134	AXLE		2
811	173 530	BELT WHEEL, MOUNTED		1
812	206 644	BELT	Typ MXL 195	1
813	206 643	BELT	Typ MXL 298	1
814	176 299	STEPPER MOTOR, ASSY		1
815	175 735	LIFT, ASSY		1
	175 783	LIFT, welded		1
816	175 785	PROTECTIVE SCREEN		1
817	175 787	CD-GUIDE		1
818	175 789	COVER		1
819	175 772	MOTOR, ASSY		2
820	175 762	GEAR, MOUNTED		2
821	206 902	BELT	Typ 30 S 2 M 426	2
822	176 298	HOLDING PLATE, riveted		1
823	206 975	DAMPING		1
824	176 293	LEVER		1
825	176 317	BRACKET		1
	173 491	MAGAZINE, LEFT, MOUNTED	(without Cassette)	1
826	173 499	MAGAZINE, RIGHT, MOUNTED	(without Cassette)	1
827	176 395	CASSETTE CD 120	only 10 piece	-
830	175 887	CHASSIS		1
831	176 725	SERVICE KIT -PLAYER CDM-4		1
	205 846	CLAMP		8
	210 486	CARDBOARD for MAGAZINE		1
	212 542	TRANSPORT DEVICES for CASSETTE and LIFT		2
	176 010	CB-CARRIAGE, ASSY	see Page 813	1
	176 249	CB-STEPPER, ASSY	see Page 813	1
	206 919	CB-DECODER BOARD, COMPLET ONLY		1
	176 384	CB-DRIVER		1
	175 964	TRAILING CABLE		1
	206 943	CABLE HARNESS 1 CDM 4		1
	206 942	CABLE HARNESS 2 CDM 4		1

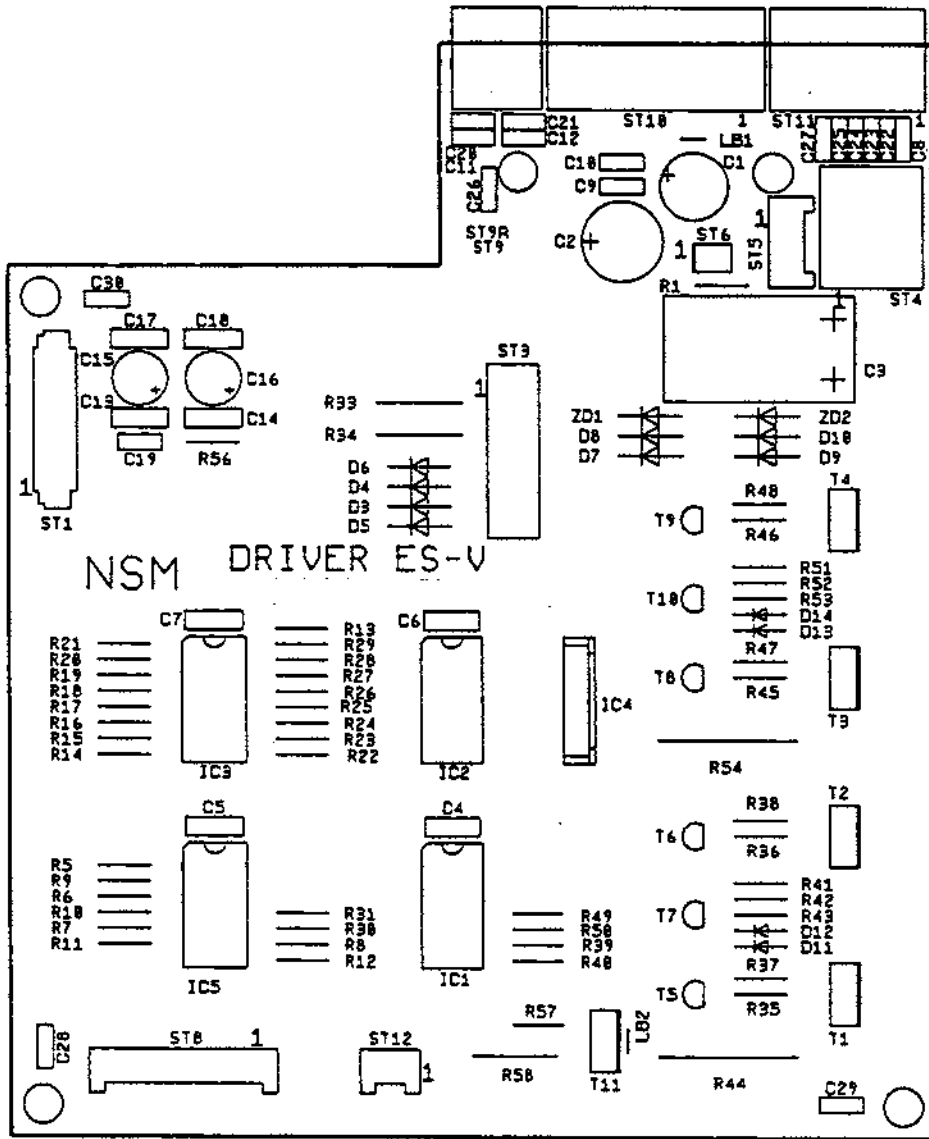

SPARE PARTS LIST

POS.	PART-No.	DESCRIPTION	DATA	QTY
	176 384	CB-DRIVER ES V. ASSY		1
	175 976	COOLING PLATE		1
ST 3	225 912	PIN PLUG	AMP 14 prongs	1
ST 1	225 959	FLAT CABLE PLUG	15 prongs	1
ST 12	225 650	PIN PANEL	2 prongs	1
ST 5	225 651	PIN PANEL	4 prongs	1
ST 8	225 654	PIN PANEL	10 prongs	1
ST 9	225 661	PIN PANEL	4 prongs 90°	1
ST 4	225 662	PIN PANEL	6 prongs 90°	1
ST 11	225 663	PIN PANEL	8 prongs 90°	1
ST 10	225 665	PIN PANEL	12 prongs 90°	1
IC 3	221 763	IC-CMOS	HEF 4021 B	1
IC 5	221 810	IC-CMOS	HEF 4050 BP	1
IC 1,2	221 771	IC-CMOS	HEF 4094 B	2
IC 4	231 303	IC-LINEAR	L 298	1
D 11-14	221 114	SI-DIODE	1 N 4148	4
D 3-10	221 822	SI-DIODE	BA 157	8
ZD 1, 2	231 326	ZENER-DIODE	ZY 24	2
T 5-10	221 757	SI-TRANSISTOR	BC 547 B	6
T 1-4, 11	231 150	SI-TRANSISTOR	TIP 130	5
C 8	220 342	CER.-CAPACITOR	100 pF	1
C 9-12	220 274	CER.-CAPACITOR	330 pF	4
C 4-7	220 344	CER.-CAPACITOR	22 nF	4
C 13, 14,				>
17, 18	220 481	CER.-CAPACITOR	0,1 F	4
C 19	220 231	CER.-CAPACITOR	2,2 nF	1
C 1	220 162	LYTIC	10 µF 63 V	1
C 15, 16	220 493	LYTIC	47 µF 25 V	2
C 2	220 391	LYTIC	220 µF 25 V	1
R 19	221 600	RESISTOR	100 Ohm 1/4 W	1
R 1	221 632	RESISTOR	160 Ohm 1/4 W	1
R 37, 38,				>
47, 48	221 624	RESISTOR	220 Ohm 1/4 W	4
R 42, 43,				>
52, 53	221 029	RESISTOR	1 KOhm 1/4 W	4
R 9-12, 30,				>
57	221 033	RESISTOR	3,3 KOhm 1/4 W	6
R 41, 51	221 607	RESISTOR	6,8 KOhm 1/4 W	2
R 35, 36,				>
39, 45, 46,				>
49, 56	221 035	RESISTOR	10 KOhm 1/4 W	7
R 14-21	221 603	RESISTOR	12 KOhm 1/4 W	8
R 22-29	221 036	RESISTOR	15 KOhm 1/4 W	8
R 5-7, 31	221 604	RESISTOR	22 KOhm 1/4 W	4
R 40, 50	221 618	RESISTOR	24 KOhm 1/4 W	2
R 8	221 048	RESISTOR	100 KOhm 1/4 W	1
R 58	221 685	RESISTOR	3,9 Ohm 1/2 W	1
R 33, 34	221 392	RESISTOR	390 Ohm 1/2 W	2
R 44, 54	221 692	WIRE WOUND RESISTOR	1 Ohm 1 W	2

SPARE PARTS LIST

POS.	PART-No.	DESCRIPTION	DATA	QTY
	176 249	<u>CB-STEPPER, ASSY</u>		1
	231 322	OPTO-COUPLER	LTH-301	1
	225 611	SOCKET	4 prongs sw	1
	173 557	<u>CB-MOTORCONTROL, ASSY</u>		1
	231 322	OPTO-COUPLER	LTH-301	1

SPARE PARTS LIST

POS.	PART-No.	DESCRIPTION	DATA	QTY
	173 636	CABLE HARNESS: LIFT		1
	173 639	CABLE HARNESS: PICK UP - CABLE I		1
	173 641	CABLE HARNESS: PICK UP - CABLE II		1
	173 644	CABLE HARNESS: TRAILING CABLE		1
	151 645	CABLE HARNESS: DECODER CABLE I		1
	173 646	CABLE HARNESS: DECODER CABLE II		1
	173 647	CABLE HARNESS: DRIVER CABLE I		1
	173 648	CABLE HARNESS: DRIVER CABLE II		1
	173 649	CABLE HARNESS: DRIVER CABLE III		1
	173 740	CABLE HARNESS: NF - CABLE		1
	174 185	CABLE HARNESS: SWITCH		1

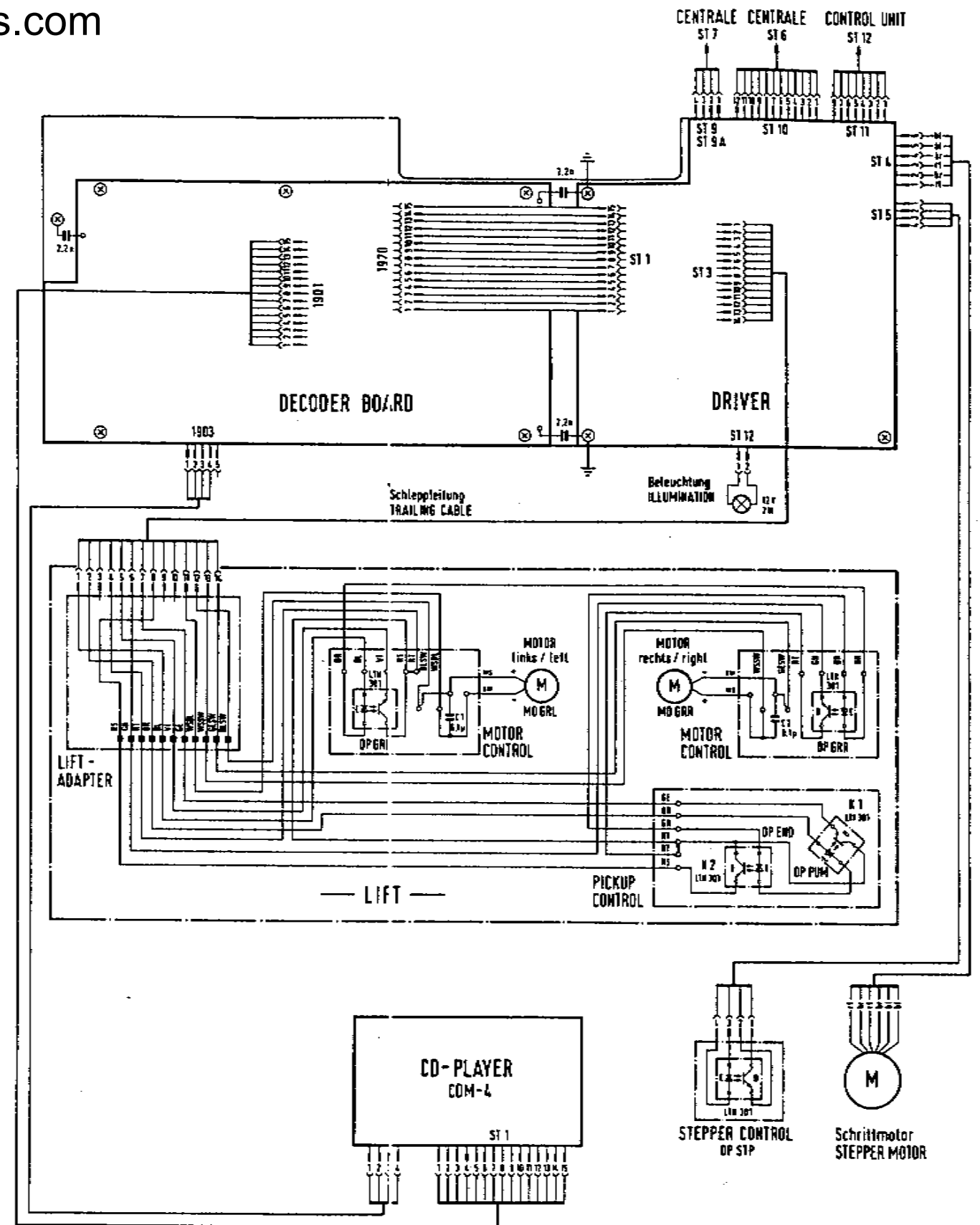

- OP END OP10 END POSITION
- OP GRL OP10 GREIFER LINKS
OP10 GRASP LEFT
- OP GRR OP10 GREIFER RECHTS
OP10 GRASP RIGHT
- OP PUM OP10 PICKUP MITTE
OP10 PICKUP CENTER
- OP STP OP10 STEPPER CONTROL
- MD GRL MOTOR GREIFER LINKS
MOTOR GRASP LEFT
- MD GRR MOTOR GREIFER RECHTS
MOTOR GRASP RIGHT

Farbspiegel
COLOR CODE

we	weiß	white
bl	blau	blue
br	braun	brown
ge	gelb	yellow
gr	grün	green
gr	grau	gray
or	orange	orange
ro	rot	red
rl	rot	red
sw	schwarz	black
si	silber	metal

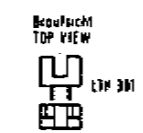

Farbangaben ohne Gewähr
COLOR INDICATION WITHOUT WARRANTY

ÄNDERUNGEN IM SINNE DES TECHN. FORTSCHRITTES VORBEHALTEN,
JE DOCH KEINE NACHRUFPLICHT!
MODIFY TO TECHNICAL MODIFICATION WITHOUT OBLIGATION
TO MODIFY EQUIPMENT ALREADY DELIVERED!

NSM MUSTRAUTOMATEN PHONOGRAPHS **ES V-CD** TECHNOLOGY

ELEKTROPLAN CD-WECHSLER
OPERATING SCHEME CD-CHANGER

821

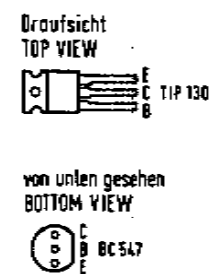
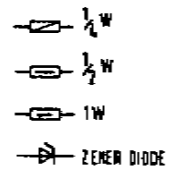
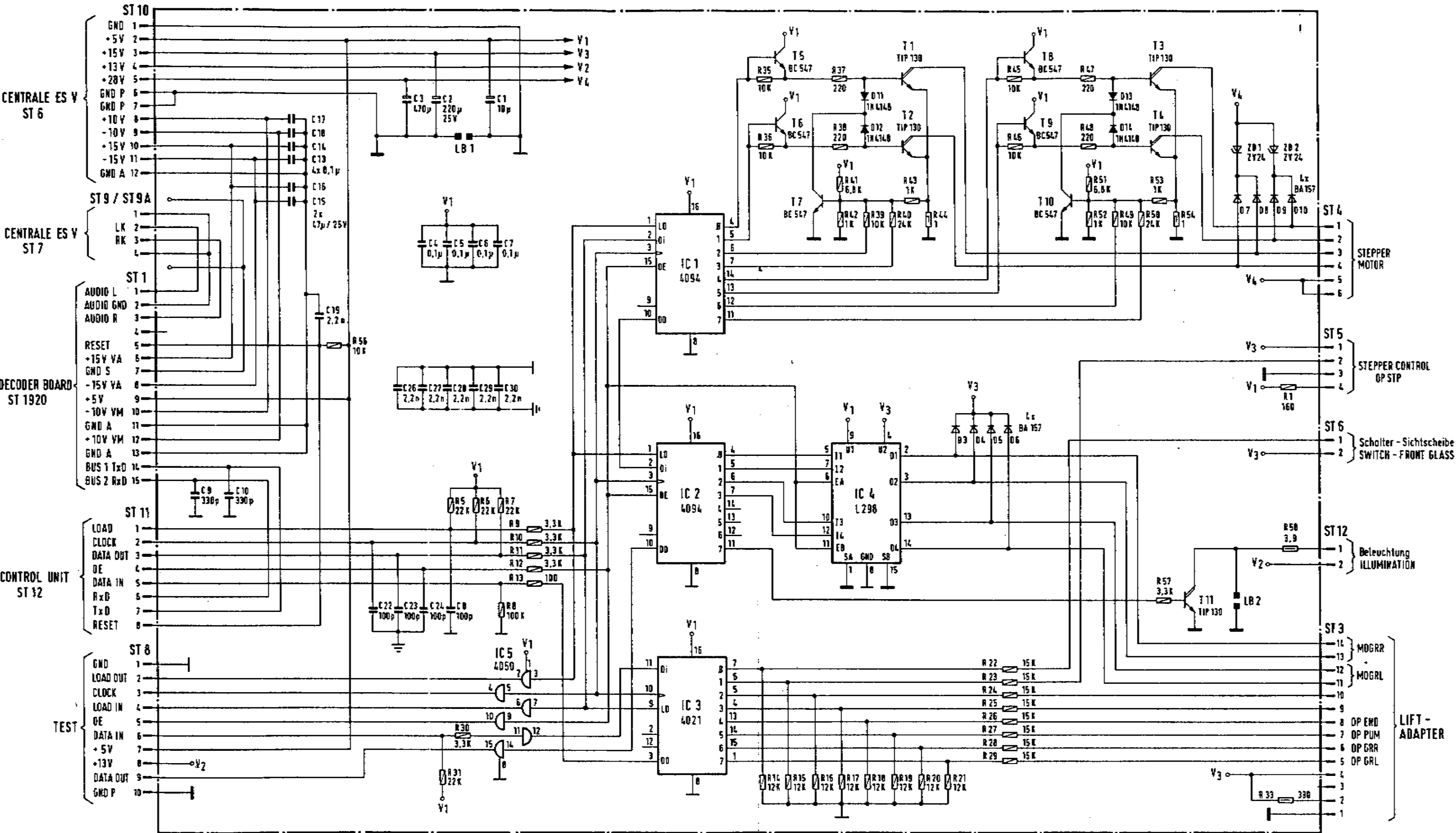

- DP END OPTO END POSITION
- DP GRL OPTO GREIFER LINKS OPTO GRASP LEFT
- DP GRR OPTO GREIFER RECHTS OPTO GRASP RIGHT
- DP PUM OPTO PICK UP MITTE OPTO PICK UP CENTER
- DP STP OPTO STEPPER CONTROL
- MD GRL MOTOR GREIFER LINKS MOTOR GRASP LEFT
- MD GRR MOTOR GREIFER RECHTS MOTOR GRASP RIGHT

ÄNDERUNGEN IM SINNE DES TECHN. FORTSCHRITTES VORBEHALTEN, JEDOCH KEINE NACHRÜSTPFLICHT!
 SUBJECT TO TECHNICAL MODIFICATION WITHOUT OBLIGATION TO MODIFY EQUIPMENT ALREADY DELIVERED!

NSM MUSIKAUTOMATEN **ES V-GD** TECHNOLOGY
 PHONOGRAPHS **DRIVER**

Schaltbild
 WIRING DIAGRAM

176 392 / 176 351 / 176 513 / 176 609
 176 393 / 176 352 / 176 514 / 176 610 / 176 592
 176 394 / 176 353 / 176 515

Rev. 19.03.92
 Gez. Braun
 Gezeichnet
 Geprüft

UNIT DESCRIPTION

TITLE INDICATION III

FOR NSM-PHONOGRAPHS

ES V-CD TECHNOLOGY

to

Technical Information, Assy

176 393

176 352

176 514

176 598

176 705

THE PERFORMER GRAND II

THE WIZARD /

OLD FASHION WIZARD

THE PERFORMER CLASSIC

FIREBIRD II

THE PERFORMER WALL

NSM

Aktiengesellschaft
Saarlandstraße 240
6530 Bingen am Rhein

9

Page 901-913

1 FUNCTION

1.1 PCB Title display

The PCB is connected to the serial interface and +5 V of the control unit via ST 1. +15 V and +14 V are also conducted via ST 1.

The constant voltage of +15 V supplies motors and opto couplers.

Shiftregister IC 2 is the output port for motor driver IC 3, which controls the motor for stacker movement (MO MOV) and the gripper motor (MO GR).

Shiftregister IC 1 is the input port for opto couplers and push buttons.

Light barriers GRL and GRR control the endposition of the gripper (carrier).

MOV1, MOV2 and MOV3 supervise various positions during the stacker movement. Any blocking will be recognized and displayed by error code Er 9x.

Pushbuttons TL and TR in the PCB are service keys for moving title holders.

They are identical with pushbuttons (<-->) and (-->) on the front of the phonograph.

1.2 Movement of title holders

By pushing the keys "left" respectively "right" two title holder will be moved into the corresponding direction.

A complete movement consists out of following phases: If i.e. the key "left" is pushed, at first the position of the gripper will be checked and -if required- the front gripper positioned in front of the right hand stack. Both stacks are level. Now the right stack moves to the front while the left one moves back simultaneously until the grippers enter the carrier slots of the corresponding title holders. Then the grippers move the title holder to the other side. In the final position the right hand stack will be moved forward while the left hand stack will be moved backward until they are level. The grippers will be brought back to their starting position. In case of a limitation of selectable CD's via service step P042 only the corresponding title holders will be shown. A movement to the right beyond the highest cover number as well as to the left below cover number 1 is not possible.

1.3 Exchange of defective title holders

When defective title holders can still be driven to the front by the motor, the exchange of the holder should be performed there.

For removal, the center of the title holder has to be bent slightly forward until it jumps out of the top guide. The insertion of the new title holder works accordingly.

1.4 Jammed or dislocated title holders

When the transportation by motor is impossible due to jamming, all title holders in front of the jamming location have to be removed. After correcting the problem the title holders have to be inserted in the same sequence (Fig. 1).

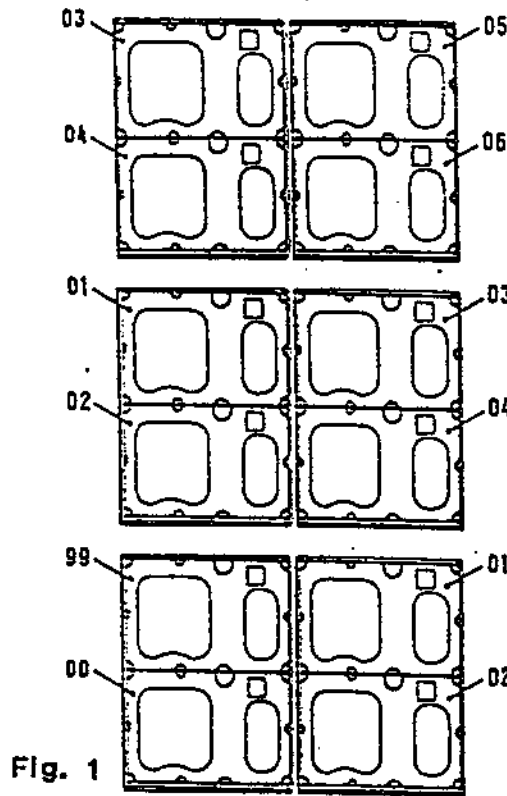
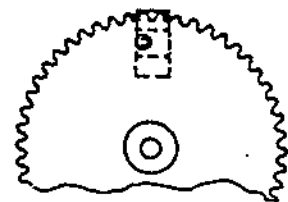
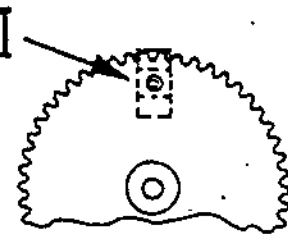
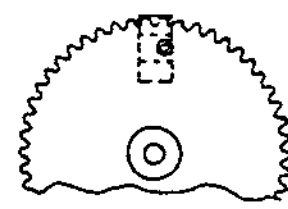

Fig. 1



view from under neath

Fig. 2

1.5 Insertion of all title holders (Synchronization)

When all title holders are removed and the motor has turned, the synchronization has to be readjusted. During insertion of the title holders it is important, that the pin of the counter wheel is positioned exactly in the center of the opto coupler "sync" (Fig. 2/1, 3/1). The belt drives for the title holders (Fig. 3/II) have to be in their end position. When this is not the case, one of the pushbuttons ← → or the service button TL/TR has to be used, until position I and the end position are reached.

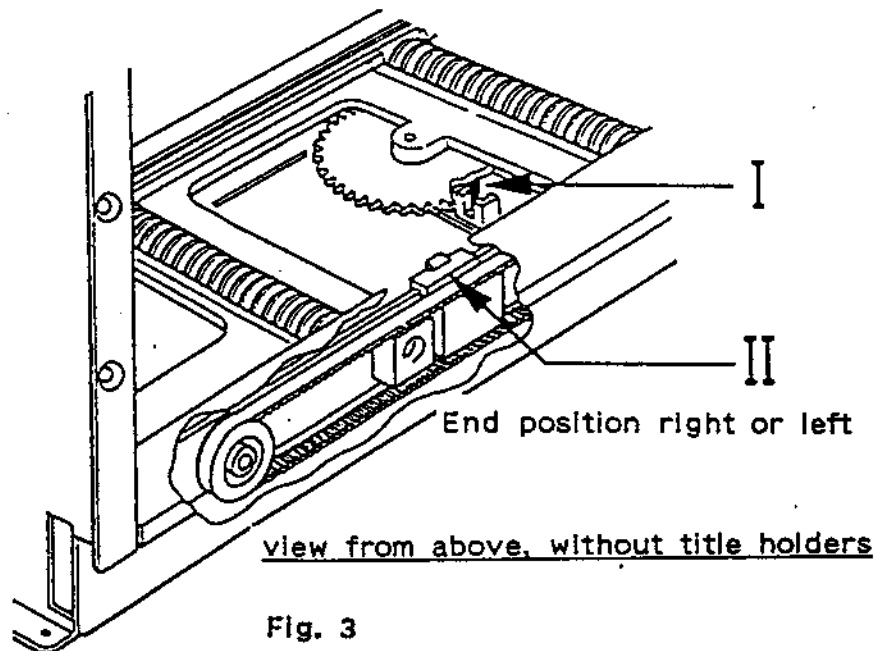

view from above, without title holders

Fig. 3

Now the synchronization has the correct relation to the position of the title holders. The title holders have to be inserted into the worm drives starting from the rear end. In order to do this the title holder has to be bent slightly forward in the center until it fits in the guide. It should be started at the left rear end with "53" (see Fig. 4) then "55", "57" etc until "01"; on the right side it starts with "51", the "49", "47" until "03".

Sequence of title holders (for synchronization)

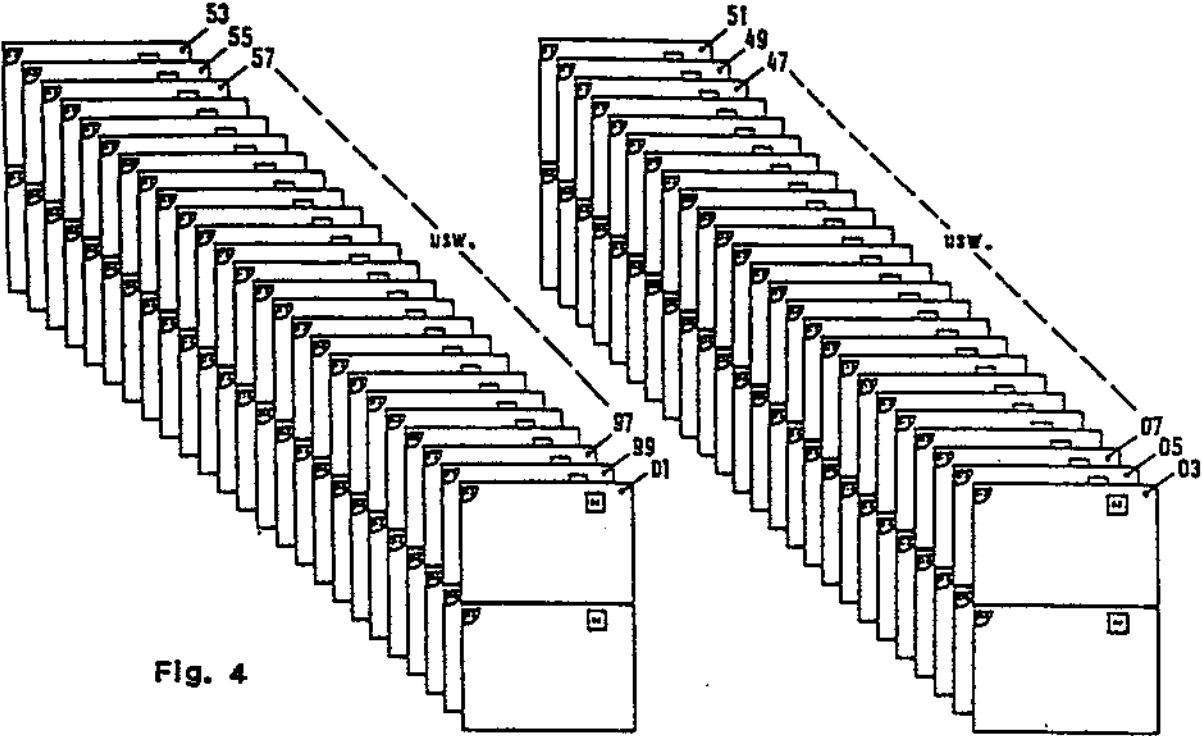

Fig. 4

NOTE! Special care has to be taken during insertion that the first holder has to be inserted into to last slot of the worm drives and the next into the following slot directly in front. If one slot is accidentally skipped, all following title holders have to be removed again.

2 SERVICE

2.1 Operation tests

Service-program-step P60, input test "F2" allows testing of IC1 inputs, port 6. The result is shown on display 3:

The switching position of any give opto couplers is shown on the first digit from the right "0" = closed, "1" = open

The opto coupler is shown on the second digit from the right

Gripper opto

"0" = GRL,

"1" = GRR.

Switching wheel opto

"2" = MOV1,

"3" = MOV2,

"4" = MOV3.

Counting wheel opto

"5" = SYNCHRON.

Directional pushbuttons

"6" = TL,

"7" = TR.

The port number is shown on the third digit from the right.

"6" = Port 6 on IC 1

SPARE PARTS LIST

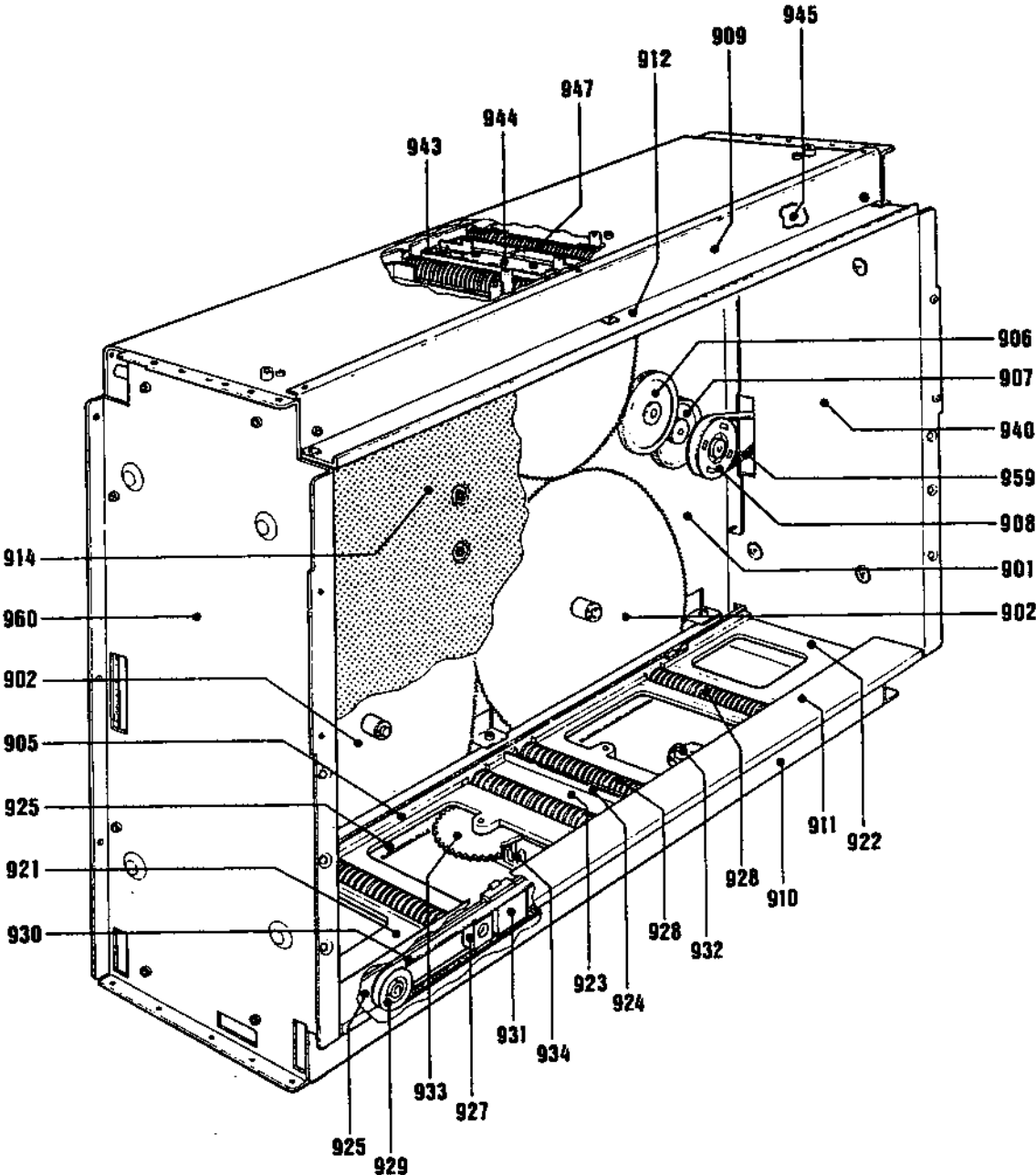

SPARE PARTS LIST

POS.	PART-No.	DESCRIPTION	DATA	QTY
900	176 730	<u>CD-TITLE INDICATION III, ASSY</u>	(with Title Holder)	1
901	174 917	CABINET PLATE, STAMPED		1
	206 100	PLASTIC BEARING	STAR-NYLINER	4
902	174 753	TOOTHED WHEEL	Z = 160	4
903	174 876	SHIFTING WHEEL		1
904	174 929	CB-SHIFTING WHEEL, ASSY		1
905	174 799	GUIDE		1
906	174 886	GEAR WHEEL	Z = 58	1
907	174 875	GEAR WHEEL	Z = 48	1
908	174 878	BELT WHEEL	Z = 52	1
	174 879	WASHER		1
909	174 848	COVER, UPPER		1
910	174 847	COVER, LOWER		1
911	174 900	TRIMPLATE, LOWER	white	1
912	175 123	TRIMPLATE, UPPER	blue	>
912	175 124	TRIMPLATE, UPPER	yellow	1
913	176 832	TITLE HOLDER SET III, black		1
	175 533	TRANSPORT DEVICES for TITLE HOLDER		1
	219 185	TITLE STRIP		120
	212 509	STICKER		--
914	175 926	GUIDE PLATE, REAR SIDE		1

SPARE PARTS LIST

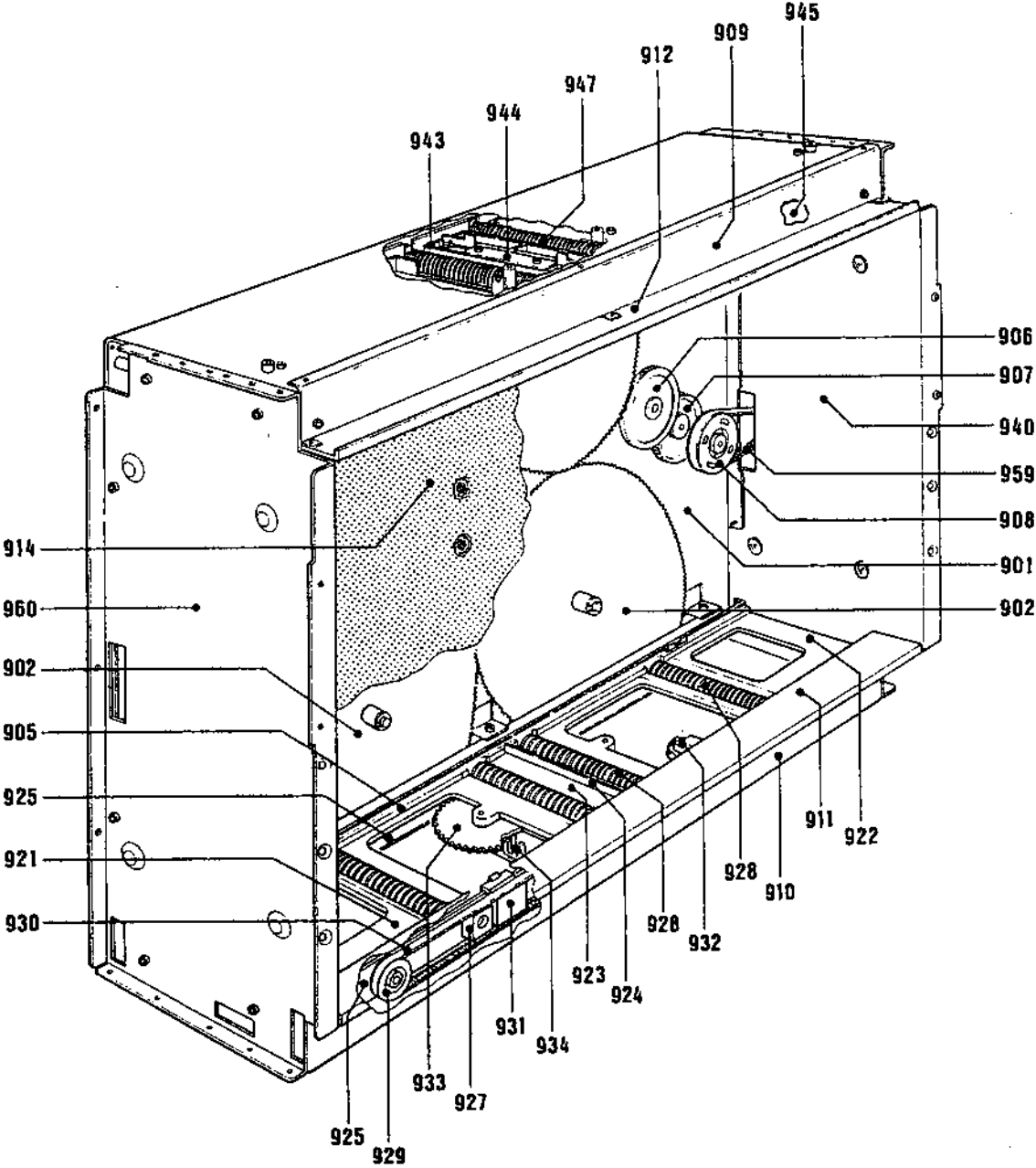

SPARE PARTS LIST

POS.	PART-No.	DESCRIPTION	DATA	QTY
<u>LOWER DECK</u>				
921	175 077	TRAVERSE I, ASSY		1
922	175 944	TRAVERSE II		1
923	175 322	TRAVERSE, MIDDLE		1
924	175 321	BRACKET		1
	741 008	BALL \varnothing 6 DIN 5401		2
	205 834	PRESSURE SPRING		2
925	174 906	HOLDING BAR, MOUNTED		1
946	176 563	HOLDING BAR, REAR SIDE (UPPER)		1
927	206 794	LOSS		2
928	174 751	WORM, ASSY, LOWER		4
	206 100	PLASTIC BEARING	STAR-NYLINER	4
929	174 898	BELT WHEEL	Z = 28	2
930	206 776	BELT	Typ S 2 M 800	2
931	174 846	DRIVE, FRONT SIDE		1
	175 952	DRIVE II, REAR SIDE		1
932	174 930	CB-DRIVER, ASSY	to TRAVERSE I/II	2
933	174 885	COUNTER WHEEL		1
934	175 078	CB-CB-COUNTER WHEEL, ASSY		1
	225 412	PIN PLUG	ST 1 4 prongs 90°	1
	231 322	COPPLER PLATE	SYNC LTH-301	1
	175 103	CABLE HARNESS: SHIFTING WHEEL		1
	175 104	CABLE HARNESS: DRIVE		1

SPARE PARTS LIST

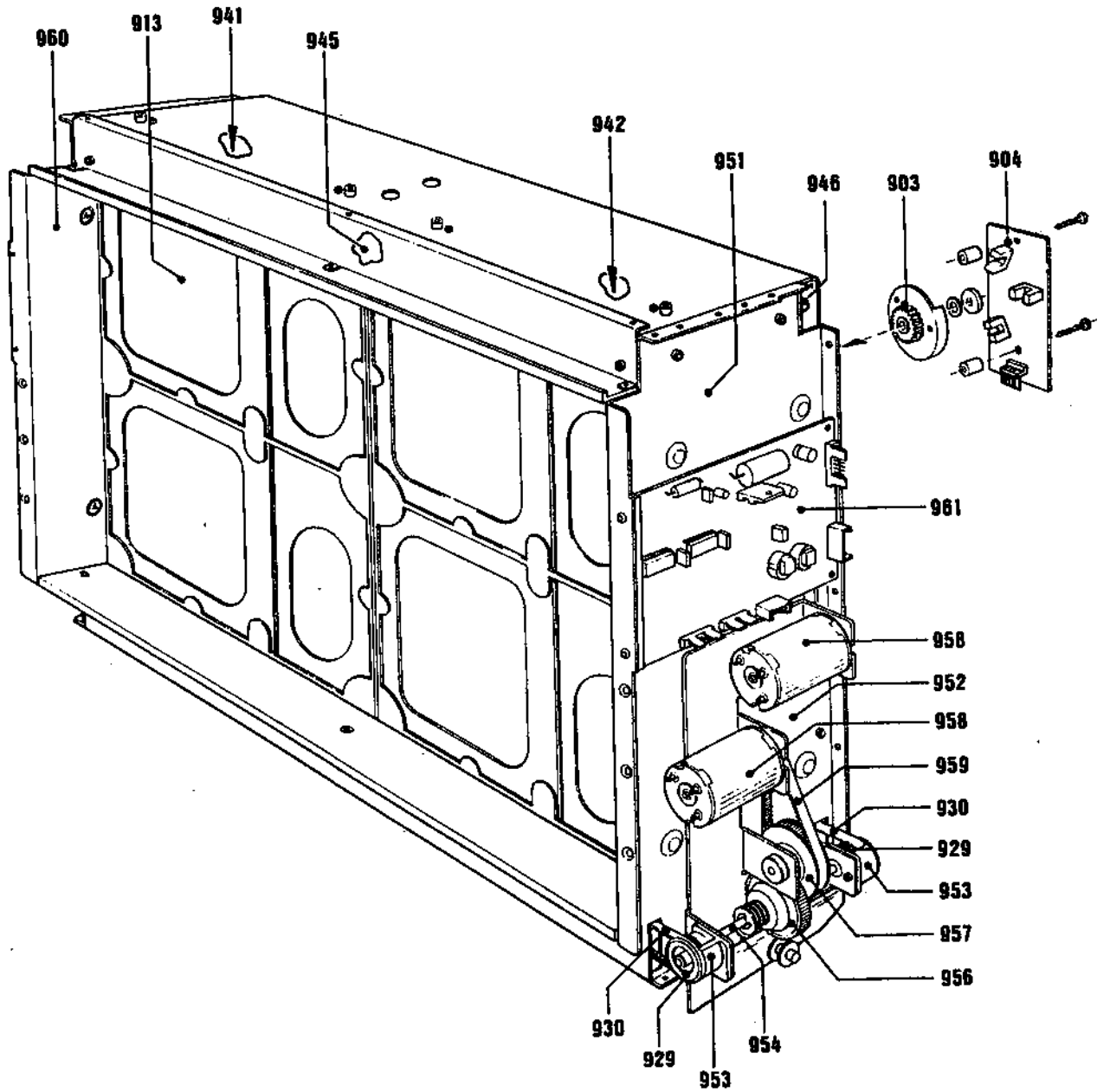

SPARE PARTS LIST

POS.	PART-No.	DESCRIPTION	DATA	QTY
<u>UPPER DECK</u>				
941	175 943	TRAVERSE I		1
942	175 944	TRAVERSE II		1
943	175 322	TRAVERSE, MIDDLE		1
944	175 321	BRACKET		1
	741 008	BALL \varnothing 6 DIN 5401		2
	205 834	PRESSURE SPRING		2
945	176 564	HOLDING BAR I (UPPER)		1
	206 100	PLASTIC BEARING	STAR-NYLINER	4
946	176 563	HOLDING BAR, REAR SIDE (UPPER)		1
947	174 764	WORM GEAR, ASSY, UPPER		4
<u>SIDE PARTS</u>				
951	174 932	SIDE PLATE, STAMPED, RIGHT		1
952	174 925	MOTOR- and GEAR PLATE, STAMPED		1
953	174 926	BELT PROTECTION, ASSY		2
957	174 878	BELT WHEEL	Z = 52	1
	174 879	WASHER		1
958	174 889	MOTOR, ASSY		2
	175 146	CABLE HARNESS-MOTOR		1
959	206 789	BELT	40 S 2 M 180	2
960	175 946	SIDE PLATE, LEFT		1
	206 880	SCOTCH BUMPON		8
961	174 928	CB-TITLE INDICATOR, ASSY	see page ...	1
	171 289	DISTANCE SLEEVE		1

SPARE PARTS LIST

POS.	PART-No.	DESCRIPTION	DATA	QTY
	174 928	CB-CD TITLE INDICATION II		1
ST 4	225 443	PIN PANEL	RM 2,5 6 prongs red	1
ST 3	225 444	PIN PLUG	RM 2,5 8 prongs red	1
ST 1	225 440	PIN PLUG	RM 2,5 10 prongs red	1
ST 2	225 710	PIN PANEL	4 prongs	1
ST 6	225 711	PIN PANEL	6 prongs	1
TL, TR	222 404	KEY	D 6 red	2
IC 1	221 763	IC-CMOS	HEF 4021 B	1
IC 2	221 771	IC-CMOS	HEF 4094 B	1
IC 3	231 303	IC-LINEAR	L 298	1
D 1-8	221 822	SI-DIODE	BA-157	8
D 9	221 114	SI-DIODE	1 N 4148	1
T 1	221 283	SI-TRANSISTOR	BC 212 B	1
C 1-3, 9	220 334	MKT-CAPACITOR	0,1 µF 63 V	4
C 6	220 332	MKT-CAPACITOR	0,33 µF 63 V	1
C 7	220 162	LYTIC	10 µF 63 V	1
C 4, 8	220 250	LYTIC	100 µF 25 V	2
C 5	220 253	LYTIC	1000 µF 25 V	1
R 33	221 620	RESISTOR	22 Ohm 1/4 W	1
R 31	221 600	RESISTOR	100 Ohm 1/4 W	1
R 25-27	221 033	RESISTOR	3,3 KOhm 1/4 W	3
R 19, 28-30	221 035	RESISTOR	10 KOhm 1/4 W	> 4
R 11-18	221 603	RESISTOR	12 KOhm 1/4 W	8
R 2-9	221 036	RESISTOR	15 KOhm 1/4 W	8
R 32	221 604	RESISTOR	22 KOhm 1/4 W	1
R 20	221 049	RESISTOR	470 KOhm 1/4 W	1
R 23, 35	221 273	RESISTOR	10 Ohm 1/2 W	2
R 21, 22	221 392	RESISTOR	390 Ohm 1/2 W	2
R 24	221 692	WIRE WOUND RESISTOR	1 Ohm	1
R 36	221 169	WIRE WOUND RESISTOR	10 Ohm	1

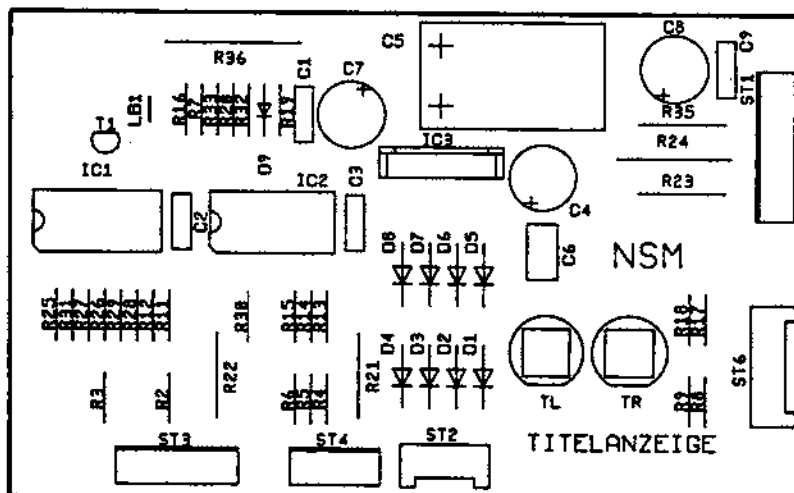

176 983 / 176 982 / 176 514 / 176 598
07/92

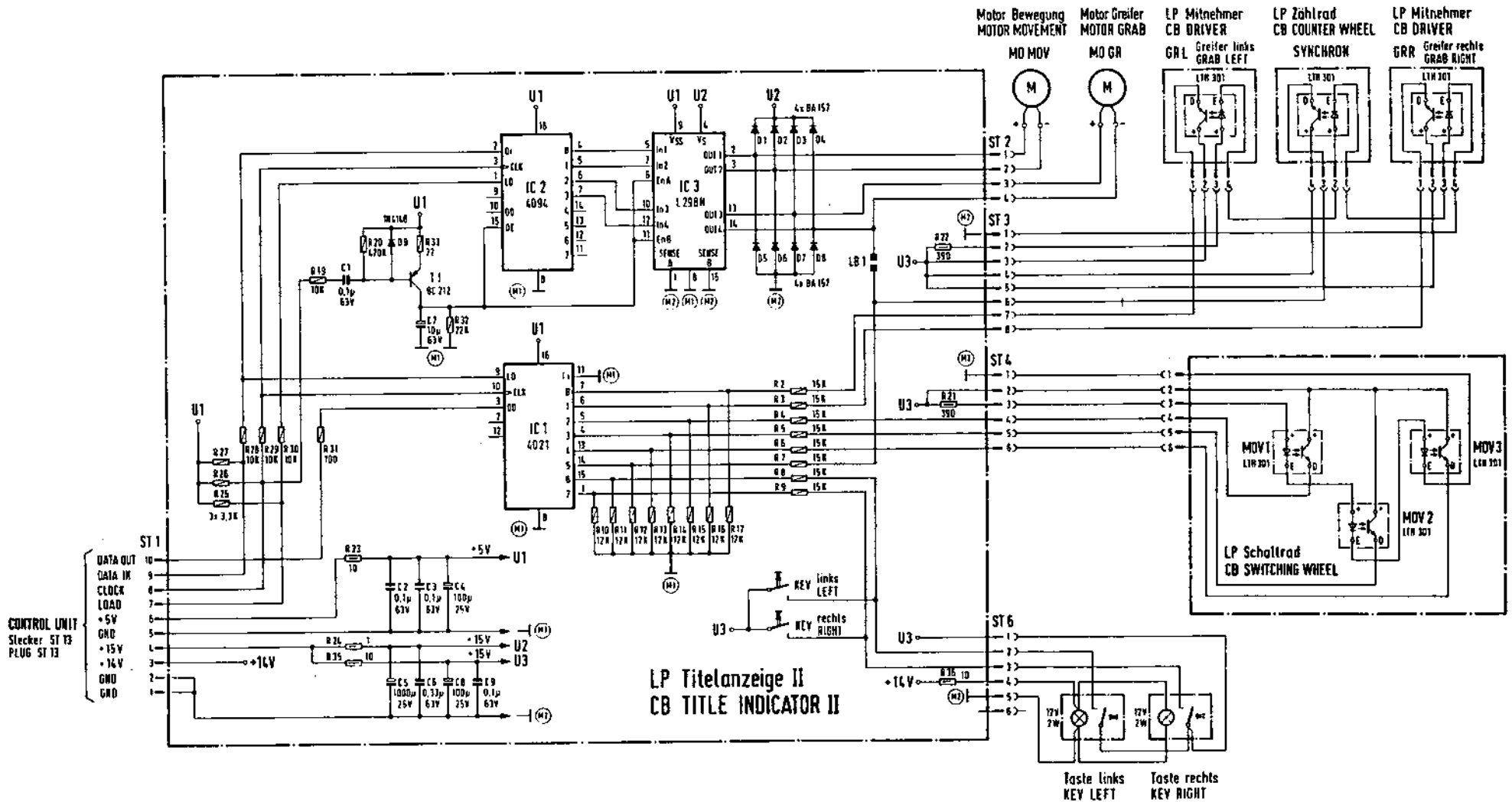

von unten gesehen
BOTTOM VIEW



Draufsicht
TOP VIEW

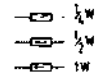
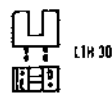

ÄNDERUNGEN IM SINNE DES TECHN. FORTSCHRITTES VORBEHALTEN,
JEDOCHEINE NACHRÜSTPFLICHT!
SUBJECT TO TECHNICAL MODIFICATION WITHOUT OBLIGATION
TO MODIFY EQUIPMENT ALREADY DELIVERED!

NSM MUSIKAUTOMATEN ES V-CD TECHNOLOGY
PHONOGRAPHIS

Schaltbild Titelanzeige II
WIRING DIAGRAM TITLE INDICATOR II

Rev	10.01.92	Ent	Braum	Gepr	...	Sign	...
-----	----------	-----	-------	------	-----	------	-----

UNIT DESCRIPTION

ELECTR. COIN- AND BILL ACCEPTOR FOR NSM-PHONOGRAPHS

ES V-CD TECHNOLOGY

to
Technical Information, Assy

176 393	THE PERFORMER GRAND II
176 352	THE WIZARD / OLD FASHION WIZARD
176 514	THE PERFORMER CLASSIC
176 598	FIREBIRD II

NSM

Aktiengesellschaft
Saarlandstraße 240
6530 Bingen am Rhein

10

Page 1001-1506

INDEX

- 1 MECHANICAL COIN CHUTE**
- 2 BILL VALIDATION - DOLLAR BILL ACCEPTOR**
- 3 MARS ELECTRONIC COIN VALIDATOR**
 - 3.1 Monetary Value Settings**
 - 3.2 Price Tables**
 - 3.3 Other Settings/Information**

1 MECHANICAL COIN CHUTE

See also the circuit in the wiring diagram in the appendix of the "Technical Information".

The coins that come out of the "good" channels of the coin acceptor run through different optic barriers. The optic barriers are in the coin chute under the coin acceptor.

Two photo transistors, T III and T I as well as T IV and T II are illuminated by one IR diode each (LED I and LED II).

As long as a light barrier is not interrupted by a coin, all photo transistors, T I to T IV, are switched to logically "0". So all output lines.

1 = T IV,

2 = T III,

3 = T I,

4 = T II are at logically "0", i.e. their voltage level is 1,0 V.

If a coin passes through an optic beam, the respective photo transistor is darkened for that time. The output becomes log. "1" via the pull-up resistors in the control unit, i.e. their level is 10 V.

Since T I is also darkened, when T III is effected by a coin (T I is behind T III, both are illuminated by the same light diode), the output from T I over T V is kept at "0". This occurs via resistors R 72, R 70; they bring transistor T V in a satiated state when T III is open.

The same goes for T IV; it is kept at "0" by T VI when a coin falls through T II. The control for T VI occurs via R 73, R 69.

The addition button is switched in sequence to T IV so that Line 1 becomes log. "1" at service credit.

R 67 limits the current of the luminous diodes LED I and LED II.

The output signals of the four photo transistors are evaluated in the control unit whereby line.

1 = P 74,

2 = P 73,

3 = P 72,

4 = P 71 is assigned to the monetary value setting in the service program and is to be programmed according to the coin value; see "Statistics and Service Programs", Section 1.4.

2 BILL VALIDATION - DOLLAR BILL ACCEPTOR

See also the circuit in the wiring diagram in the appendix of the "Technical Information".

The bill validator, after the bill has passed through and been accepted, sends as many pulses to the control unit as correspond to the value of the bill.

The output of the bill validator is connected to the control unit via ST 9, Pins 1 and 2. 1 pulse is sent to the control unit with 1 dollar and 5 pulses with 5 dollars.

The input of the bill validator is assigned to program step P75 and is to be programmed accordingly; see "Programs", Section 1.4.

3 MARS ELECTRONIC COIN VALIDATOR

4 or 5 different coins be checked depending on the type. The three sensors in the validator register each separately the width, material composition and pressure of each deposited coin. If a deposited coin passes the sensors, the prepared data are passed on to a register and compared with the contents of a memory (PROM). If validation criteria are identical with a data set of the PROM, an internal "valid" signal is produced. Depending on the coin value it goes as output signal A1 to A5 to the plug of the PCB adapter (depending on type of validator, 15 or 13 poled). From there the signal goes via the 6-pole plug to control unit CD for processing.

3.1 Monetary Value Settings

The information in the "Operating Instructions" and the statistics and service program about monetary value settings refer to coin mechanisms with mechanical coin acceptors.

If a electronic validator has been installed, the monetary value settings in the individual program steps are assigned to corresponding output signals: P71 to signal A1 or A5, P72 to A3, P73 to A4, P74 to A2.

Notice: When inserting a coin during program steps 70-75, the program step (channel P71 to P75) assigned to the coin is automatically displayed in Display 1.

The monetary values are programmed in monetary value units: "001" $\hat{=}$ 0,10 DM, "010" $\hat{=}$ 1,- DM, "020" $\hat{=}$ 2,- DM, "050" $\hat{=}$ 5,- DM. No-used channels are programmed with "000".

3.2 Price Tables

Set the number of credit per monetary value in program steps P61 to P65 as described in the "Statistics" and Service Program, 1.3.2 Price Tables".

3.3 Other Settings/Information

When exchanging the control unit the programming has to be done in the new unit also.

Attention! When checking the monetary value settings in P74, the cabinet switch has to be pushed in; otherwise only one credit will be displayed instead of set coin value.

Notice: Non-used channels can be blocked. For this purpose the bridge of the corresponding channel (A1-A5 on the PCB) has to be disconnected or conductor A5 is not connected.

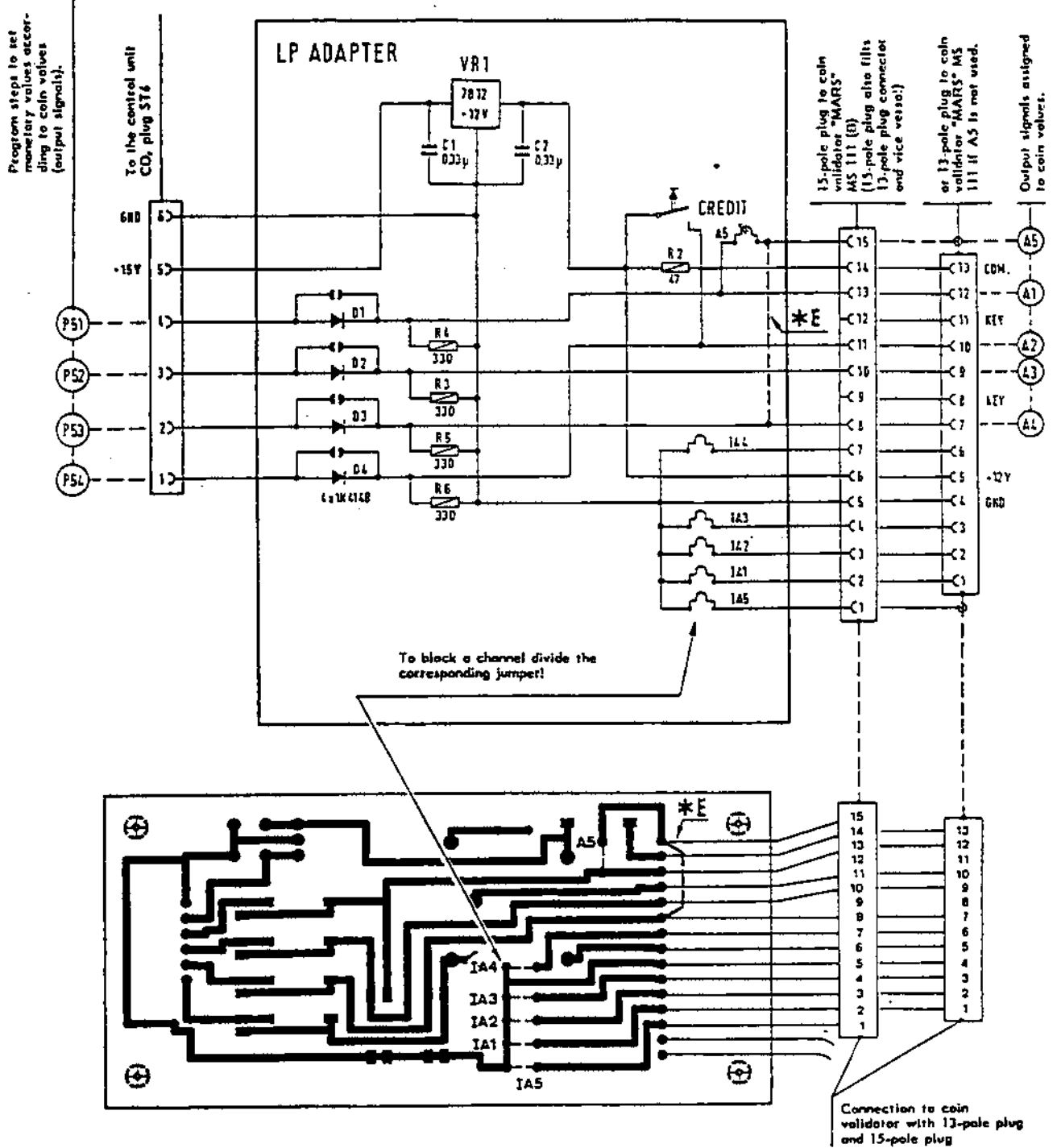

MONETARY VALUE SETTINGS SEE BACK PAGE

Programming Table for Mars-Coin acceptor

Monetary Value Settings

Programming of monetary values and values settings according to the (individual) coin legend (1)

Currency	Monetary Values Δ Coin Value P71 (A1/A5)	P72 (A3)	P73 (A4)	P74 (A2)	Discon. Jumpers	Coin Validator - Type
Germany	050 Δ 5.- DM	010 Δ 1.- DM	000 Δ 00	020 Δ 2.- DM	IA4/IA5	GDE58 L00K/B1/GDE55L00C/B1
Great Britain	100 Δ 1 £ 100 Δ 1 £	020 Δ 20p 020 Δ 20p	010 Δ 10p 010 Δ 10p (new) 10p (old)	050 Δ 50p 050 Δ 50p	IA5 A 5	GDB 31 L00C/GGB81 L000C/ B1 GGBG3 L00C/02 * E
USA	100 Δ 1 \$	025 Δ 25 c	000 Δ 00	050 Δ 50 c	IA4	GUS 20 L00C
Australia	000 Δ 00	100 Δ 1 \$	020 Δ 20c	200 Δ 2 \$		GAS XX L00C B1/ GAS 1A L00C
	200 Δ 2 \$	000 Δ (50c)	020 Δ 20c	100 Δ 1 \$	IA3	GAS 28 L00C
France	100 Δ 10 F	020 Δ 2 F	010 Δ 1 F	050 Δ 5 F		GFR 19 L00C
	100 Δ 10 F (old) 10 F (new)	020 Δ 2 F	010 Δ 1 F	050 Δ 5 F		GFR 96 L00C / B1 * F
	100 Δ 10 F (new)	020 Δ 2 F	010 Δ 1 F	050 Δ 5 F		GFR B7 L00C 02
Denmark	000 Δ 00	050 Δ 5 dkr	010 Δ 1 dkr	100 Δ 10 dkr		by 3-Canal GDK xx L00C
	100 Δ 10 dkr	010 Δ 1 dkr	000 Δ 0,25 dkr	050 Δ 5 dkr	IA4	by 4-Canal GDK 02 L00C
	100 Δ 10 dkr (new)	050 Δ 5 dkr	010 Δ 1 dkr	100 Δ 10 dkr (old)		by 4-Canal GDK 1A L00C
	200 Δ 20 dkr	050 Δ 5 dkr	010 Δ 1 dkr	100 Δ 10 dkr		GDK 1D L00C / GDK 1N L00C
Finland	000 Δ 00	050 Δ 5 MK	010 Δ 1 MK	000 Δ 00		GSF 1A L00C
Austria	200 Δ 20 S	050 Δ 5 S	010 Δ 1 S	100 Δ 10 S	A5/IA5	GAU 03 L00C
Neth. Antillen	000	000	100 Δ 1 NAF	000	A5/IA5	GNA 1A L00G / B1 GNA 1A L00C / 02
Switzerland	050 Δ 5 Fr	010 Δ 1 Fr	000 Δ 1/2 Fr	020 Δ 2 Fr	IA4/IA5	GCH 31 L00C / B1
Belgium	050 Δ 50 Fr	000 Δ 5 F (new)	000 Δ 1 F	020 Δ 20 F	IA3/IA4 (A3/A4)	GBE 19 L00C / B1
	050 Δ 50 F 1 F (new)	005 Δ 5 F (new)	000 Δ 1 F (old)	020 Δ 20 F	IA4/IA5	GBE 25 L00C / B1 GBE 19 L00C / B1
Netherland	025 Δ 25 c	250 Δ 2 1/2 hfl	500 Δ 5 hfl	100 Δ 1 hfl		GNL 37 L00C / B1
Italy	050 Δ 500 L	000 (100 L)	000 (50 L)	020 Δ 200 L	IA3/IA4	GIT 06 L00C
	050 Δ 500 L	010 Δ 100 L	000 (50 L)	020 Δ 200 L	IA4/IA5	GIT 26 L00C / B1
USA	010 Δ (10c)	050 Δ (50c)	025 Δ 25c	100 Δ (1 \$)	IA5	GUS 1B L00C / B1
New Zealand	050 Δ 50 c	010 Δ 10 c 1 SHILLING	005 Δ 5 c	020 Δ 20		GNZ 03 L00C
	200 Δ 2 \$	050 Δ 50 c	020 Δ 20 c	100 Δ 1 \$	IA4/IA5/A5	GAS 41 L00C / 02 AS / NZ
Canada	010 Δ 10 c	100 Δ 1 \$	025 Δ 25 c	000		GCN 1A L00C
Spain	200 Δ 200 Pst	050 Δ 50 Pst	025 Δ 25 Pst	100 Δ 100 Pst		GES 1J L00C
Norway	100 Δ 10 Kr	010 Δ 1 Kr	(000 Δ 1/2 Kr)	050 Δ 5 Kr	IA4	GN 008 L00C
Sweden	050 Δ 5 Kr	010 Δ 1 Kr	000 Δ (50 örn)	010 Δ 1 Kr	IA4	GSW 09 L00C
Greece	(010) MP closed	050 Δ 50 Dr	020 Δ 20 Dr	000		GGR 1C L00C
Korea	000	010 Δ 10 NTS	005 Δ 5 NTS	000		GTW 1A L00C
Mexico	000	000	010 Δ 1000 P	000		GME 1A L00C
Hong Kong	050 Δ 5 \$	010 Δ 1 \$	000	020 Δ 2 \$		GHK 1A L00C / B1
Hungaria	020 Δ 20 F	005 Δ 5 F	000	010 Δ 10 F	IA4/IA5	GHU 1B L000C / B1
Thailand	000	000	005 Δ 5 Baht	000		GTH 1A L00C / 02
South Africa	020 Δ 2 R (new)	010 Δ 1 R (old)	005 Δ 5 C (old) (new)	010 Δ 1 R (new)	A5	GZA 1B L00C / B1 * E

* F A5 and IA 5 closed

* E additional jumper from
pin 15 to 8
(A5) (A4)

UNIT DESCRIPTION REMOTE CONTROL FOR NSM-PHONOGRAPHS

ES V-CD TECHNOLOGY

to
Technical Information, Assy

176 393	THE PERFORMER GRAND II
176 352	THE WIZARD / OLD FASHION WIZARD
176 514	THE PERFORMER CLASSIC
176 610	CD HIDE-AWAY II
176 598	FIREBIRD II

NSM
Aktiengesellschaft
Saarlandstraße 240
6530 Bingen am Rhein

11

Page 1101-1105

INDEX

- 1** **FUNCTION**
- 1.1** **Infra-red remote control (wireless)**
- 1.2** **Wired remote control**
- 1.3** **Installation instructions for infra-red remote control**
- 1.4** **Volume control (on rear cabinet wall)**

INFRARED REMOTE CONTROL, ASSY.

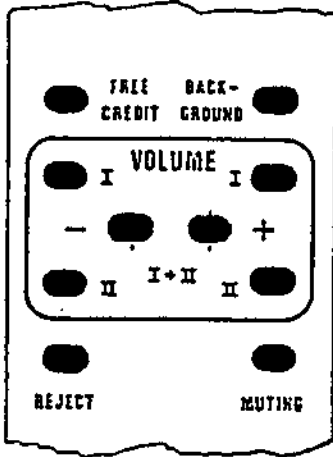

with 1,5 m Cable
with 5,0 m Cable

171 808
174 258

sender

206 783

Receiver with Cover

173 178

REMOTE CONTROL with 5 m cable

Part No.

171 743

VOLUME CONTROL

Part-No. 170 212

Option: This volume control is a remote alternative to the control installed in the device. (For connections see par. 1.4) The cable has to be extended - any 4 pole cable can be used.

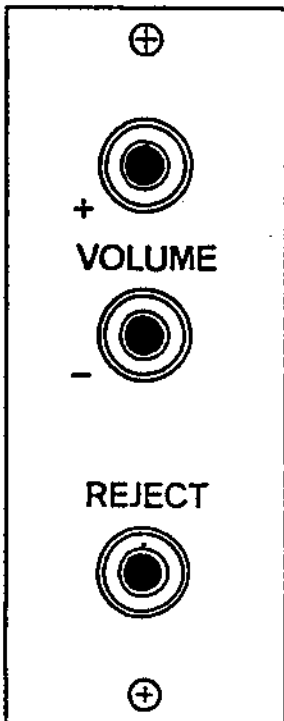

to 1.4

1 FUNCTION

1.1 Infrared remote control (wireless)

The cable of the remote control receiver has to be put into plug ST 205 of the central unit.

Pin 1 supplies the +15 V voltage.

Pin 2 = GND

The commands - as per chart - are fed to the computer inputs via Pins 3 through 6 by switching to ground.

The signals go to the control unit via plug ST 201.

1.2 Wired remote control

For remote controls with cable the plug has to be connected with ST 205 on the central unit (instead of infrared remote control). The corresponding channels (Pins 3 through 6) - as per chart - are connected to GND Pin 2 via the remote control diode linkage.

TASTE / KEY	AUSGANGS-CODE OUTPUT-CODE	STECKER / PLUG ST 205 / PIN
VOLUME - 1	2 / 4	5 / 3
VOLUME + 1	4	3
VOLUME - II	2 / 3	5 / 4
VOLUME + II	3	4
FREE CREDIT	1 / 3	6 / 4
BACKGROUND	1 / 4	6 / 3
REJECT	2	5
MUTING	1	6
VOLUME + (I+II)	3 / 4	4 / 3
VOLUME - (I+II)	2 / 3 / 4	5 / 4 / 3

1.3 Installation Instructions for Infrared Remote Control

The receiver with standard connection cable is mounted onto the back of the cabinet or the back of the hood when a small distance is involved. The top (receiving side) of the receiver should be mounted a little underneath the upper edge of the rear cabinet. Wallboxes and Hide-Away's have to be mounted close to the machine.

If a greater distance has to be bridged or an absorbing ceiling is influencing correct functioning the receiver has to be mounted in such a way on the wall or the ceiling that direct radiating of the manual sender is possible. A connection cable (5 m), Part. No. 170 459, is available for this purpose. The connection cable of the receiver is put into plug S 205 of the central unit.

SECURING MANUAL SENDER

To protect the manual sender from theft, mount the bracket with two screws onto the back of the sender (see fig.). This way the sender can be secured with a chain.

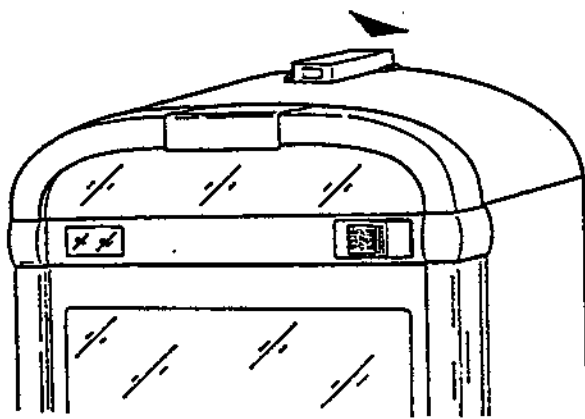

Fig. 1

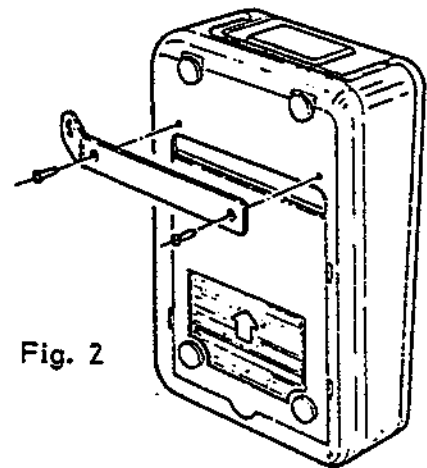

Fig. 2

Manual sender with safety bracket and screws

1.4 Volume Control (On Rear Cabinet Wall does not apply to wallboxes and Hide-Away's).

The connection cable must be put into plug ST 206 of the central unit. When the volume keys are pressed, the computer inputs are switched to GND via the diode linkage D 213-217.

TASTE / KEY	AUSGANGS-CODE OUTPUT-CODE	STECKER / PLUG ST 201 / PIN
VOLUME + (I+II)	3 / 4	6 / 7
VOLUME -(I+II)	2 / 3 / 4	5 / 6 / 7
REJECT	2	5

UNIT DESCRIPTION

OUTPUT TRANSFORMER

FOR NSM-PHONOGRAPHS

ES V-CD TECHNOLOGY

to
Technical Information, Assy

176 393	THE PERFORMER GRAND II
176 352	THE WIZARD /
	OLD FASHION WIZARD
176 514	THE PERFORMER CLASSIC
176 610	CD HIDE-AWAY II
176 598	FIREBIRD II

NSM
Aktiengesellschaft
Saarlandstraße 240
6530 Bingen am Rhein

13

Page 1301-1304

OUTPUT TRANSFORMER with cable harness

Part.-No. 172 431

The output transformer is connected directly to the terminals of the output amplifier. It has input impedance of 4 ohms and transforms the input voltage down so that smaller output voltages are available at Connection Terminals 1 through 5 permitting speakers with lower impedances to be connected.

A number of loudspeakers can be connected together (in parallel) up to a total maximum power of 130 W music power per channel; depending on how much power is taken directly from the amplifier. The table below shows the power required for a loudspeaker with the corresponding impedance at Connection Terminals 0-1 through 0-5. Also observe the output transformer diagram and connection schematics. Further information is given in the "TECHNICAL INSTRUCTIONS" under "Loudspeaker Connection".

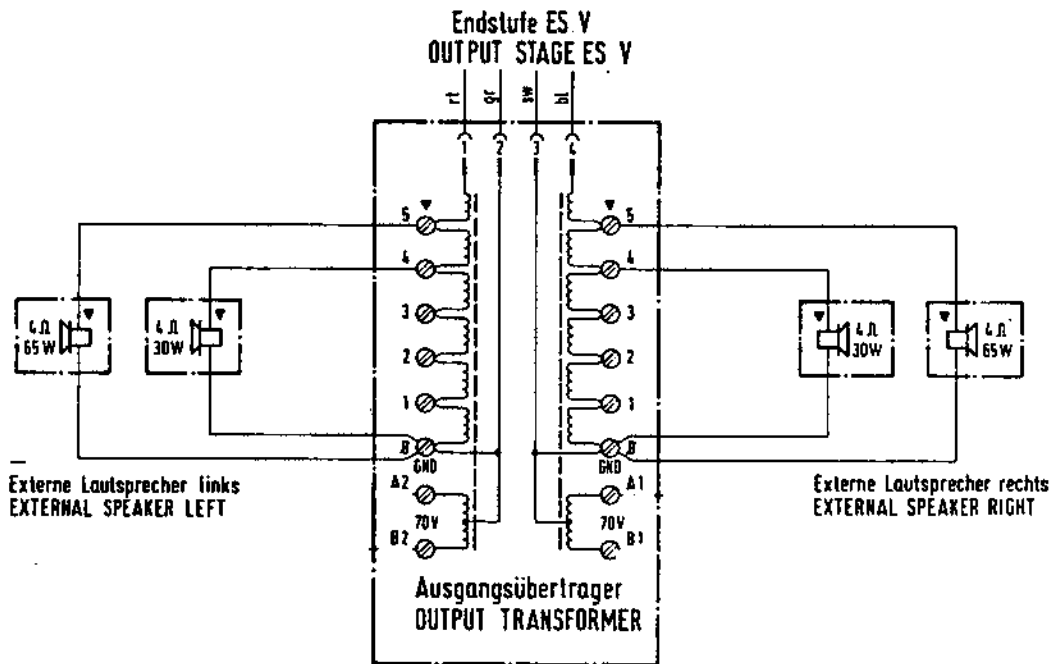

Anschlußschema für Ausgangsübertrager
CONNECTION DIAGRAM FOR OUTPUT TRANSFORMER

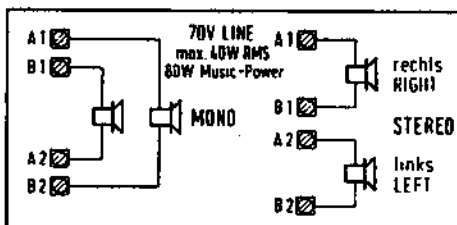

Klemme TERMINAL POSITION	Lautsprecher SPEAKER				
	2 Ω	2,5 Ω	4 Ω	8 Ω	16 Ω
0 - 5	130 W	100 W	65 W	35 W	18 W
0 - 4	60 W	48 W	30 W	16 W	8 W
0 - 3	30 W	24 W	15 W	8 W	4 W
0 - 2	15 W	12 W	7,5 W	4 W	2 W
0 - 1	3,7 W	3 W	1,8 W	1 W	0,5 W

Maximum Power Output Connections

The maximum power output of the amplifier is 2x200 W music power at 2 ohms.

The following is an example of how to connect external loudspeakers to the "CD GALAXY": The phonograph itself consumes (when directly connected at 5,5 ohm impedance) 2x70 watts.

Therefore, 2x130 W is still available for external loudspeakers.

For example, two 4-ohm loudspeakers each can be connected to Terminals 0-5 (see diagram) or four loudspeakers (with 4 ohms each) can be connected to Terminals 0-4.

Example for connection of wallboxes or Hide-Away's

If loudspeakers with 4 ohm are connected directly to a wallbox or Hide-Away, the consumption is 100 watts; therefore there is only 100 watts left for the loudspeaker connected to the transformer.

Connection for Lower Phonograph Output Power

When full power is not required from the phonograph, it can be connected to the corresponding terminals of the transformer and external loudspeakers can then be connected directly to the output amplifier for higher output.

70 V - High Voltage Output

Additionally, the transformer also has a 70 V high-voltage output (A1-B1/A2-B2) for each channel.

These features are provided for operation of a widespread external loudspeaker system whereby the higher voltage keep the line losses low. Only loudspeakers with input transformers (socalled high-impedance loudspeakers of 50 ohms upwards) can be connected to this terminal. these outputs also provide a maximum of 80 W music power each, e.g. two 50 W loudspeakers (200 ohms) can be connected to each channel.

Lautsprecher-impedanz Loudspeaker-Impedance	Music-Ausgangsleistung Output power (music)	A1-B1
		A2-B2
		Sinus-Ausgangsleistung RMS Output power
50 Ohm	80 W	40 W
100 Ohm	50 W	25 W
150 Ohm	35 W	18 W
200 Ohm	28 W	14 W
250 Ohm	20 W	10 W

The total wattage of all remote loudspeakers connected to one channel of the output transformer (whether low impedance, high impedance or combined) may not exceed max. 130 W.

HV - MONO Mode

Since the high-voltage coils are connected with their center, a loudspeaker connected to A1-B2 or B1-A2 radiates sound from both (stereo) channels; for this mono mode no special NF-coupling of the channels is necessary, coupling is provided by the transformer.

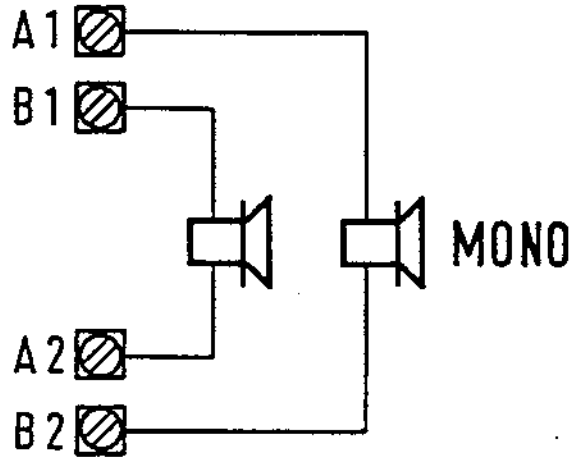

HV - STEREO Mode

If the loudspeakers are connected to A1-B1 or A2-B2, stereo mode is possible, but without NF-coupling of the channels.

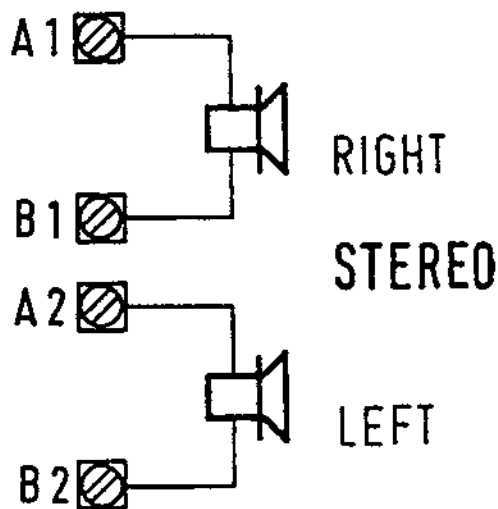

TROUBLE SHOOTING FOR NSM-PHONOGRAPHS

ES V-CD TECHNOLOGY

to
Technical Information, Assy

176 393	THE PERFORMER GRAND II
176 352	THE WIZARD / OLD FASHION WIZARD
176 514	THE PERFORMER CLASSIC
176 610	CD HIDE-AWAY II
176 598	FIREBIRD II

NSM

Aktiengesellschaft
Saarlandstraße 240
6530 Bingen am Rhein

14

Page 1401-1406

INDEX

- 1 DESCRIPTION OF MALFUNCTION / CAUSE**
- 2 ERROR DISPLAYS / TABLE OF ERROR MESSAGES**
- 3 TROUBLE SHOOTING FOR NSM PHONOGRAPHS ES-IV/CD TECHNOLOGY**

1 DESCRIPTION OF MALFUNCTION / CAUSE

The following table gives a short reference of the possible solution to repair a phonograph that did not work.

DESCRIPTION	CAUSE
Phonograph illumination and LED's in central unit/CD supply do not light up.	<ol style="list-style-type: none"> 1. Power cord 2. Main switch 3. Power fuse (switch plate/fuse box)
Phonograph illumination okay, LED's in central unit do not light up.	<ol style="list-style-type: none"> 1. Plug connection ST 1 of central unit 2. Fuses Si 1-5 of central unit 3. Power transformer connection
Fan for output stage does not run while disc is playing.	<ol style="list-style-type: none"> 1. Plug connection ST 4 2. Triac TI 1 3. Transistor T 2 / T 1
LED's in central unit do not light up or are darker Fuses are okay.	<ol style="list-style-type: none"> 1. Voltage regulators VR 1-6 in central unit defective 2. Short circuit in connected units. (Pull plugs one after another and observe LED's).
No tone signal at loudspeaker even though a CD is playing and the switched on.	<ol style="list-style-type: none"> 1. loudspeaker connection 2. Plug connection of frequency volume is network and output transformer 3. Interruption on signal wire
Volume reduced by electronic protection device.	<ol style="list-style-type: none"> 1. loudspeaker mismatch (less than 2 ohms impedance) due to remote speakers. 2. Transistor T 9 defective. 3. Output transistor defective. 4. Control unit defective.
Poor bass reproduction.	<ol style="list-style-type: none"> 1. Loudspeaker connections reversed.
Er xx-display.	See "Error Displays".
Luminous effect lights do not light phonographs with light generator).	<ol style="list-style-type: none"> 1. Fuse on PCB light organ (running light) 2. Plug connection to PCB light organ

2. ERROR DISPLAYS / TABLE OF ERROR MESSAGES

After power on the phonograph, respectively after each closing of the programming mode the microprocessor on the PCB Control Unit checks all memoried values. If there is detected an error on the programmable memory area, the corresponding programm step is entered. The display shows the command number Pxx and "Er 31" is flashing. Also the lamp "error" flashes.

With input of the correct value and pressing the key "H" this error is cleared.

After power on the phonograph, the malfunction display "Display 3" an the flashing lamp "error" remains visible for 2 sec. Here after the phonograph is operational without regarding the malfunctioning part.

When entering the programming mode there is a possibility for service and maintenance requests. With the command of group 15x and 16x it is possible to check, or to initialise CD's to, the phonograph. By using P150 the last 20 errors are display sequentially including the information about CD-no. and date of occurance.

The following table gives an overview of the error messages and the possible corrections.

Table 4: "Error Displays"

Displays			Possible Causes	Corrections
1	2	3		
Er	01		EPROM contents (CONTROL UNIT) disturbed.	Change EPROM (IC 2).
Er	10		RAM (CONTROL UNIT) defective.	Change RAM (IC 3). After that reprogram all program steps.
Er	11		RAM contents (CONTROL UNIT) short-term disturbance.	No correction necessary; program is reinitialized. Change RAM IC 3 if frequently occurring.
Er	12		RAM battery is empty.	Change RAM (IC 3). After that reprogram all program steps.
Er	20		Verification errors in program (CONTROL UNIT).	No correction necessary; program is reinitialized. Change CPU IC 1 if frequently occurring.
Pxxx	Er	30	Memory contents (CONTROL UNIT) invalid.	No correction necessary; program step Pxxx (in Display 1) is automatically reprogrammed.
Pxxx	Er	31	Memory contents (CONTROL UNIT) invalid or not programmed.	Program step Pxxx shown in Display 1 must be reprogrammed.
Pxxx	Er	40	Wrong price setting.	Check price setting and, if necessary, reprogram (P060).
Er	50		Coin mechanism defective. Too much credit.	Check coin mechanism.
Er	6x		Error at CD player.	See Er 80 - Er 83.
Er	60		Connection to the CD-player interrupted. No supply voltage present for decoder board or CD player.	Check connection cables to the decoder board, check fuses.
Er	61		No CD recognized by CD player. No CD in CD tray. CD defective. Player defective.	Check CD and exchange if needed. Exchange CD player. Exchange decoder board.
Er	62		Specified track on the CD not found.	Check the CD.
Er	63		Malfunction while playing a CD.	Check the CD player with equipped CD for easy running.
Er	7x		Malfunction on CD changer.	If error display does not disappear after 2 sec., error cannot be automatically corrected. No CD will be played until cabinet switch or "power on" is activated.
Er	70		Malfunction of operating control.	No correction necessary.
Er	71		Error during grip from magazine.	Equip CD-tray to magazine. Check alignment from magazine to pickup assy and adjust if necessary. Check function of light barrier OPPUM.
Er	72		Error during replacing CD in magazine. Malfunction of grip lever.	Check alignment of magazine to pickup assy and adjust if needed. Check function of grip. Check function of light barriers OPGR1 and OPGR2.
Er	73		Malfunction during lift drive. Playing of CD not possible.	Check lift for jamming. Check function and correct adjustment of light barrier OPSTP (drive wheel).
Er	74		End position of lift not o.k.. Playing of CD not possible.	Check function and adjustment of light barrier OPEND.
Er	80		Short circuit on wallbox signal wire.	Check wallbox connection.
Er	81		Malfunction of the sound chip.	Change PCB "CENTRALE-CD" if frequently occurring.
Er	90		Title display, three blocking in sequence, not functional anymore.	} Blocking remedy.
Er	91		Blocking title display.	
Er	92		Blocking title display.	
Er	93		Blocking title display, stack left.	
Er	94		Blocking title display, stack right.	

3 Trouble-Shooting Chart for NSM Phonographs ES-V/CD Technology

Conditions: Line voltage present, line connection and power supply in order.

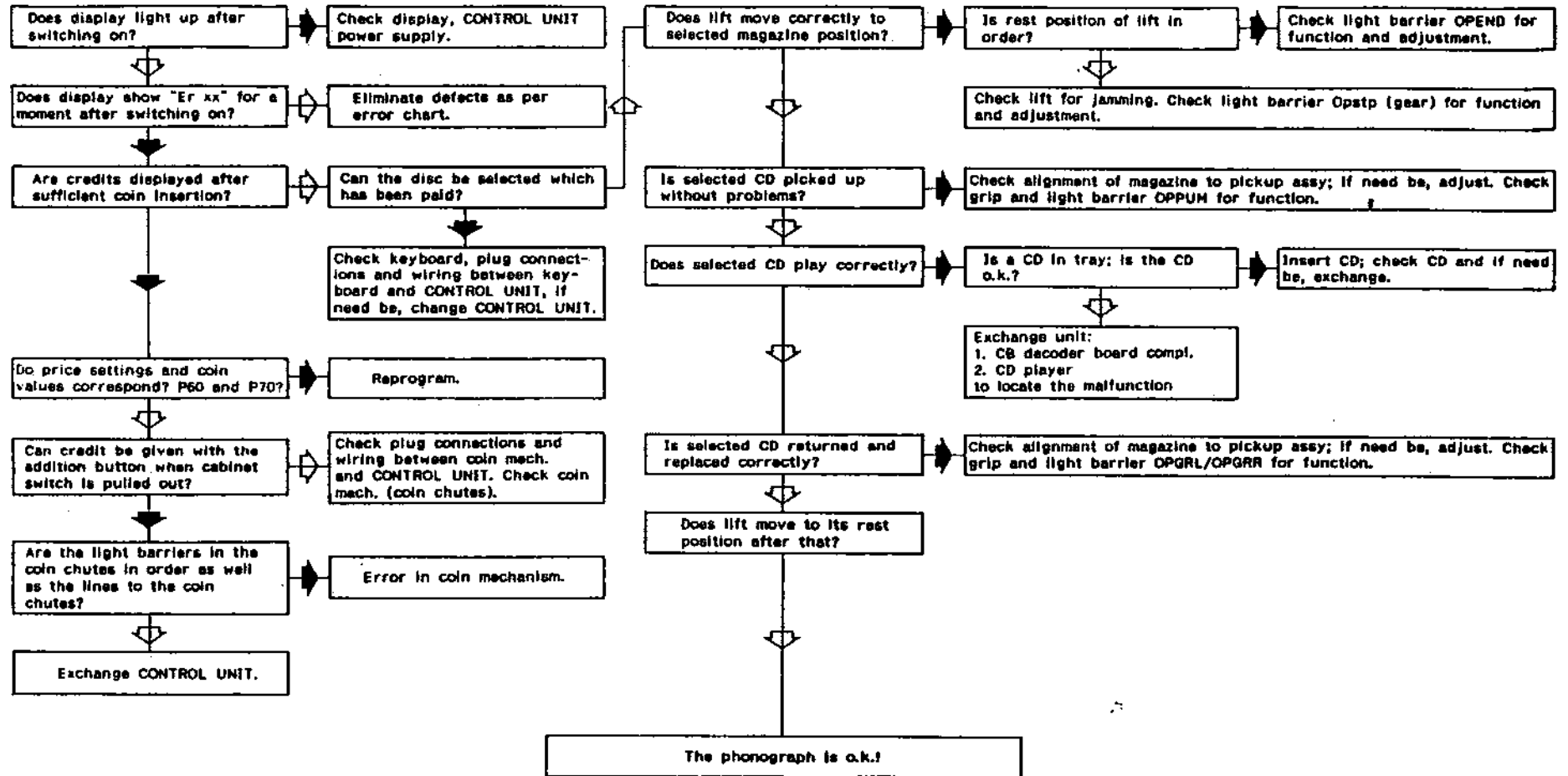

◁ : ja
 ▷ : nein
 Compare also 1.2 "Error Displays".

ACCESSORIES

FOR NSM-PHONOGRAPHS

ES V-CD TECHNOLOGY

to
Technical Information, Assy

176 393	THE PERFORMER GRAND II
176 352	THE WIZARD / OLD FASHION WIZARD
176 514	THE PERFORMER CLASSIC
176 610	CD HIDE-AWAY II
176 598	FIRBIRD II

NSM

Aktiengesellschaft
Saarlandstraße 240
6530 Bingen am Rhein

15

Page 1501-1504

INDEX

- 1 MICROPHONE with paging switch
- 2 REMOTE CONTROL WALL BOXES
- 3 REMOTE CONTROLS
 - 3.1 Infrared remote control
 - 3.2 Remote control with cable
- 5 OUTPUT TRANSFORMER with cable
- 6 CASH COUNTER
- 7 DATAPRINT
 - 7.1 Data transfer and memorizing
 - 7.2 Transfer to Printer

1 MICROPHONE with Paging Switch

REQD

Connection via microphone socket to the central unit. Microphone announcements are possible in any phonograph mode.

The microphone amplifier with electronic switch-over is integrated into the central unit. The volume for the background music and microphone can be adjusted separately in the central unit.

Connection cable with plug and microphone socket-length 10 m or 25 m (Part-No. see Spare Parts List in "Technical Instructions").

2 REMOTE CONTROL WALL BOXES

FIRE STORM w. Title indication II
CARAVELLE II w. Title indication II

For connection to NSM phonographs in CD technology. Connection Adapter belongs to the equipment. (Part-No. see Spare Parts List in "Technical Instructions"). Detailed installation instructions are included in the adapter kit.

3 REMOTE CONTROLS

3.1 Infrared Remote Control

Wireless remote control consisting of transmitter, receiver and parts for installations. See wiring diagram for connections. (Part-No. see Spare Parts List in "Technical Instructions").

3.2 Remote Control with Cable

The connection points are illustrated in the wiring diagram and described in unit description "REMOTE CONTROL". (Part-No. see Spare Parts List in "Technical Instructions").

5 OUTPUT TRANSFORMER with cable

Significantly expanded adaptation capabilities and low line losses with 70 V output. (See Unit description "OUTPUT TRANSFORMER"). (Part-No. see Spare Parts List in "Technical Instructions").

6 CASH COUNTER

NSM phonographs can be subsequently modified with an electro-mechanical cash counter (12 V = pulse counter). (Part-No. see Spare Part List in "Technical Instructions").

7 DATAPRINT

The printer is intended for connection to NSM phonographs ES IV-CD Technology. A detailed description is included with the printer. Putting in the paper roll and color ribbon are described in detail in the "TECHNICAL INSTRUCTIONS" for the DATAPRINT.

7.1 Data Transfer and Memorizing

- Turn on service program by opening cabinet and pull out cabinet switch manually, Display 1 "P010".
- Put in printer connector into "Service Socket" of the Control Unit.
- Enter "C", Display 1 "P".
- Enter "30" and "H", Display "P030".
- Enter Code "0" and "H".

Counters + Errors, as well as popularity are transferred.

Note: Display 3 "E0" appears if an error occurs during data transfer.

7.2 Transfer to Printer

- Switch on service program by opening cabinet; if needed, pull the cabinet switch manually, Display 1 "P010".
- Plug printer connector into socket of Control Unit.
- Enter "C", Display 1 "P".
- Enter "31" and "H", Display 1 "P031".
- Enter code for the desired print-out and press "H".
 - "0" and "H" = complete information
 - "1" and "H" = all cash counters
 - "2" and "H" = all counters
 - "3" and "H" = settings
 - "4" and "H" = popularity
 - "5" and "H" = hit parade of this location
 - "6" and "H" = last 20 error messages

Note: When a popularity counter has reached value 200, all popularity counters are divided by half of the amount. After dividing the popularity printed out is relative; the number of divisions appears in the printout: "RELATIVE 000" to "xxx".

If the printer does not start, "E0" appears in Display 3.